

HALIFAX

Since 1991

Halifax è un marchio storico, nato negli anni '90 nel cuore della Brianza, culla di sapienti artigiani e del manufatto artigianale, grazie alla straordinaria sapienza nell'arte della lavorazione del legno, alla selezione dei materiali migliori, ha realizzato e realizza ancora oggi un prodotto curato nel dettaglio e dalle pregiate finiture.

La nostra attenzione è sempre stata quella di trasformare la materia in un oggetto funzionale ma al contempo di design. Halifax nasce con prodotti realizzati in massello di legno dal sapore della memoria, ne sono l'esempio il tavolo Winston, la vetrina Vetriera, l'espositore Bacheca, che oggi, dopo 25 anni, riproponiamo con legni alternativi come "cultura del bello" e salvaguardia di soluzioni uniche e di grande personalità.

L'identificazione del made in Italy viene altresì distinta nello stile del contemporaneo, nella stravagante ricercatezza del prodotto d'autore, regalando ad ogni ambiente carattere e autenticità.

Halifax is a historic brand, born in the 90's at the heart of Brianza, cradle of master craftsmen, manufacturers of amazing hand-crafted works thanks to their skill in selecting the best materials and their advanced know-how in woodwork. Halifax always manufactured, during the years till nowadays, a highly refined product, extremely accurate in details and in the choice of the most precious finishes.

Our attention always focused on transforming the material into a functional object and a design object at the same time. Halifax initial collection offers a range of products manufactured in solid wood, with hints of memory, like the table Winston, the vitrine Vetriera and the showcase Bacheca. After 25 years we are re-proposing these items with alternative woods. Our heritage of beauty and unique solutions characterized by a strong personality.

The Made in Italy identifies with the style of Contemporaneo and with the inspired elegance of Collezione d'Autore, giving to each room character and authenticity.

LE MEMORIE

Ginevra	8
Isotta	10
Winston	12
Vassoia	14
Espositore console	16
Cassettaio	18
Bacheca	20
Vetriera	22



CONTEMPORANEO

Poltrone e Divani *Armchairs and sofas*

Bubble e pouff	28
Double	30
Kompasso	32
Point	34
Ambrogio	36
Blade	40
Cover	44
Lama	46

Sedie *Chairs*

Minni sedia	54
Minni sgabello	56
Teodolinda	58
Hosteria	62

Tavoli e Tavolini *Tables and Coffee Tables*

Ulisse	66
Vittorio fisso	68
Vittorio 300	70
Nodo	72
Hosteria	74
Carpenter	76
Mirto	78
Vittorio tavolino	80
Quadro	82
Naos	84
Art - Art Light	86
Swing	88



Contenitori e Librerie *Storage Units and Bookcases*

Lisboa	92
Half Lisboa	96
Extra	98
Achille	100
Square	102

Letti *Beds*

Ania	106
Karma	108
Thai	110
Taffy	114
Nikka	116
Japo	118
Quito	120

Comodini e Cassettiere *Night Tables and Chests of Drawers*

Aero	124
Taffy	126
Pyllon	130
Traccia	132

Specchi *Mirrors*

Imago	136
Tokyo	138
Venezia	140
Riflessi	142



COLLEZIONI D'AUTORE

Poltrone e Divani *Armchairs and sofas*

Serena	146
Feltrino	148
501	150
Intrecci poltrona	152
Intrecci divano	154
Intrecci collection 2-3-4 angolo	156
Luna di miele	158
Marilyn	160
Stealth	162
Boccaccio	164
Sartoriale	168

Sedie *Chairs*

Annette	176
---------	-----

Tavoli e Tavolini *Tables and Coffee Tables*

Righetta	180
Ivory - Black Swan Fisso	182
Ivory - Black Swan 300	184
Ivory - Black Swan tavolino	186
Intrecci 9.9	190



Contenitori e Librerie *Storage Units and Bookcases*

Taglia e cuci	194
Ivory	196
Network	198

Letti *Beds*

Le pieghe	202
Atelier	206

Comodini e Cassettiere *Night Tables and Chests of Drawers*

Le pieghe	210
-----------	-----

Specchi e Appendiabiti *Mirrors and Cloth-Hangers*

Pittura fresca	214
Macchia	216
Righetta Specchio	218
Cessato Specchio	219

OUTDOOR

Casper	222
Casper sofa	224
Casper chaise longue	226
Art Apple	227
Adamo&Eva	228
Nu•Ovo	230



**CONSERVANO, RICREANO
E RICOSTRUISCONO UN OGGETTO
CHE È STATO CAPACE DI PROGETTARE
IL FUTURO. IL TATTO E L'OLFATTO
PER RITORNARE ALLE RADICI
ALL'ORIGINALE IDENTITÀ.**

*MEMORIES PRESERVING, RECREATING AND
RECONSTRUCTING A PRIOR OBJECT, ABLE TO PLAN
THE FUTURE. THE SENSES OF SMELL AND TOUCH
TO GO BACK TO THE ROOTS OF THE ORIGINAL IDENTITY.*

LE MEMORIE

Ginevra	8
Isotta	10
Winston	12
Vassoia	14
Espositore console	16
Cassettaio	18
Bacheca	20
Vetriera	22

Ginevra

DESIGN ENRICO FRANZOLINI - ALESSANDRO GEDDA

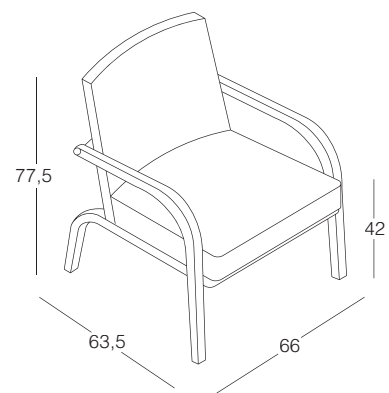

Poltrona con struttura in massello. Sedile e schienale imbottito e rivestito con tessuto sfoderabile.

Armchair with structure in solid wood. Seat and back padded and covered with removable fabric.



Isotta

DESIGN CRS HALIFAX - ALESSANDRO GEDDA

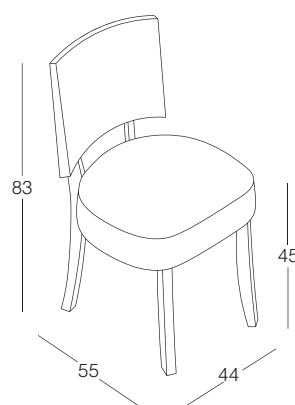

Sedia, struttura in massello, schienale in compensato curvato. Sedile imbottito e rivestito in tessuto sfoderabile. *Chair with structure in solid wood, back in curved multi-layer. Seat padded and covered with removable fabric.*



Winston

DESIGN MARIANNE DAY LEWIS - ALESSANDRO GEDDA

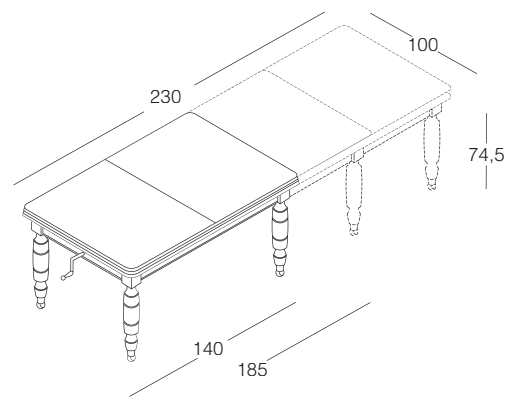

Tavolo in legno con piano allungabile in tre misure.
Gambe in massello tornito e ruote metallo finitura canna
di fucile.

Wooden table with extensible top in three sizes.
Legs in solid turned wood, metal wheels varnished Canna
di Fucile.



Vassoia

DESIGN CRS HALIFAX - ALESSANDRO GEDDA

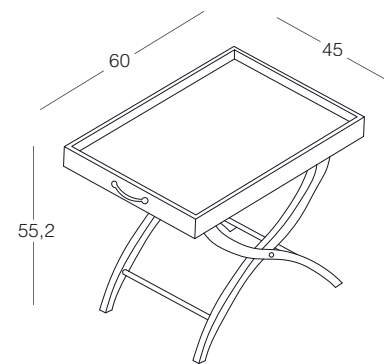

Tavolino multiuso con struttura in massello.
Vassoio asportabile.

*Multi-purpose coffee table with structure in solid wood.
Removable tray.*



Espositore Console

DESIGN ANTONIO CITTERIO - ALESSANDRO GEDDA

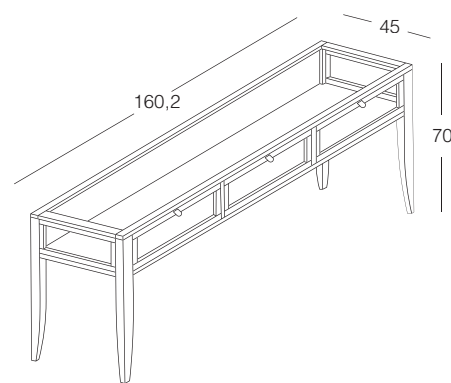

Console con struttura in massello e vetro temperato.
Aperture frontali a ribalta.

Console with structure in solid wood and tempered glass.
Front pull-down opening.



Cassettaio

DESIGN MARIANNE DAY LEWIS - ALESSANDRO GEDDA

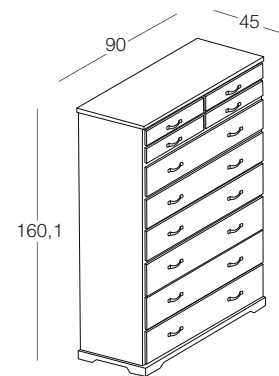

Cassetiera in legno con maniglie in metallo.

Wooden chest of drawers with metal handles.



Bacheca

DESIGN ANTONIO CITTERIO - ALESSANDRO GEDDA

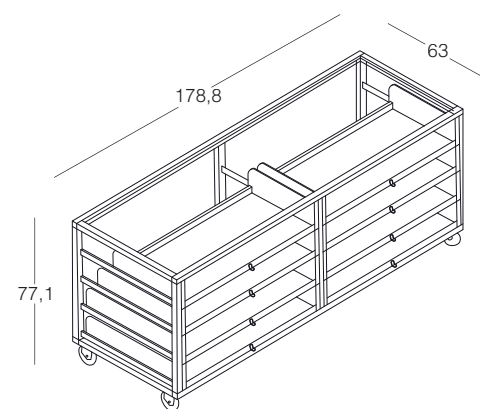

Contenitore vetrina dotato di ruote. Struttura in massello e vetro temperato.

Showcase on wheels. Structure in solid wood and tempered glass.



Vetriera

DESIGN MARIANNE DAY LEWIS - ALESSANDRO GEDDA

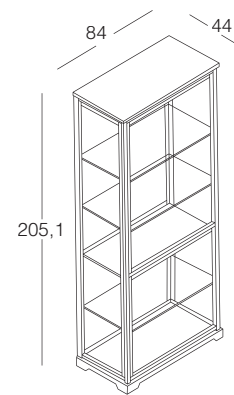

Contenitore vetrina con struttura in massello e vetro temperato. Aperture laterali.

Vitrine with structure in solid wood and tempered glass. Side opening.





**AMPIA E COMODA UNA POLTRONA DOVE
APPISOLARSI CON DOLCEZZA, IN SOLITARIA
O IN CONDIVISIONE QUANDO SI OFFRE
NELLA SUA FORMA ESTESA , ADORNATA
DI VESTI PREZIOSE.**

*AN AMPLE AND COMFORTABLE ARMCHAIR WHERE TO FALL
ASLEEP SOFTLY, ALONE OR SHARING WITH OTHERS IN THE
OPEN VERSION, ADORNED WITH PRECIOUS DRESSES.*

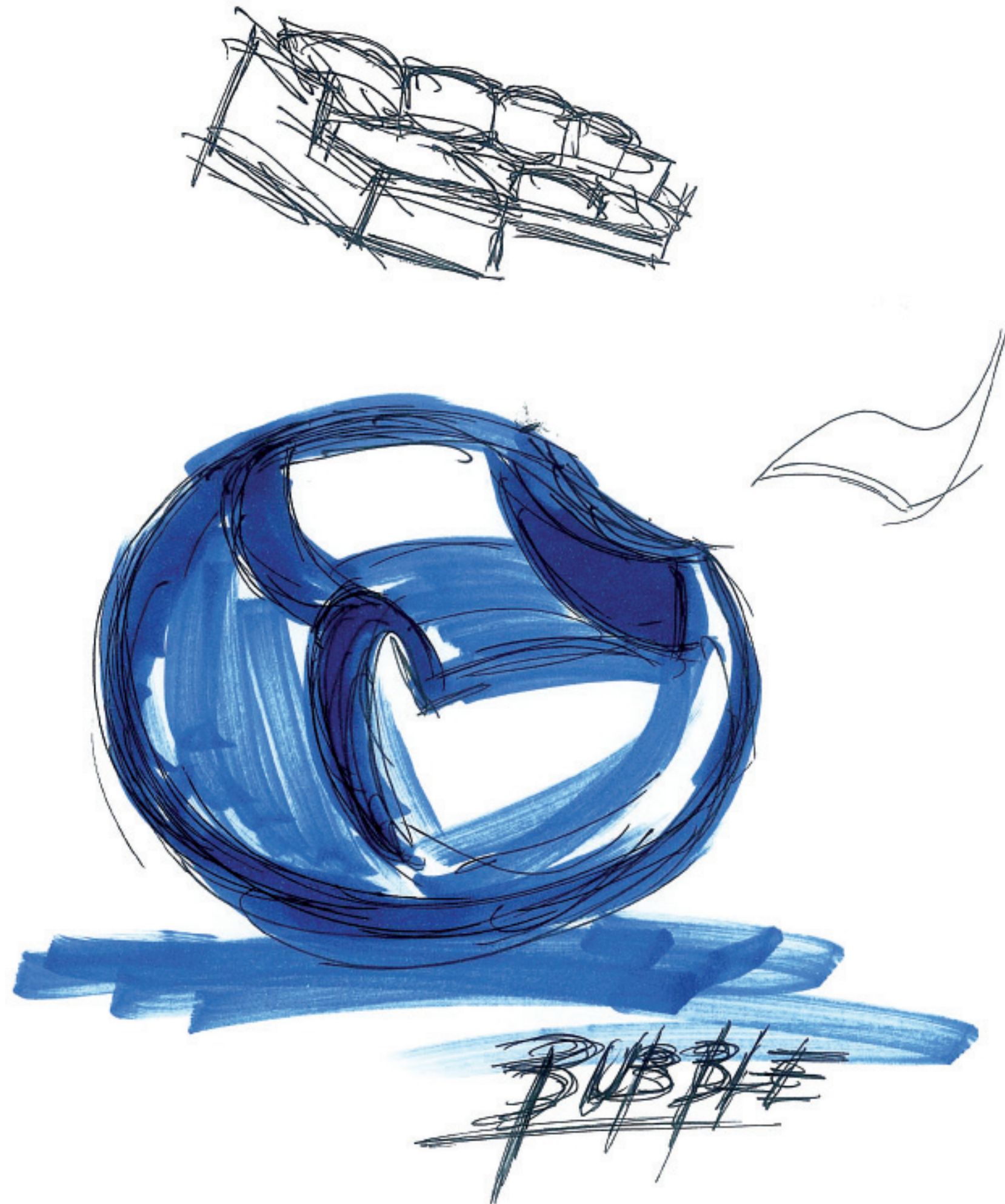

CONTEMPORANEO

Poltrone e Divani *Armchairs and Sofas*

Bubble e pouff	28
Double	30
Kompasso	32
Point	34
Ambrogio	36
Blade	40
Cover	44
Lama	46

Bubble e pouff

DESIGN MARCO BOGA

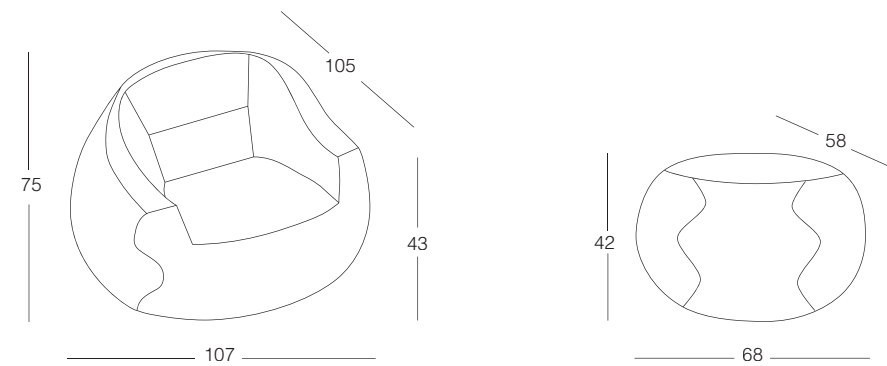

Poltrona con struttura in metallo annegato nel poliuretano con piastra girevole. Pouff in poliuretano espanso. Rivestimento in tessuto sfoderabile o in pelle fisso.

Armchair with metal structure embedded in polyurethane foam with swivel plate. Pouf in polyurethane foam. Removable fabric cover or non removable leather cover.



Double

DESIGN FABRIZIO ZAPPA

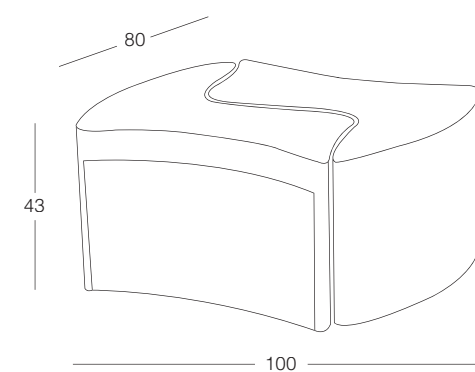

Pouff con fusto in legno e imbottiture in poliuretano espanso. Rivestimento in pelle fisso. Profili di appoggio in metallo tubolare finitura canna di fucile.

Pouf with wooden frame and polyurethane foam upholstery. Non removable leather cover. Metal support profiles finish canna di fucile.



Kompasso

DESIGN CRS HALIFAX

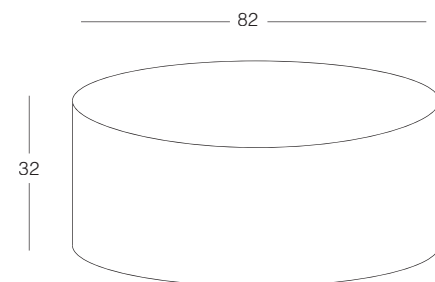
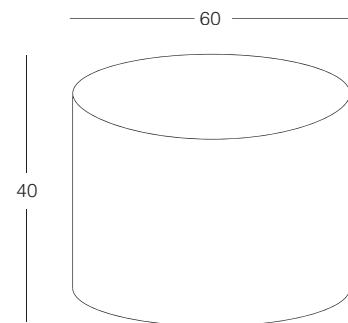

Pouff con fusto in legno e imbottitura in poliuretano a densità differenziata.
Rivestimento in tessuto sfoderabile o in pelle fisso.

*Pouf with wooden frame and different density polyurethane foam upholstery.
Removable fabric cover or non removable leather cover.*



Point

DESIGN PIVA ASSOCIATI

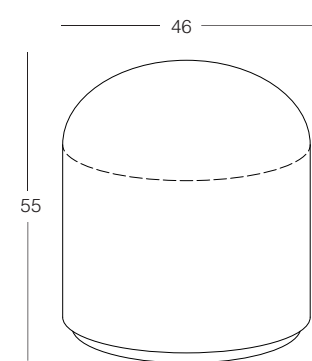
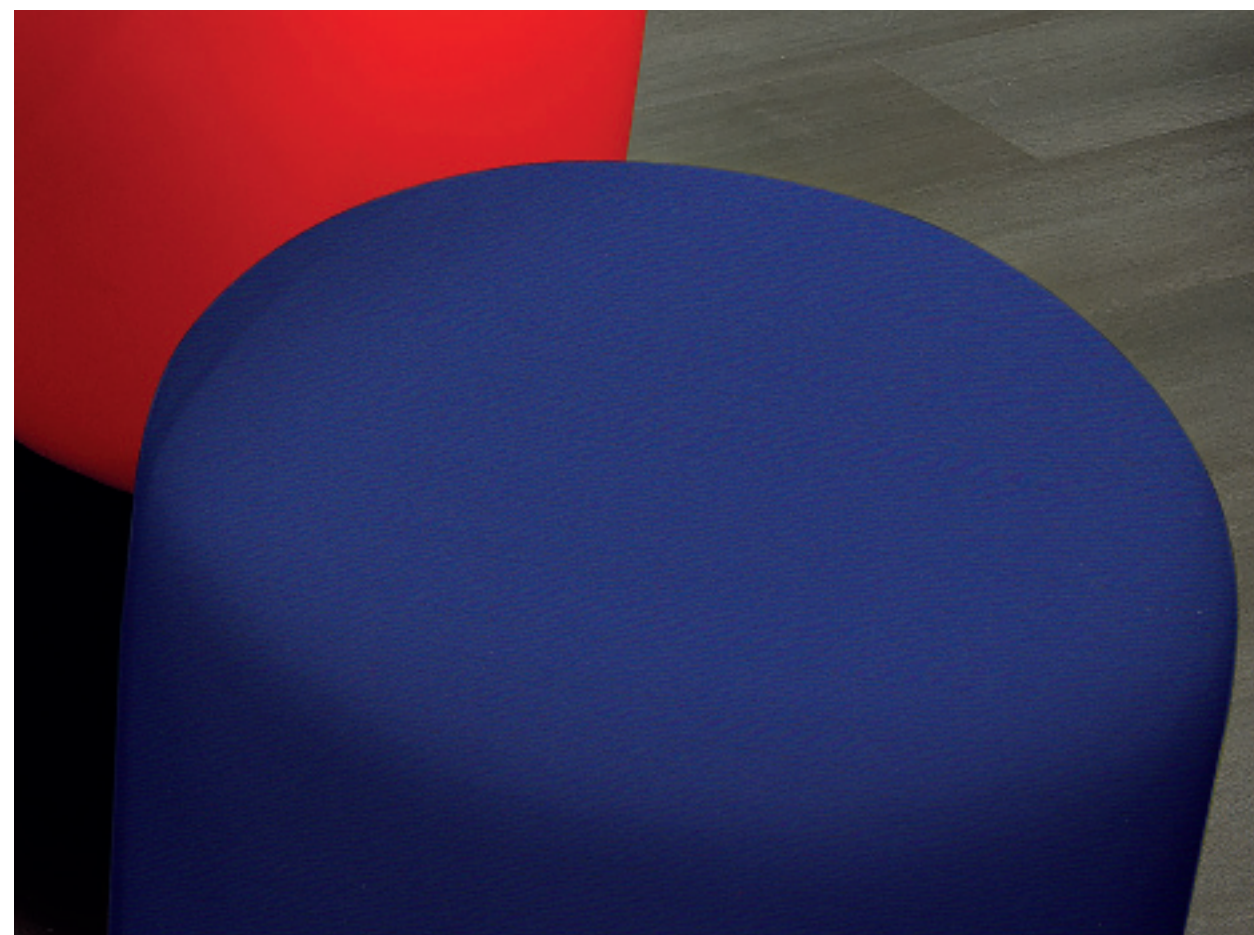

Pouff girevole con fusto in legno e imbottitura in poliuretano a densità differenziata.
Rivestimento in tessuto bi-elastico sfoderabile.

*Swivel pouf with wooden frame and different density polyurethane foam upholstery.
Removable stretch fabric cover.*



Ambrogio

DESIGN CRS HALIFAX



Divano componibile con struttura in legno rivestita in poliuretano a densità differenziata. Cuscino schienale in piuma con inserto in poliuretano. Rivestimento in tessuto sfoderabile o in pelle fisso.

Modular sofa with wooden frame covered with different density polyurethane foam. Backrest cushion in feather with polyurethane internal support. Removable fabric cover or non removable leather cover.





ALZARE
LENOTA

CANNA BI FUCUS
SABINATA

- per gli - camp di f
 " bump
 - Venne collezionat
 con tessuti fiorati
 CON CAVALLINO
 A
 V/XV



Blade

DESIGN DANIELE LO SCALZO MOSCHERI



Sistema di sedute con struttura in legno rivestito in poliuretano espanso a densità differenziata. Cuscini sedile e schienale in poliuretano espanso. Rivestimento in tessuto sfoderabile o in pelle fisso. Piedini e retroschienale in metallo finitura canna di fucile.

Seating system with wooden frame covered with different density polyurethane foam. Seat and back cushions in polyurethane foam. Removable fabric cover or non removable leather cover. Metal feet and back bar finish canna di fucile.



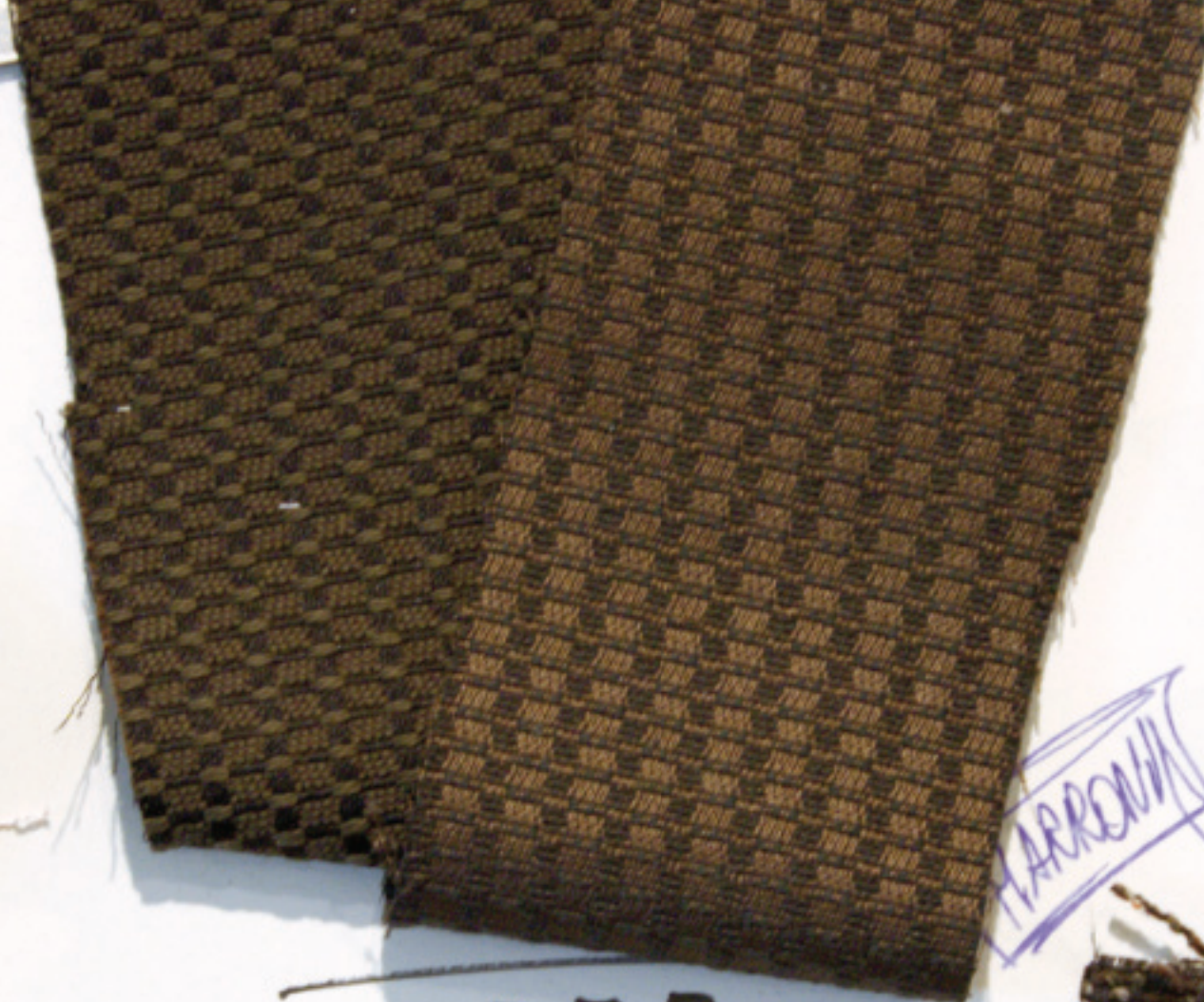

DDAD
DIPD

HARRON



PE



Handwritten scribbles in black ink, resembling a stylized pattern or signature.

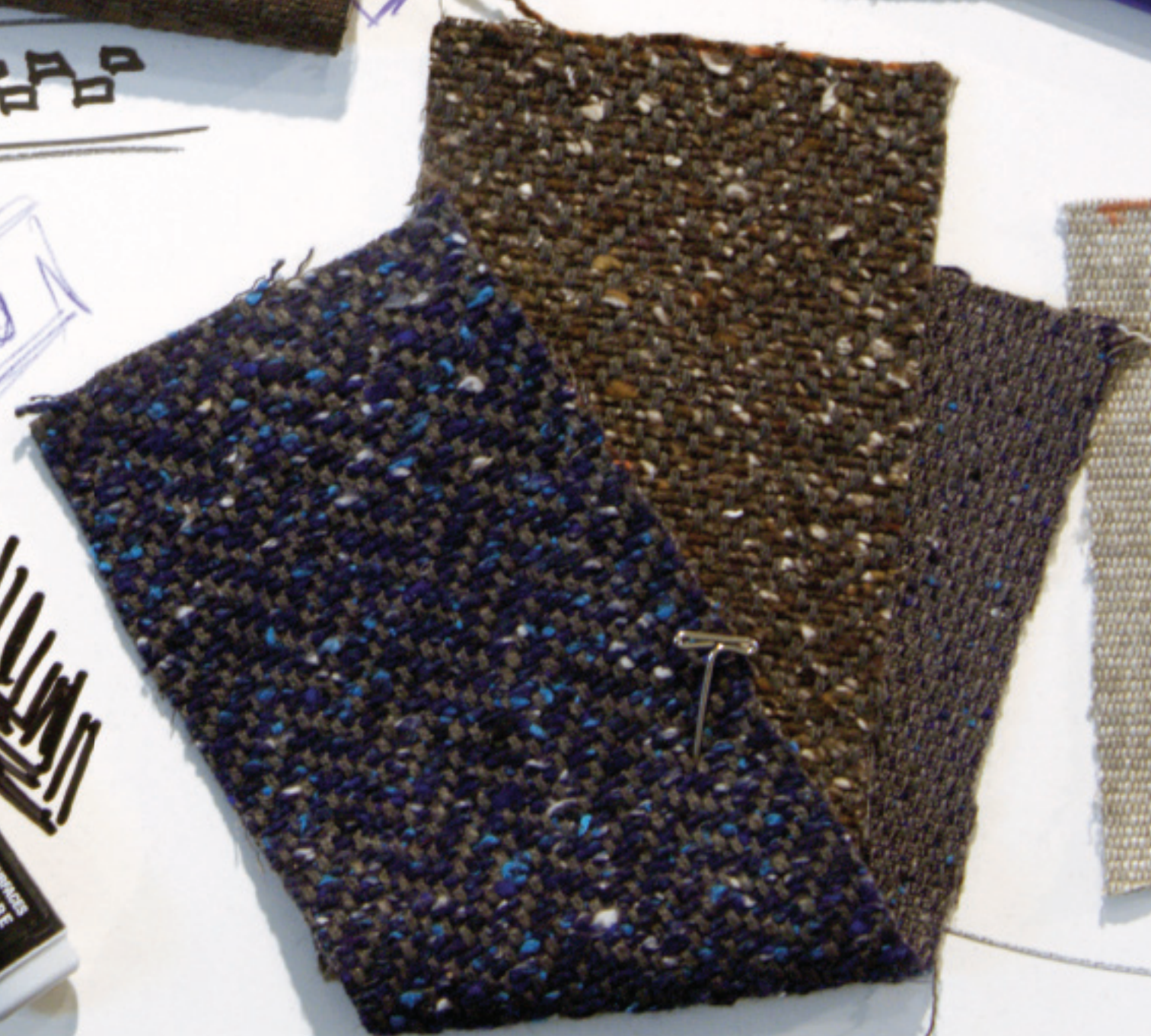

DIPD TRADITION



Cover

DESIGN CRS HALIFAX



Sistema di sedute con struttura in legno rivestito in poliuretano espanso. Cuscini sedile e schienale nella versione misto piuma.

Seating system with wooden frame covered with polyurethane foam. Seat and back cushions in mixed feathers.



Lama

DESIGN MAURO LIPPARINI



Sistema di sedute con base in acciaio. Schienale rialzato con supporti in acciaio e struttura in legno rivestita in poliuretano. Comprende un cuscino schienale in misto piuma ed un poggiatesta removibile in poliuretano. Rivestimento in tessuto sfoderabile o in pelle fisso.

Seating system supported by a steel base frame. Raised back with steel supports and wooden frame covered with polyurethane. A mixed feather back cushion and a removable headrest in polyurethane are included. Removable fabric cover or non removable leather cover.



Ambrogio

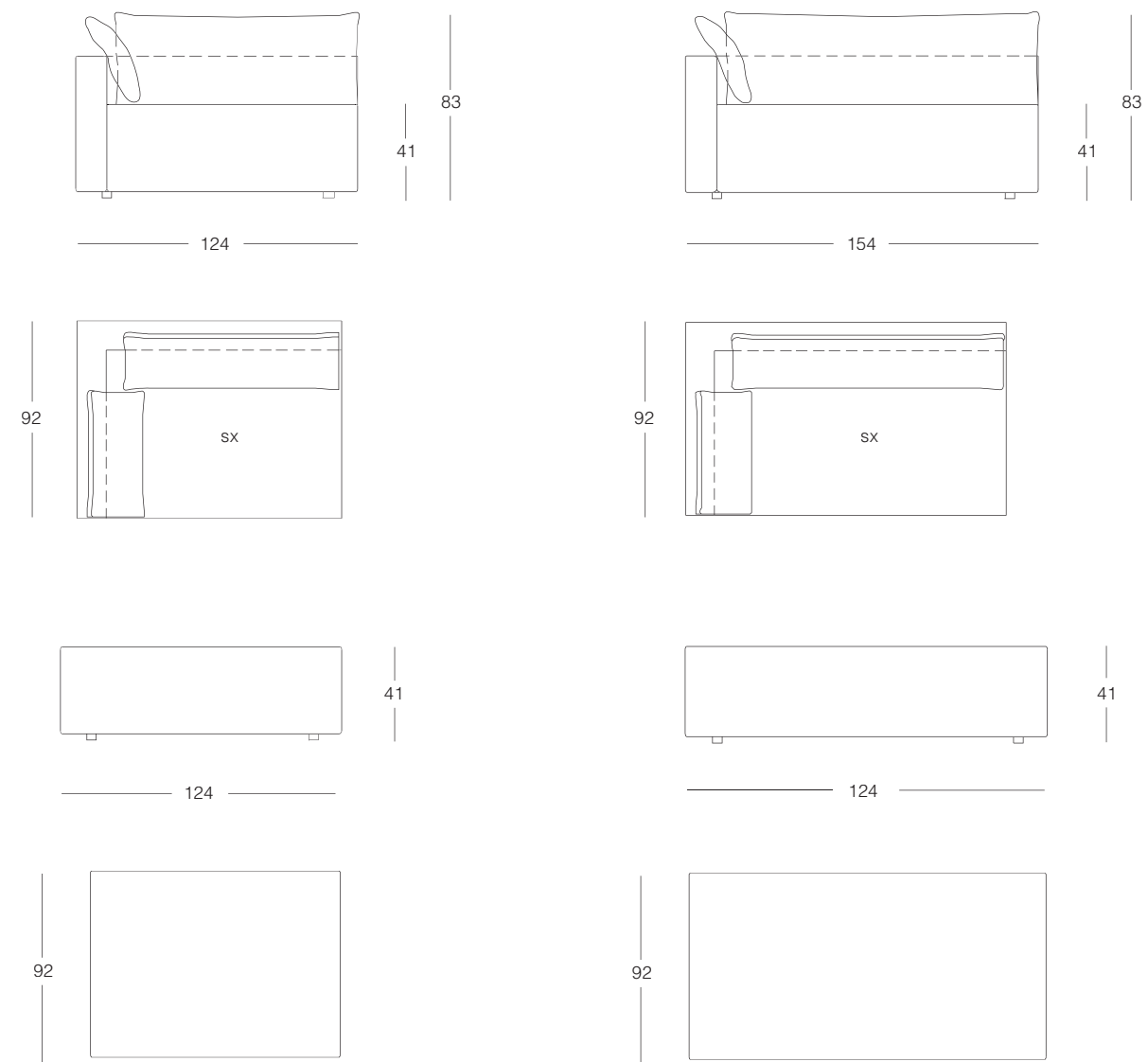

Blade

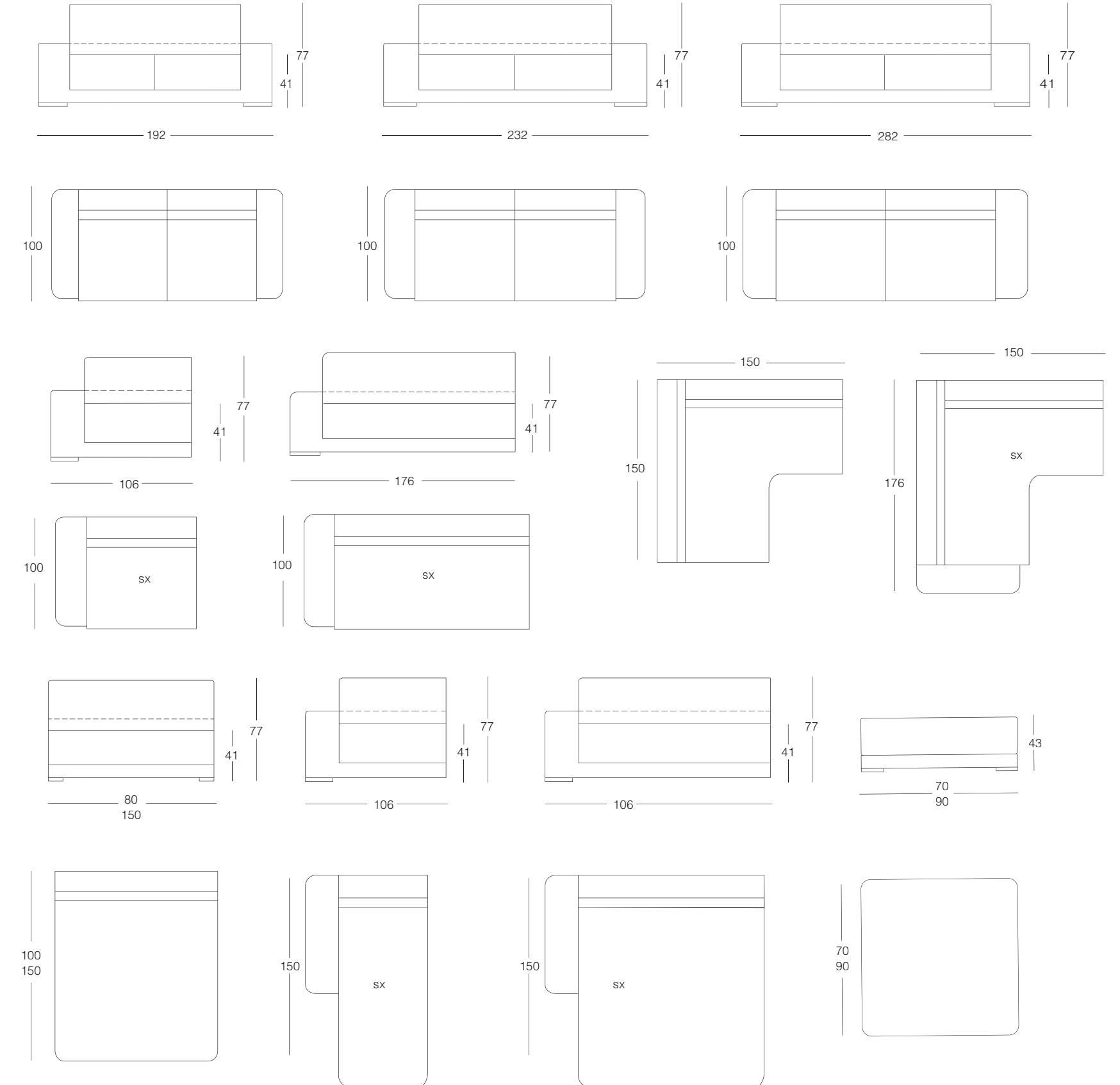

Cover



Lama

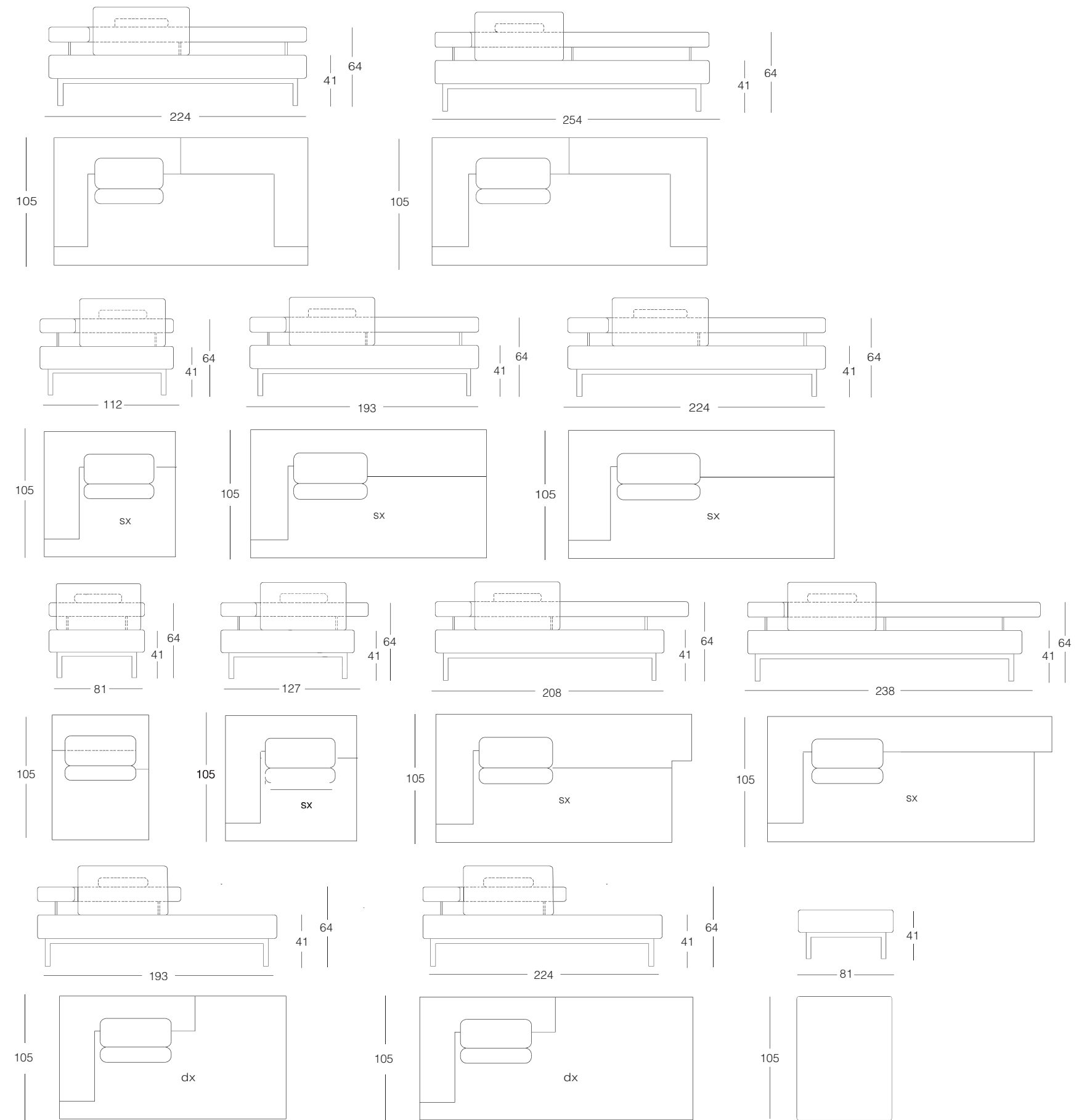



**LEGNO, LANE E TESSUTI, METALLI E CUOIO
DANNO FORMA ALLE SEDUTE OGGETTI
D'ARREDO CHE COMPLETANO CON TIPICITÀ
LA ZONA GIORNO.**

*WOOD, WOOL AND FABRICS, METALS AND LEATHERS
GIVE SHAPE TO THE SEATINGS, REAL FURNITURE OBJECTS
COMPLETING THE LIVING AREA WITH TYPICALITY.*

CONTEMPORANEO

Sedie *Chairs*

Minni sedia	54
Minni sgabello	56
Teodolinda	58
Hosteria	62

Minni sedia

DESIGN ANTONIO CITTERIO

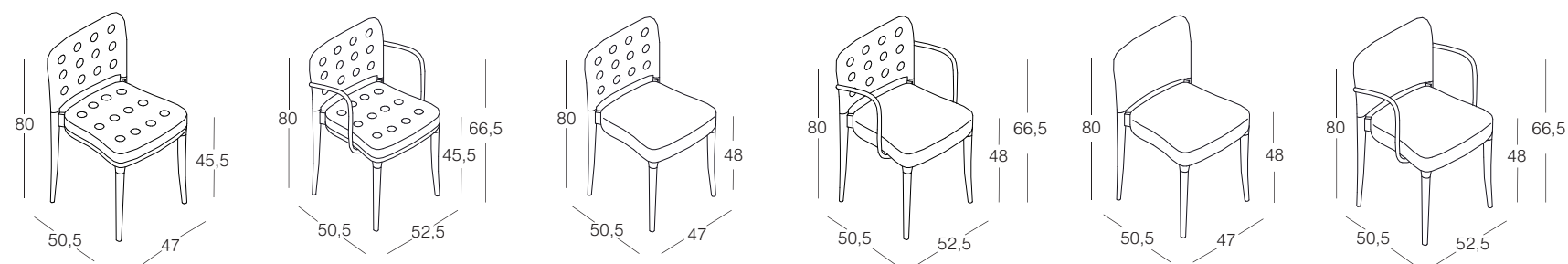

Sedia impilabile con gambe e braccioli in alluminio naturale. Sedile in materiale plastico o imbottito e rivestito con tessuto sfoderabile. Schienale in materiale plastico o foderato.

Stackable chair with natural aluminium legs and armrests. Seat in plastic material or foamed and covered with removable fabric.



Minni sgabello

DESIGN ANTONIO CITTERIO

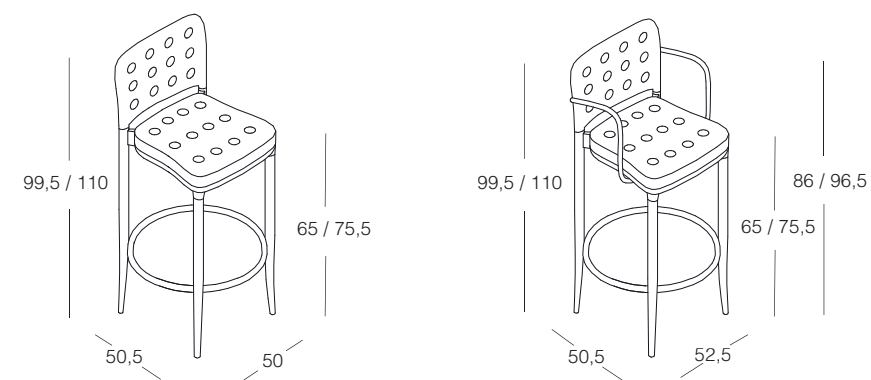

Sgabello con gambe e braccioli in alluminio naturale.
Sedile e schienale in materiale plastico.

*Stool with natural aluminium legs and armrests.
Seat and back in plastic material.*



Teodolinda

DESIGN CRS HALIFAX

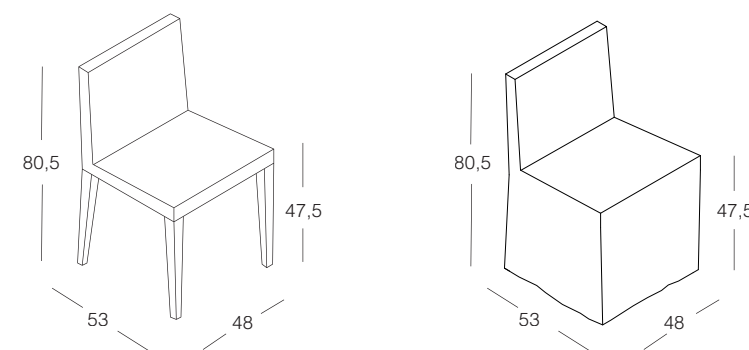

Sedia con struttura in profilato d'acciaio annegato nel poliuretano. Rivestimento in tessuto sfoderabile o in pelle fisso. Teodolinda con balza. Rivestimento in tessuto sfoderabile.

Chair with steel structure embedded in polyurethane foam. Removable fabric cover or non removable leather cover. Teodolinda with flounce. Removable fabric cover.





Hosteria

DESIGN ALESSANDRO GEDDA

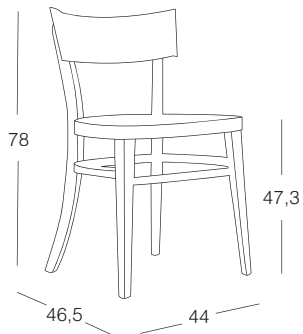

Sedia in legno laccato colore.

Wooden chair with colour lacquer finish.



FUNZIONALE ED ESSENZIALE, SPOGLIO O IMBANDITO SPAZIOSO O RIDOTTO, SIMBOLO DI CONDIVISIONE E CONVIVIALITA'.

*FUNCTIONAL AND ESSENTIAL, PLAIN OR DRESSED,
AMPLE OR SMALL, A SYMBOL OF SHARING AND CONVIVIALITY.*

CONTEMPORANEO

Tavoli e Tavolini

Tables and Coffee Tables

Ulisse	66
Vittorio fisso	68
Vittorio 300	70
Nodo	72
Hosteria	74
Carpenter	76
Mirto	78
Vittorio tavolino	80
Quadro	82
Naos	84
Art - Art Light	86
Swing	88

Ulisse

DESIGN CRS HALIFAX

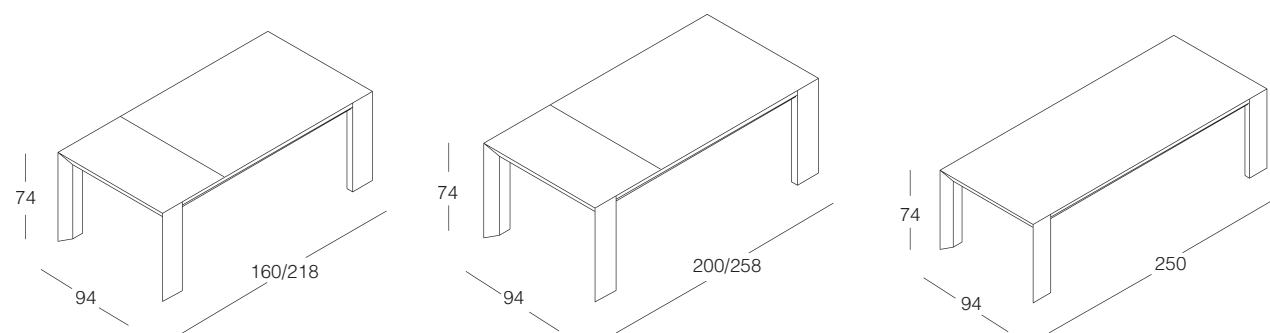

Tavolo rettangolare allungabile o fisso con piano e gambe in legno. *Rectangular extensible or fixed table with wooden top and wooden legs.*



Vittorio fisso

DESIGN LA MENSA

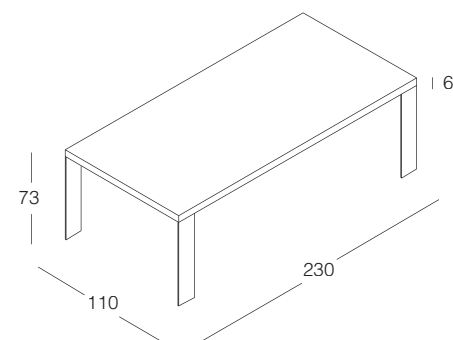
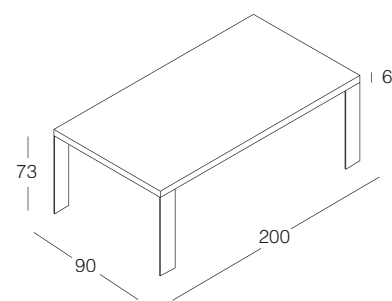

Tavolo rettangolare con piano in legno di forte spessore e gambe in metallo finitura canna di fucile.

Rectangular table with a thick wooden top and metal legs finish canna di fucile.



Vittorio 300

DESIGN LA MENSA

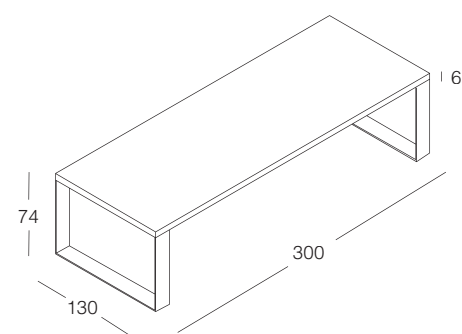

Tavolo rettangolare con piano in legno di forte spessore e gambe in metallo finitura canna di fucile.

Rectangular table with a thick wooden top and metal legs finish canna di fucile.



Nodo

DESIGN CARLO BARTOLI

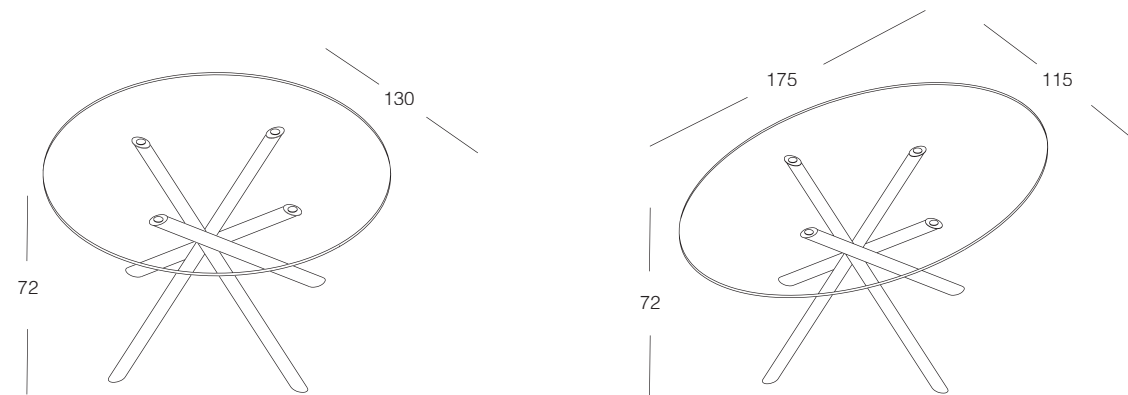

Tavolo ovale o rotondo con piano in cristallo e gambe in acciaio cromato lucido o finitura canna di fucile.

Oval or round table with top in glass and legs in stainless steel finish glossy chromed or canna di fucile.



Hosteria

DESIGN ALESSANDRO GEDDA

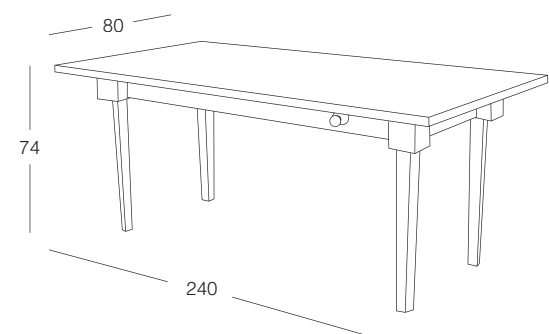

Tavolo con struttura in legno laccato colore. Piano in marmo o legno laccato colore.

Table with structure in colour lacquered wood. Top in marble or colour lacquered wood.



Carpenter

DESIGN CRS HALIFAX

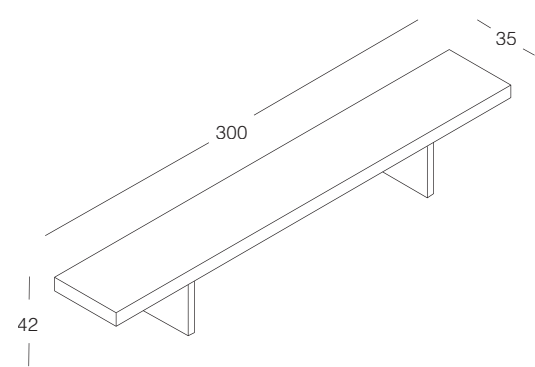
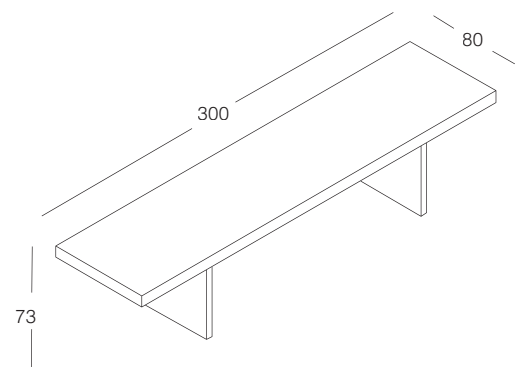

Tavolo e panca in massello di teak naturale, finitura grezza.

Table and bench in solid teak wood, raw finish.



Mirto

DESIGN MIRTO ZOCCA

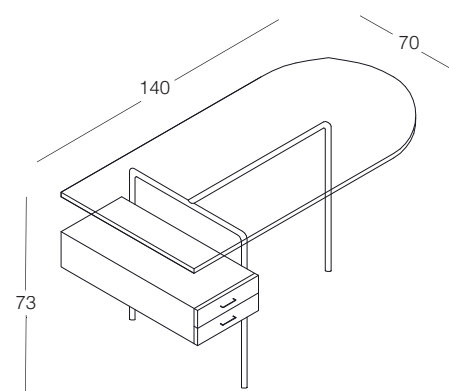

Scrivania con piano in vetro trasparente temperato, struttura in metallo cromato o finitura canna di fucile e cassettera in legno.

Desk with top in transparent tempered glass, metal structure finish chromed or canna di fucile and wooden drawer unit.



Vittorio tavolino

DESIGN LA MENSA

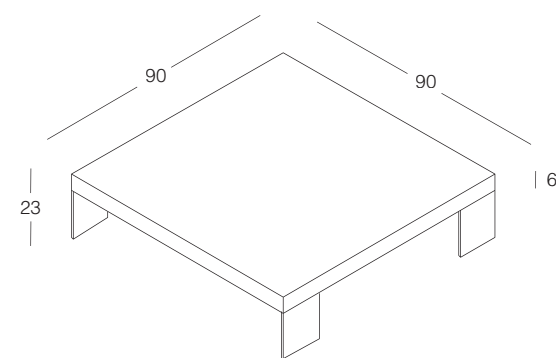

Tavolo basso con piano in legno e gambe in metallo
finitura canna di fucile.

*Coffee table with wooden top and metal feet finish canna
di fucile.*

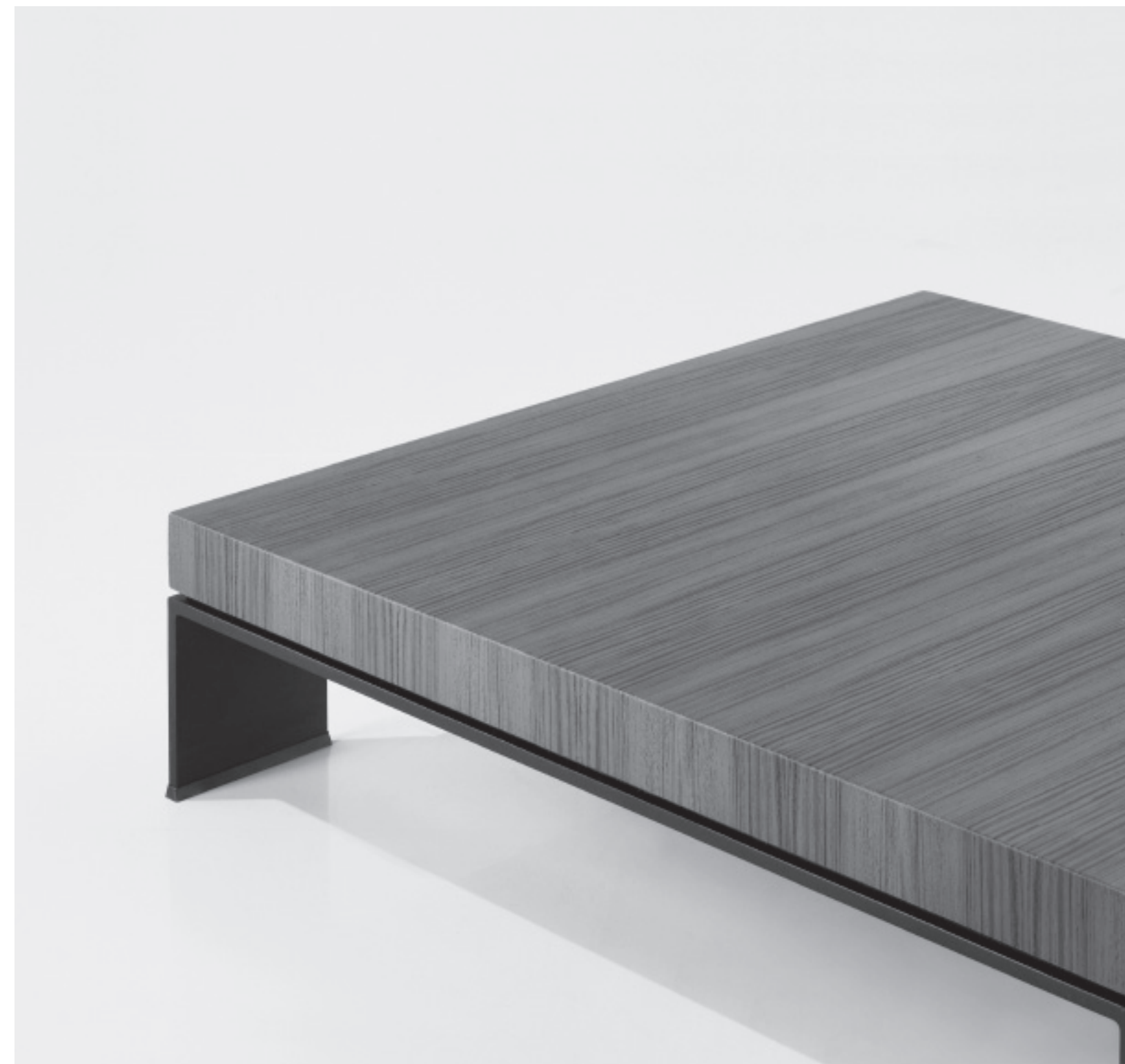

Quadro

DESIGN CRS HALIFAX

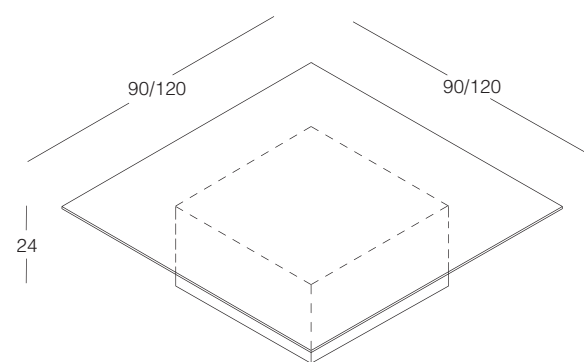

Tavolo basso completamente in metallo finitura canna di fucile. *Coffee table entirely in metal finish canna di fucile.*



Naos

DESIGN CRS HALIFAX

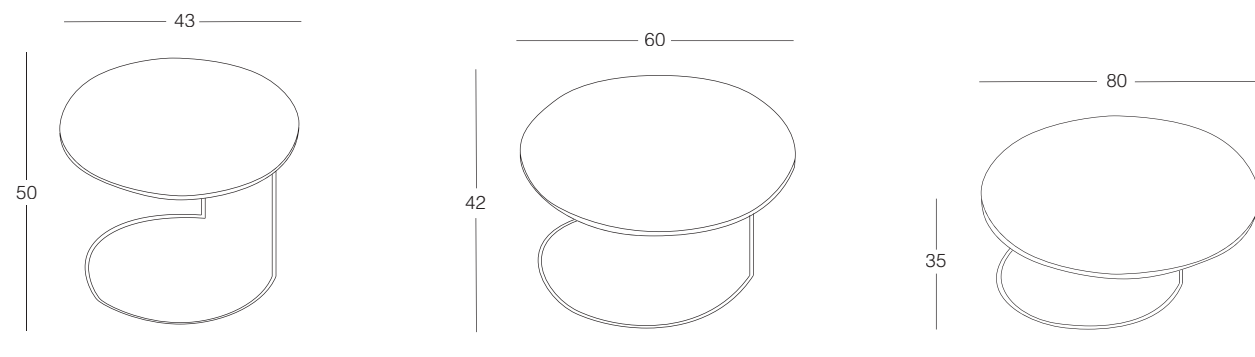

Serie di tavolini con struttura in metallo finitura canna di fucile e piano d'appoggio laccato.

Range of coffee tables with metal structure finish canna di fucile and lacquered top.



Art - Art Light

DESIGN CRS HALIFAX

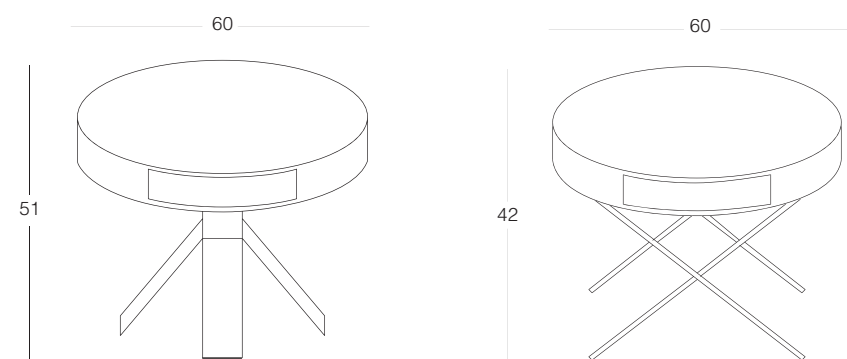

Tavolini con basi in metallo finitura canna di fucile e piano con cassetto in legno laccato.

Coffee tables with metal bases finish canna di fucile and top with drawer in lacquered wood.

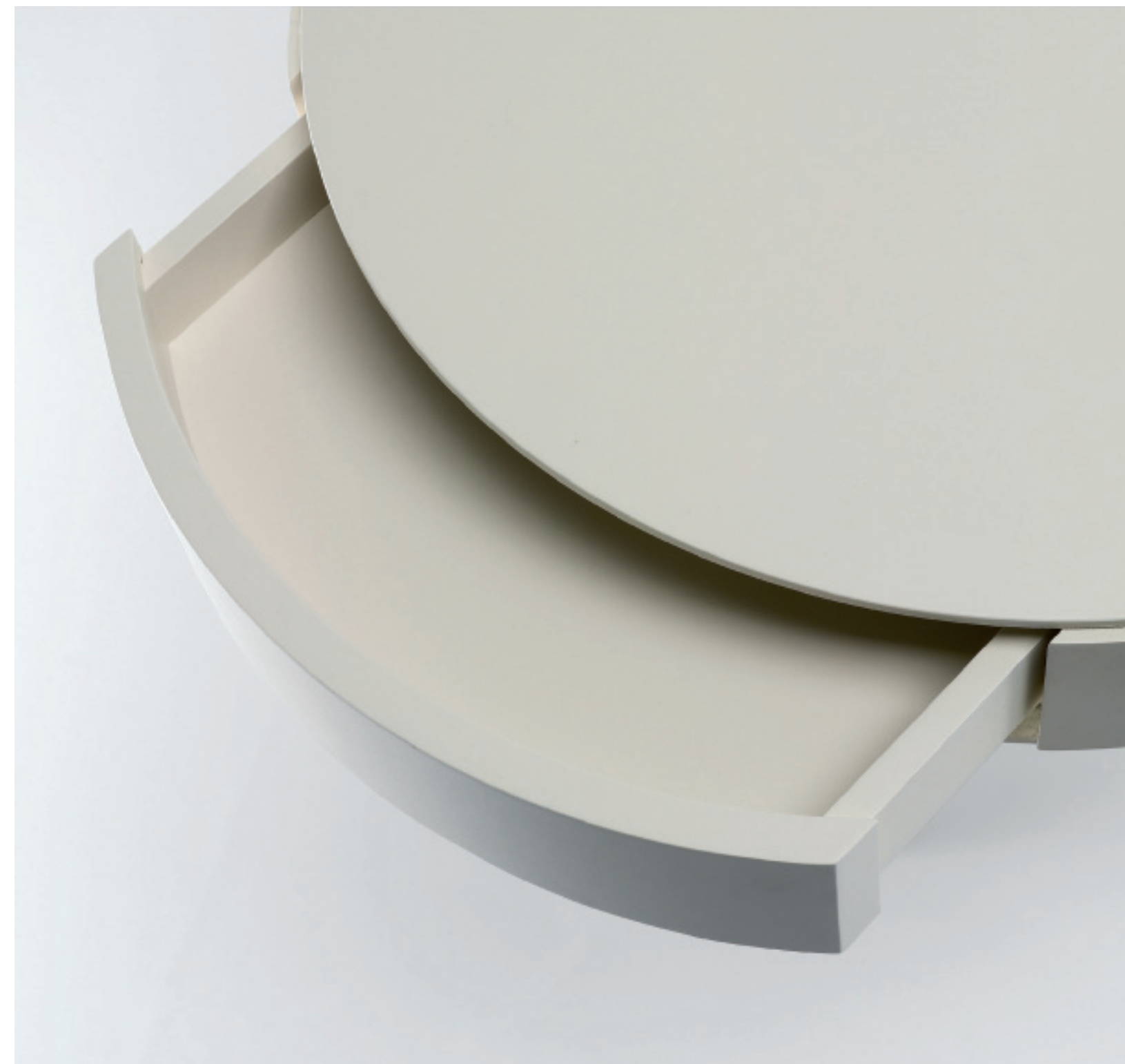

Swing

DESIGN CRS HALIFAX

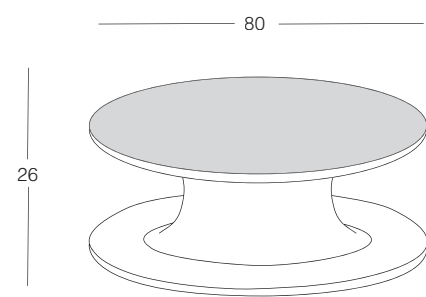

Tavolini con struttura in poliuretano espanso laccato e top in vetro verniciato.

Coffee table with structure in lacquered polyurethane foam and top in lacquered glass.



**ELEMENTI D'ARREDO INTRAMONTABILI,
MADIE E CONTENITORI, ASSOCIATI AD UN
DESIGN SEMPLICE ED ELEGANTE . LIBRERIE
COME SCULTURE CHE CON I MATERIALI
E LE FORME DIVENTANO PEZZI UNICI.**

*TIMELESS FURNITURE PIECES, SIDEBOARDS AND STORAGE
ELEMENTS SHOWING A PLAIN AND ELEGANT DESIGN.
BOOKCASES LIKE SCULPTURES TRANSFORMING MATERIALS
AND SHAPES INTO UNIQUE PIECES.*

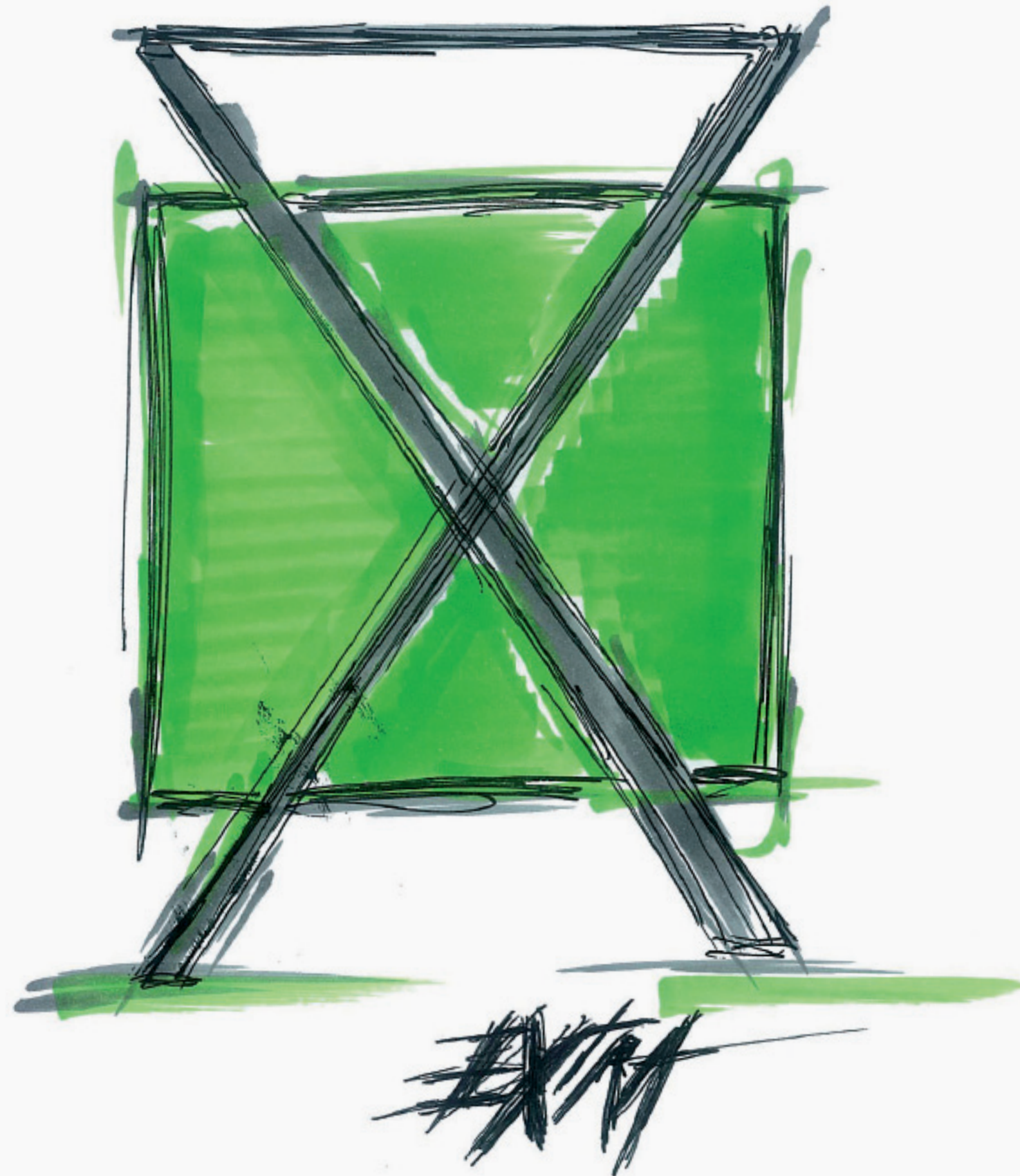

CONTEMPORANEO

Contenitori e Librerie *Storage Units and Bookcases*

Lisboa	92
Half Lisboa	96
Extra	98
Achille	100
Square	102

Lisboa

DESIGN ENRICO FRANZOLINI

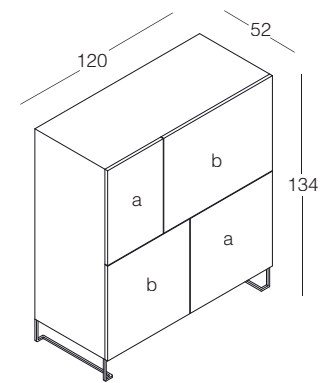

Contenitore in legno a quattro ante. Piedini in metallo finitura canna di fucile.

Wooden storage unit with four doors. Metal feet finish canna di fucile.





Galerie Sian

Keizersgracht 267
Amsterdam

Half Lisboa

DESIGN ENRICO FRANZOLINI

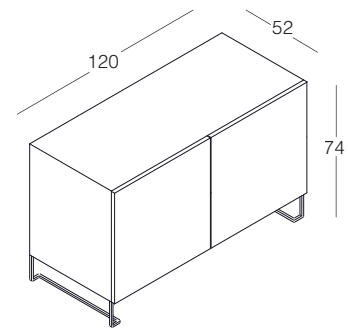

Contenitore in legno a due ante. Piedini in metallo
finitura canna di fucile.

Wooden storage unit with two doors. Metal feet finish
canna di fucile.



Extra

DESIGN RICCARDO ARBIZZONI

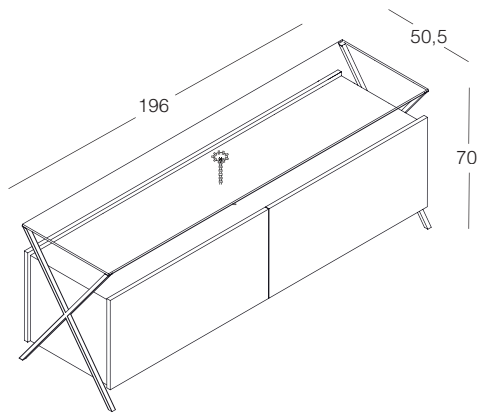

Contenitore in legno a due cassetti esterni e due vassoi interni, piano superiore in vetro trasparente temperato con struttura in acciaio e finitura canna di fucile.

Wooden storage unit with two drawers and two internal extractable trays. Top in transparent tempered glass. Structure in stainless steel finish canna di fucile.



Achille

DESIGN VITTORIO PRATO

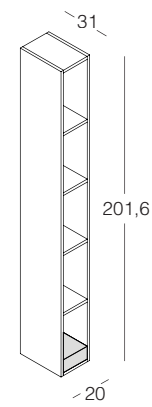

Contenitore libreria in legno e laccato, con pietra stabilizzante alla base in marmo Marquina. *Bookcase unit in wood or lacquer finish, with stabilizing stone at the base in marble Marquina.*



Square

DESIGN GIUSEPPE VIGANÒ

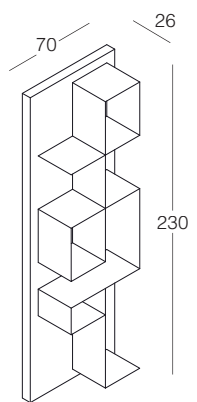

Libreria posizionabile in senso orizzontale o verticale.
Ripiani in lamiera piegata e verniciata, pannello in
essenza o laccato.

*Bookcase unit to be horizontally or vertically positioned.
Shelves in folded and varnished metal sheet. Back panel
in wood or lacquer finish.*



**MATERIALI RAFFINATI, VELLUTI E PELLI,
ARMONICHE ALTERNANZE DI VOLUMI, DI VUOTI
E PIENI VESTONO LA NOTTE DEI SOGNI.**

*REFINED MATERIALS, VELVET AND LEATHERS, A HARMONIOUS
SEQUENCE OF VOLUMES, OF EMPTY AND FULL, DRESSING UP
THE NIGHT OF DREAMS.*

CONTEMPORANEO

Letti *Beds*

Ania	106
Karma	108
Thai	110
Taffy	114
Nikka	116
Japo	118
Quito	120

Ania

DESIGN CRS HALIFAX

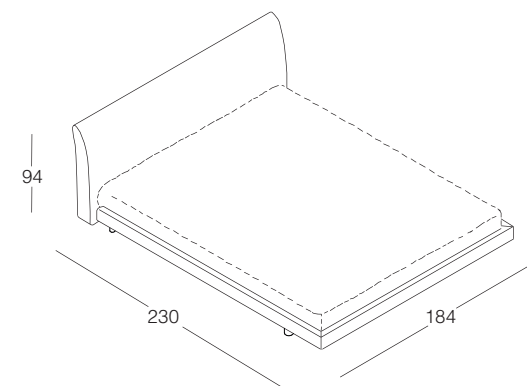
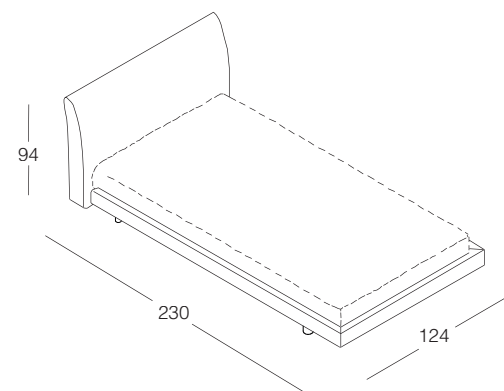

Letto con testata e base imbottite e rivestite con tessuto sfoderabile o in pelle fisso.

Upholstered headboard and base padded and covered with removable fabric or non removable leather.



Karma

DESIGN CRS HALIFAX

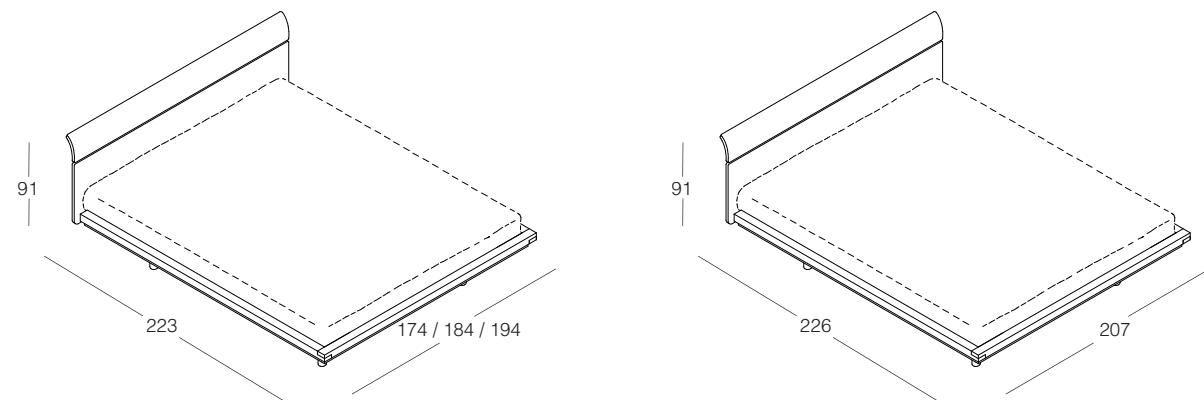

Letto con testata in multistrato curvato visibile ai bordi e base quadra in massello rivestito.

Bed with headboard made of curved plywood, edges at sight, and square base in veneered solid wood.



Thai

DESIGN CRS HALIFAX

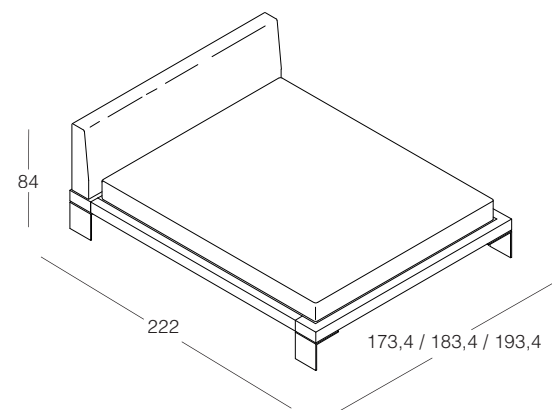

Letto con fascia in legno o rivestita in tessuto sfoderabile o in pelle fisso. Testata rivestita in tessuto sfoderabile o in pelle fisso. Piedi in metallo finitura canna di fucile.

Bed with base frame in wood or covered with removable fabric or non removable leather. Headboard covered with removable fabric or non removable leather. Metal feet finish canna di fucile.





Taffy

DESIGN ENNIO AROSIO

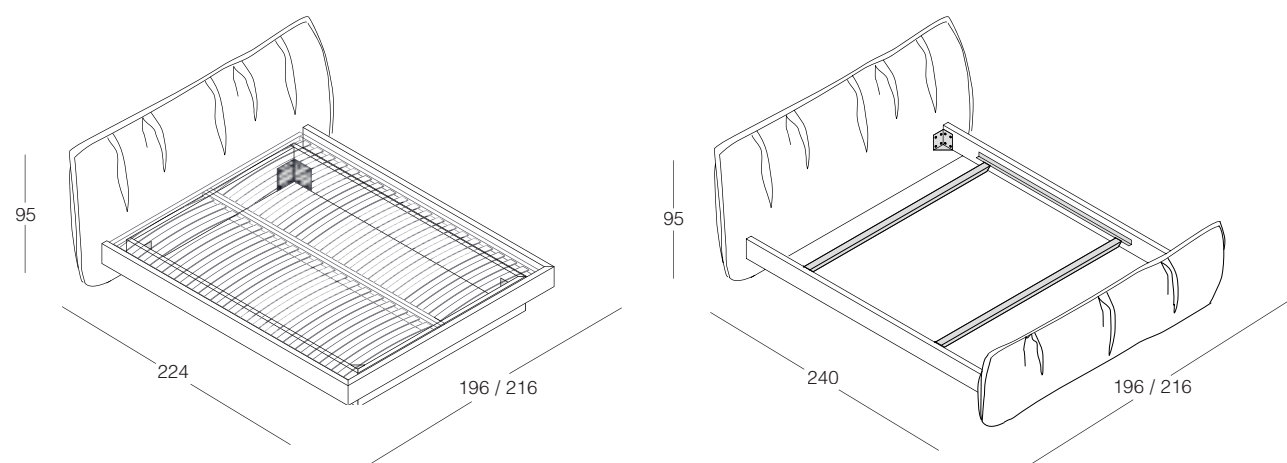

Letto con testata imbottita disponibile in due versioni: con pediera imbottita o con contenitore. Rivestimento in tessuto sfoderabile.

Bed with upholstered headboard available in two versions: with upholstered footboard or with storage. Removable fabric cover.



Nikka

DESIGN MARCO BOGA

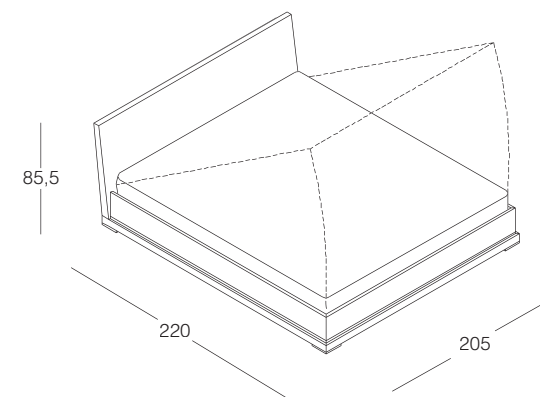
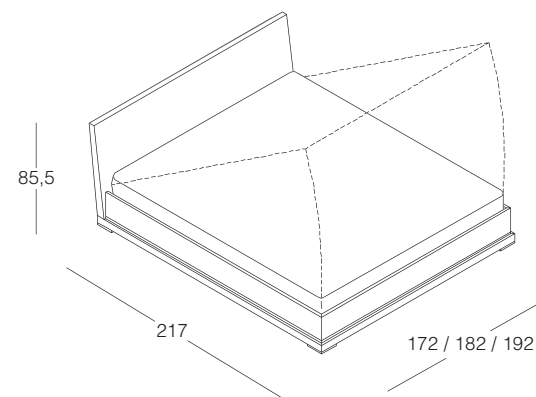

Letto con contenitore, testata legno e base imbottita rivestita con tessuto o pelle sfoderabili.

Storage bed with wooden headboard and upholstered base, covered with removable fabric or leather.



Japo

DESIGN CRS HALIFAX

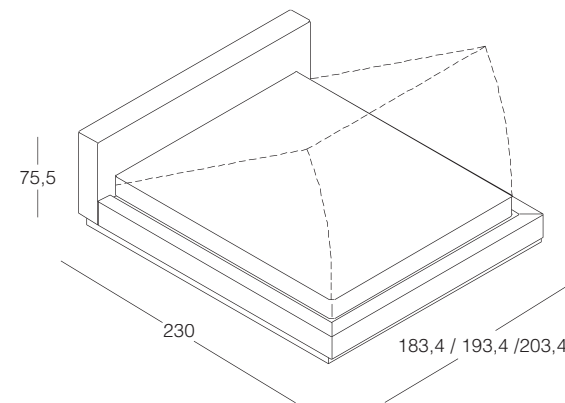

Letto con contenitore, con testata e base imbottite.
Rivestimento in tessuto sfoderabile o in pelle fisso.

*Storage bed with upholstered headboard and base.
Removable fabric cover or non removable leather cover.*



Quito

DESIGN CRS HALIFAX

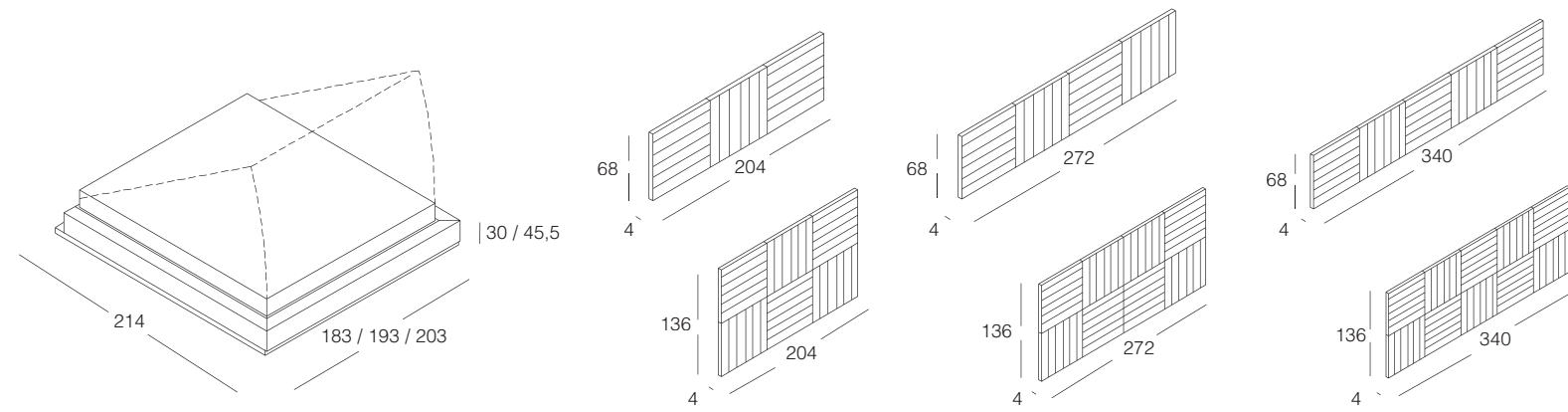

Letto con contenitore, con testata a pannelli in legno e base imbottita. Rivestimento in tessuto sfoderabile o in pelle fisso.

Storage bed with wooden panels headboard and upholstered base. Removable fabric cover or non removable leather cover.



**CASSETTIERA DI ALTEZZA CONTENUTA,
DAI LARGHI CASSETTI, CONTIENE
OGGETTI DIVERSI E, QUANDO SI AVVICINA
AL FIANCO DEL LETTO, DIVENTA COMODINO.
LINEE SOBRIE CHE SI VESTONO SEMPRE
DI NUOVI COLORI.**

*CHEST OF DRAWERS WITH LARGE DRAWERS TO CONTAIN
DIFFERENT OBJECTS. AT THE SIDE OF THE BED IT BECOMES
A NIGHT TABLE. PLAIN LINES ALWAYS WEARING NEW COLORS.*

CONTEMPORANEO

Comodini e Cassettiere

Night Tables and Chest of Drawers

Aero	124
Taffy	126
Pyllon	130
Traccia	132

Aero

DESIGN CRS HALIFAX

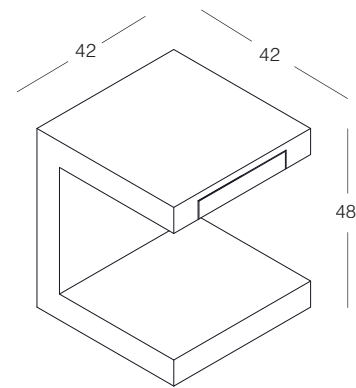
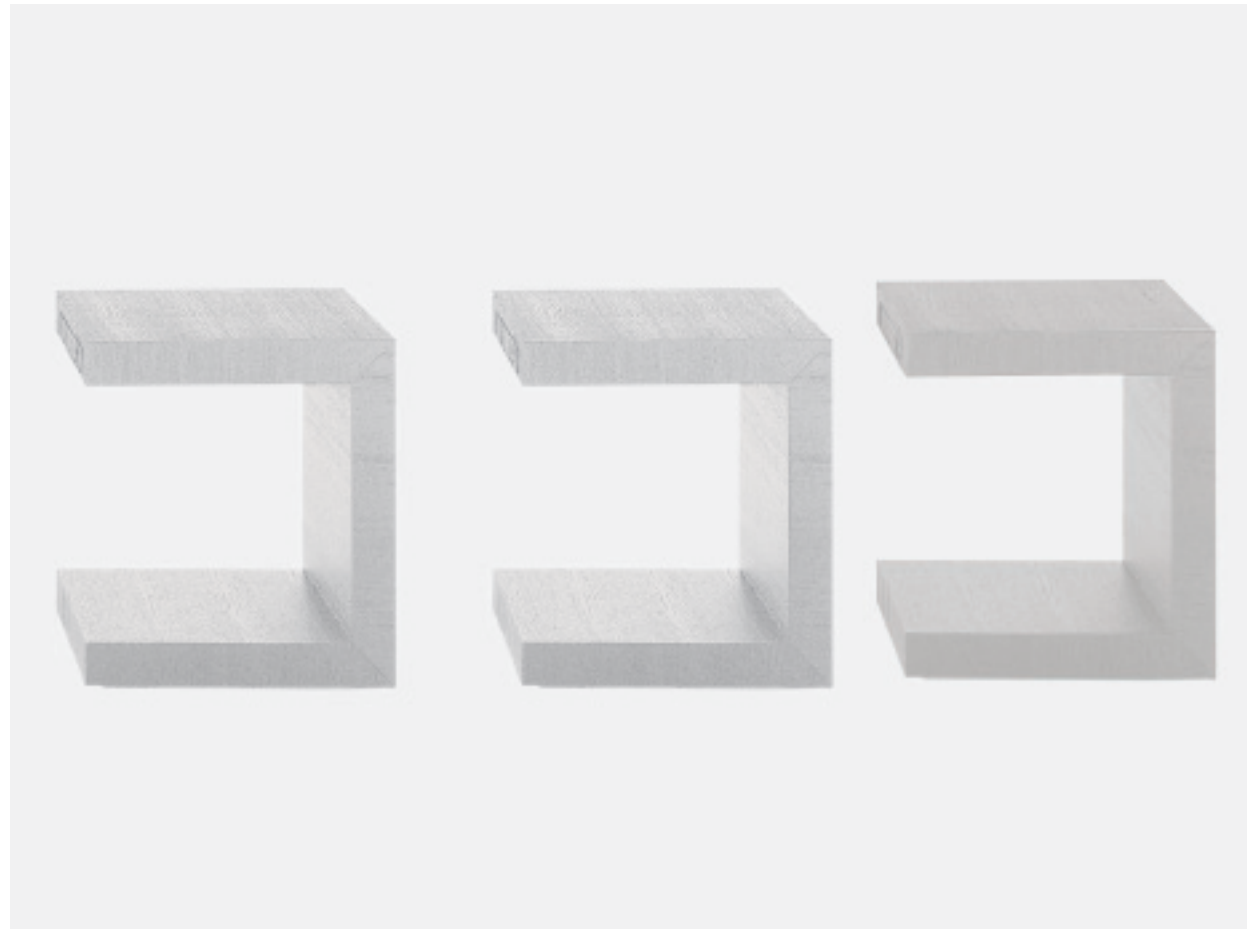

Comodino completamente in legno con cassetto inserito nel piano superiore.

Night table fully constructed in veneered wood with drawer integrated in the upper top.



Taffy

DESIGN ENNIO AROSIO

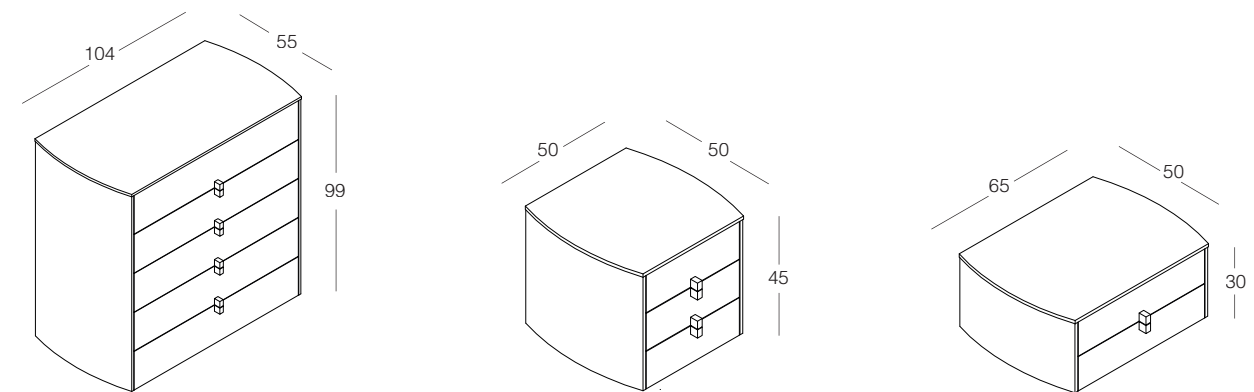

Serie contenitori in legno con fianchi sagomati, pomoli in metallo finitura canna di fucile.

Set of drawer elements in wood with rounded sides and metal handles finish canna di fucile.





Pyllon

DESIGN ENNIO AROSIO

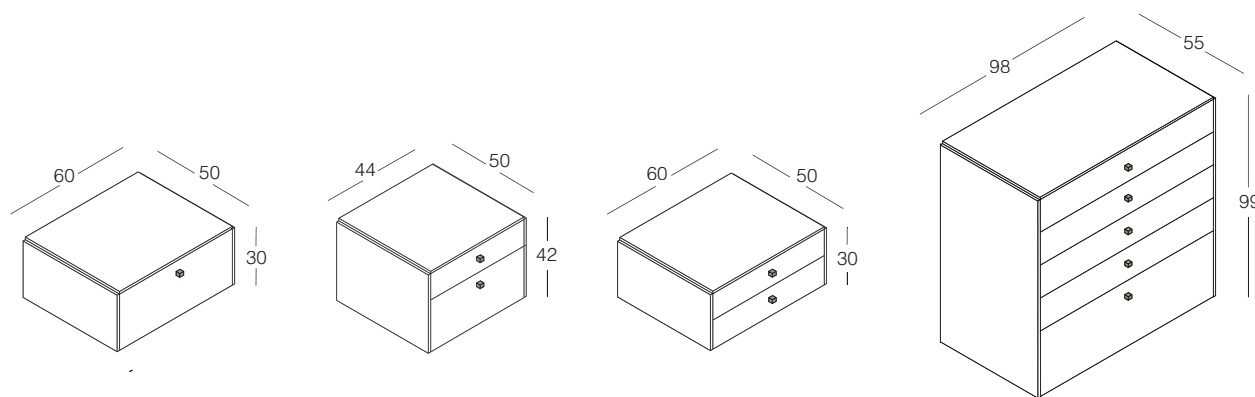

Serie contenitori in legno con pomoli in metallo finitura cannadi fucile. *Set of drawer elements in wood with metal handles finish canna di fucile.*



Traccia

DESIGN CRS HALIFAX

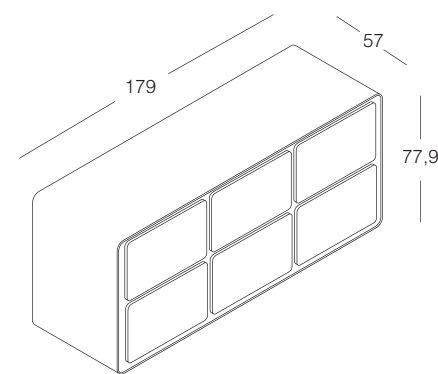
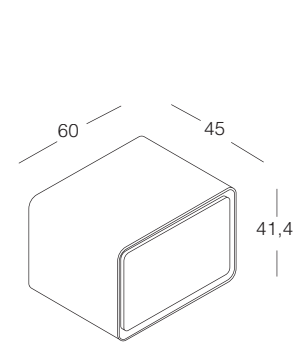

Serie contenitori eseguita in legno curvato con frontali cassetto laccati lucido. *Night table and chest of drawer in curved wood with drawer fronts finish glossy lacquer.*



**IL FASCINO ESERCITATO DA MANUFATTI
DI PREGIO OPPORTUNITÀ DI VEDERE
L'AMBIENTE CON UNA PROSPETTIVA
NUOVA DEL TUTTO UNICA.**

*PRECIOUS OBJECTS GIVING TO THE ROOM A NEW
AND ABSOLUTELY UNIQUE PERSPECTIVE.*

CONTEMPORANEO

Specchi

Mirrors

Imago	136
Tokyo	138
Venezia	140
Riflessi	142

Imago

DESIGN MARCO BOGA

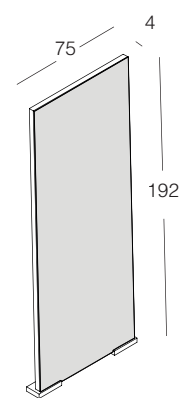

Specchio a terra con bordo perimetrale e piedini in legno. *Floor mirror with wooden edge and wooden feet.*



Tokyo

DESIGN MARCO BOGA

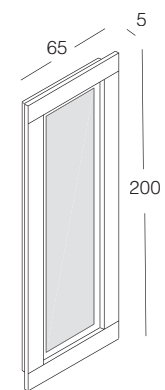

Specchio con cornice in legno.

Mirror with wooden frame.



Venezia

DESIGN MARCO BOGA / CASSINA

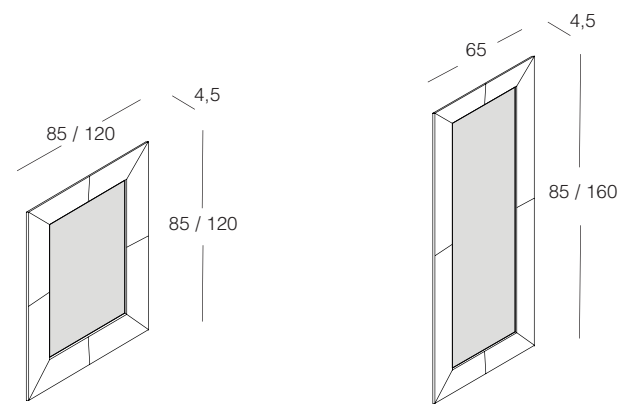

Specchio con cornice in legno nelle finiture foglia oro e foglia argento. *Mirror with wooden frame, gold and silver-foil finishes.*



Riflessi

DESIGN MARCO BOGA

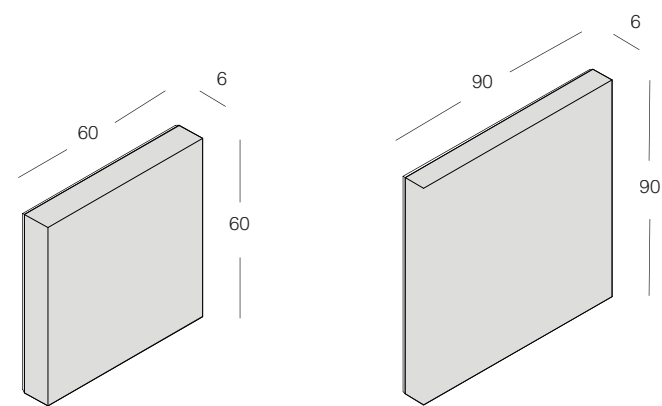

Specchio con bordo perimetrale finito a specchio.

Mirror with mirror edges.



**L'IMPRONTA, IL SEGNO DELL'ARTISTA
CHE UTILIZZA MATERIALI, DANDO FORMA
AD UN OGGETTO, ISPIRAZIONE DISTINTIVA
DI ELEMENTI PRIMARI E SOSTANZIALI
NELLA COLLEZIONE D'AUTORE, UNICI.**

*THE IMPRINTING, THE SIGN OF THE ARTIST MAKING USE
OF MATERIALS, GIVING SHAPE TO AN OBJECT. ESSENTIAL
ELEMENTS INSPIRING THE AUTHOR'S COLLECTION. UNIQUE.*

COLLEZIONI D'AUTORE

Poltrone e Divani *Armchairs and Sofas*

Serena	146
Feltrino	148
501	150
Intrecci poltrona	152
Intrecci divano	154
Intrecci collection 2-3-4 angolo	156
Luna di miele	158
Marilyn	160
Stealth	162
Boccaccio	164
Sartoriale	168



Serena

DESIGN MARCO BOGA - ALESSANDRO GEDDA

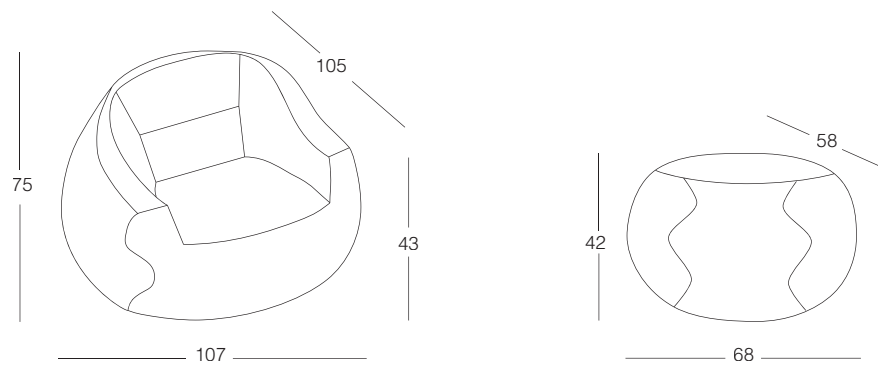

Poltrona con struttura in metallo annegato nel poliuretano con piastra girevole. Pouff in poliuretano espanso. Rivestimento in tessuto patchwork sfoderabile.

Armchair with metal structure embedded in polyurethane foam with swivel plate. Pouf in polyurethane foam. Removable cover in patchwork fabric.



Feltrino

DESIGN MARCO BOGA - ALESSANDRO GEDDA

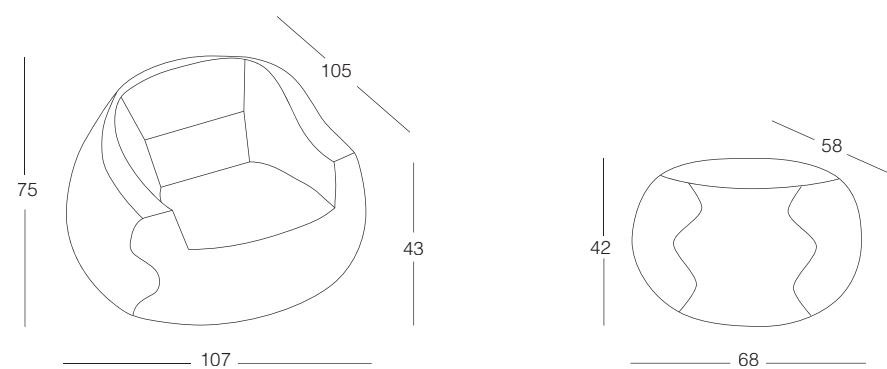

Poltrona con struttura in metallo annegato nel poliuretano con piastra girevole. Pouff in poliuretano espanso. Rivestimento in panno con impunture in contrasto sfoderabile.

Armchair with metal structure embedded in polyurethane foam with swivel plate. Pouf in polyurethane foam. Removable cover in felt fabric with contrasting stitching.



501

DESIGN MARCO BOGA - ALESSANDRO GEDDA

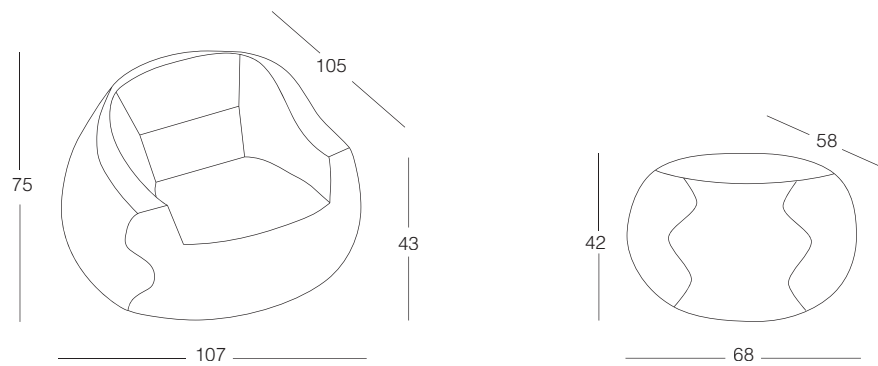

Poltrona con struttura in metallo annegato nel poliuretano con piastra girevole. Pouff in poliuretano espanso. Rivestimento in tagli di Denim sfoderabile.

Armchair with metal structure embedded in polyurethane foam with swivel plate. Pouf in polyurethane foam. Removable cover in cuts of denim fabric.



Intrecci poltrona

DESIGN ALESSANDRO GEDDA

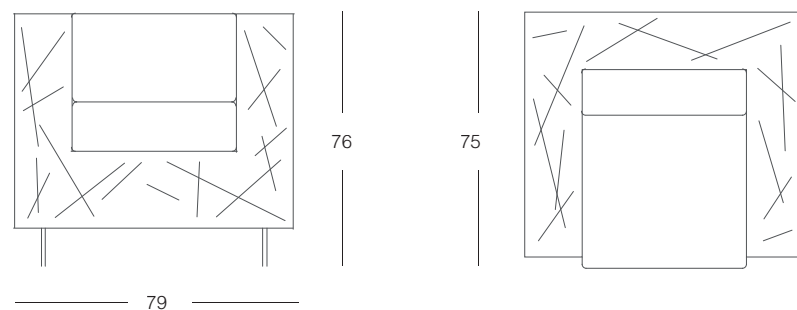

Poltrona destrutturata, realizzata con accostamenti e sovrapposizioni di listelli in legno massello. La casualità nell'applicazione dei listelli, realizzata interamente a mano, rende quest'opera un Masterpiece. Cuscino e schienale imbottiti. Rivestimento in tessuto sfoderabile cucitura con "Bordino" o in pelle sfoderabile cucitura doppio bordo accoppiato a vista.

Unstructured armchair, made with combinations and overlapping of solid wood strips. The randomness in the application of the strips, made completely by hand, makes this a Masterpiece. Upholstered seat and back cushion. Removable fabric cover, seam with "Bordino" or non removable leather cover with double edge at sight.



Intrecci divano

DESIGN ALESSANDRO GEDDA

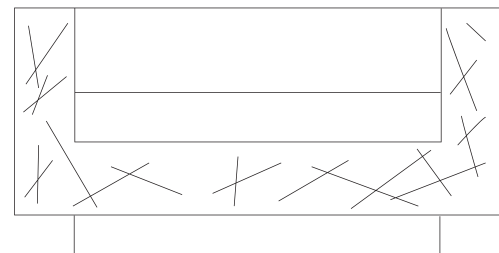

66

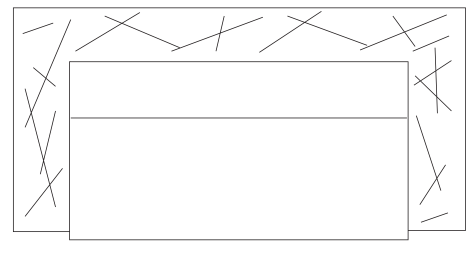

94

143 / 203 / 263

Divano destrutturato, realizzato con accostamenti e sovrapposizioni di listelli in legno massello. La casualità nell'applicazione dei listelli, realizzata interamente a mano, rende quest'opera un Masterpiece. Cuscino e schienale imbottiti. Rivestimento in tessuto sfoderabile cucitura con "Bordino" o in pelle sfoderabile cucitura doppio bordo accoppiato a vista.

Unstructured sofa, made with combinations and overlapping of solid wood strips. The randomness in the application of the strips, made completely by hand, makes this a Masterpiece. Upholstered seat and back cushion. Removable fabric cover, seam with "Bordino" or non removable leather cover with double edge at sight.

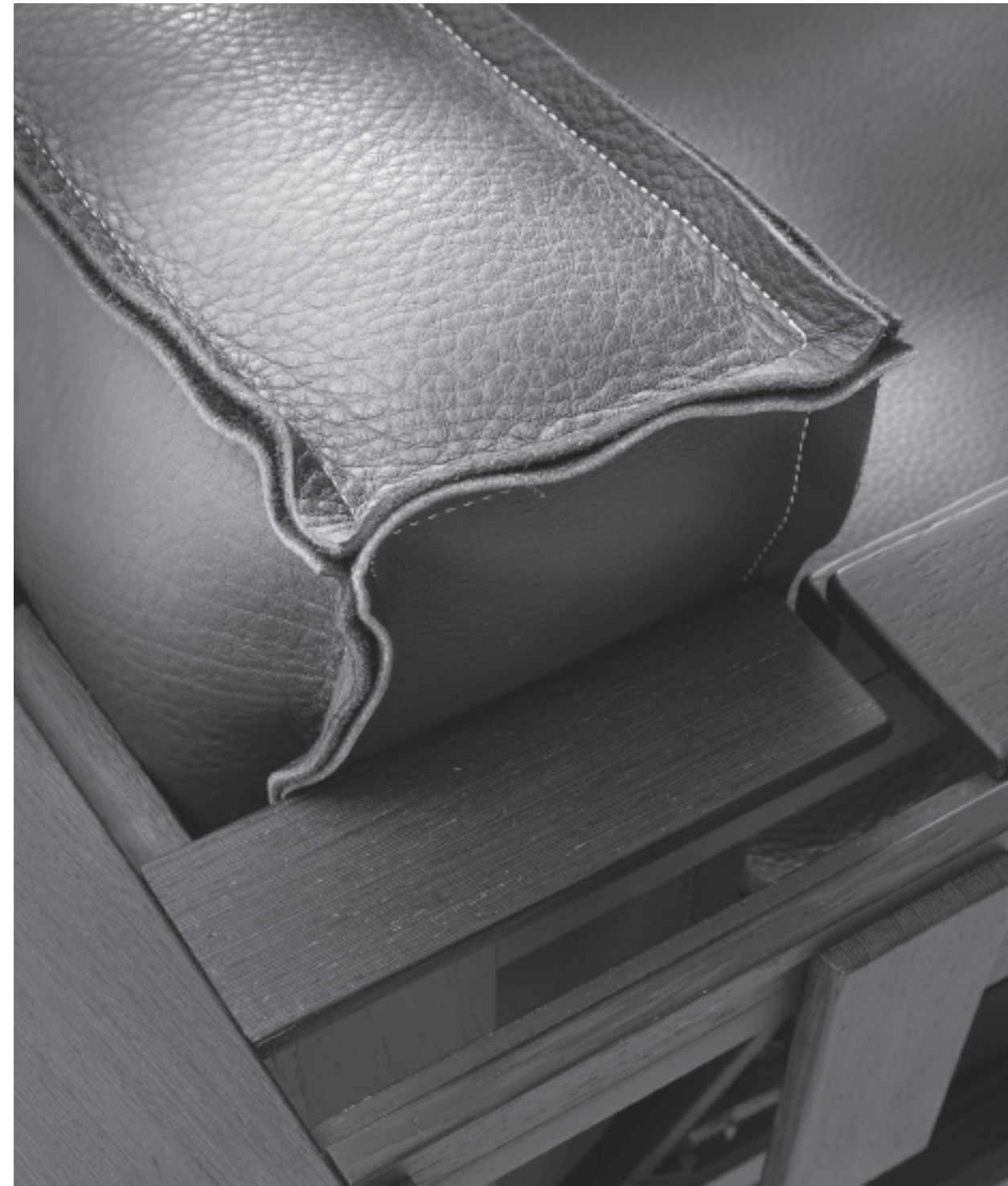

Intrecci collection 2-3-4 angolo

DESIGN ALESSANDRO GEDDA

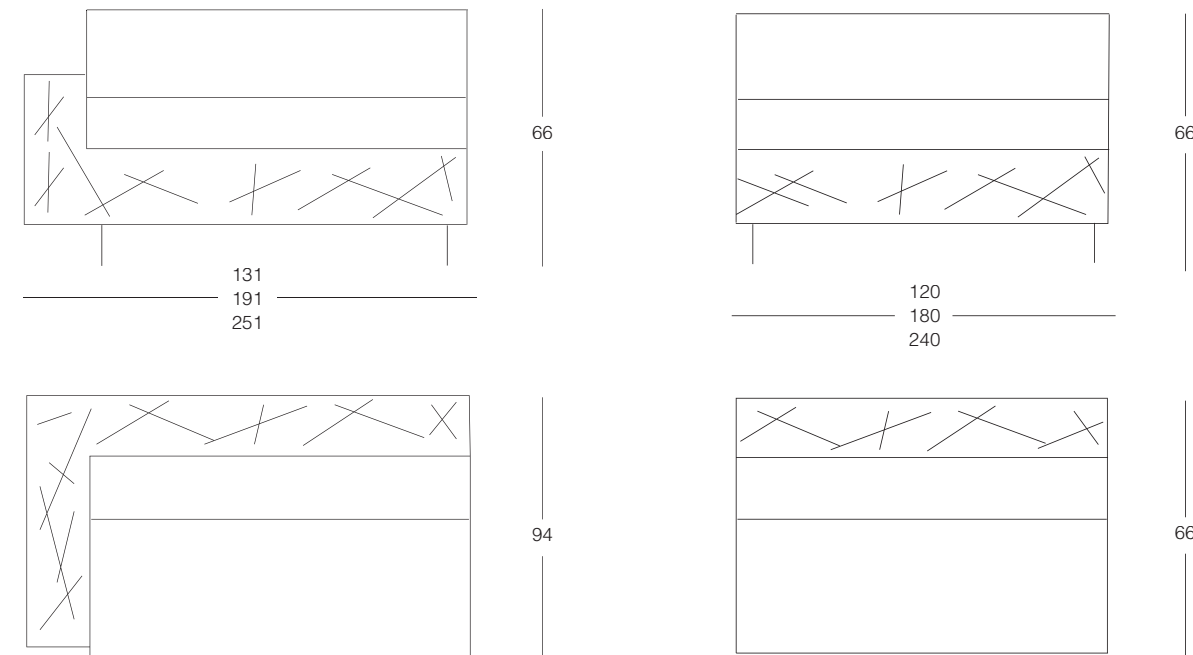

Sistema di sedute destrutturato, realizzato con accostamenti e sovrapposizioni di listelli in legno massello. La casualità nell'applicazione dei listelli, realizzata interamente a mano, rende quest'opera un Masterpiece. Cuscino e schienale imbottiti. Rivestimento in tessuto sfoderabile cucitura con "Bordino" o in pelle sfoderabile cucitura doppio bordo accoppiato a vista. Tavolino di raccordo triangolare.

Unstructured seating system, made with combinations and overlapping of solid wood strips. The randomness in the application of the strips, made completely by hand, makes this a Masterpiece. Upholstered seat and back cushion. Removable fabric cover, seam with "Bordino" or non removable leather cover with double edge at sight. Connection triangular small table.

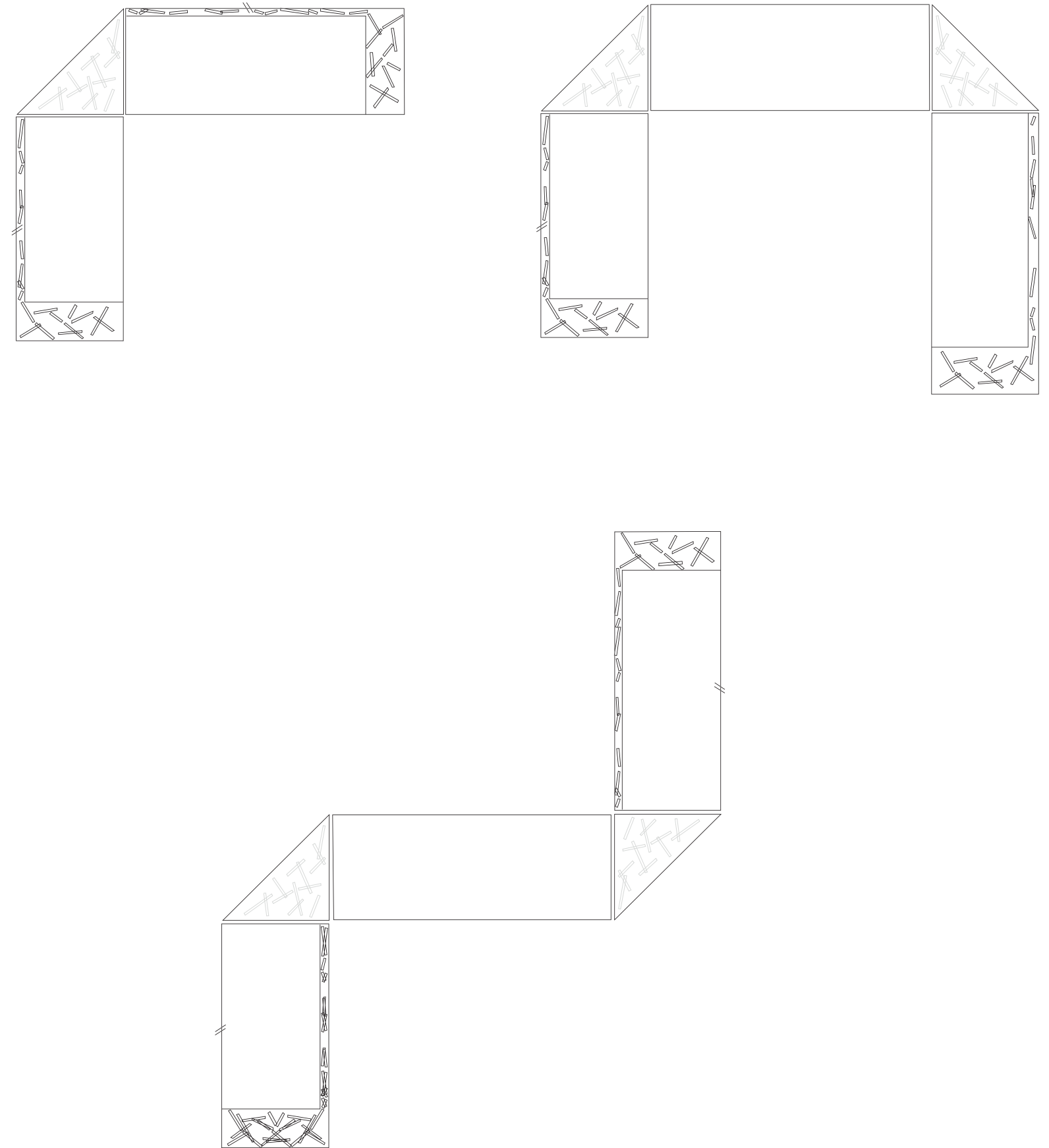

Luna di miele

DESIGN ALESSANDRO GEDDA

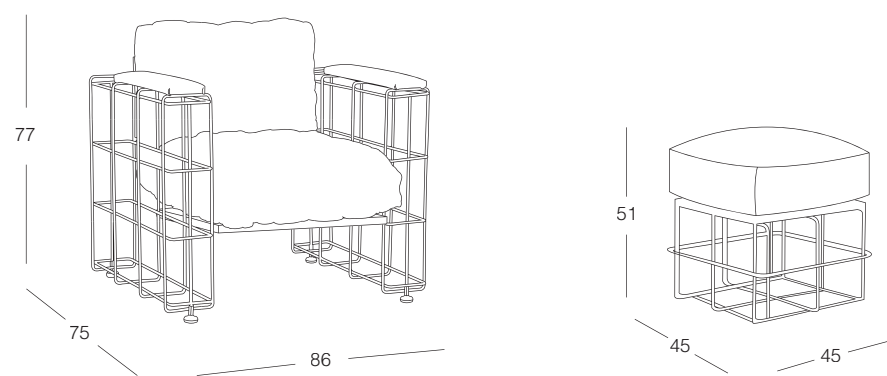

Poltrona con struttura in maglia di ferro, base e schienale in massello lamellare laccato nero.

Cuscino unico in schiuma simil spugna marina.

Armchair with structure in iron mesh, base and back multilayer panel, finish black lacquer.

Cushion in one piece, internal foam similar to sea-sponge.



Marilyn

DESIGN ALESSANDRO GEDDA



Divano componibile con base in acciaio, sedute rivestite in pelle Nabuk, schienale rialzato e piedini rivestiti in volpe.

Modular sofa with steel base frame, seating covered with non removable Nabuk leather, raised back and feet covered with fox fur.



Stealth

DESIGN ALESSANDRO GEDDA



Divano a segmenti irregolari con struttura in legno rivestito in poliuretano espanso a densità differenziata, cuscini in poliuretano espanso. Rivestimento in tessuto parzialmente sfoderale.

Sofa with irregular segments, wooden frame covered with different density polyurethane foam, cushions in polyurethane foam. Partially removable fabric cover.



Boccaccio

DESIGN CRS HALIFAX - ALESSANDRO GEDDA



Divano componibile con struttura in legno rivestita in poliuretano a densità differenziata. Cuscino schienale in piuma con inserto in poliuretano. Rivestimento in panno con impunture in contrasto sfoderabile.

Modular sofa with wooden frame covered with different density polyurethane foam. Backrest cushion in feather with polyurethane internal support. Removable cover in felt fabric with contrasting stitching.





Sartoriale

DESIGN CRS HALIFAX - ALESSANDRO GEDDA



Sistema di sedute con struttura in legno rivestito in poliuretano espanso a densità differenziata. Cuscini sedile e schienale in poliuretano espanso. Rivestimento fisso in pelle piumone con impunture a contrasto. Piedini e retroschiena in metallo finitura canna di fucile.

Seating system with wooden frame covered with different density polyurethane foam. Seat and back cushions in polyurethane foam.

Non removable piumone leather cover with contrasting stitching. Metal feet and back bar finish canna di fucile.



Marilyn

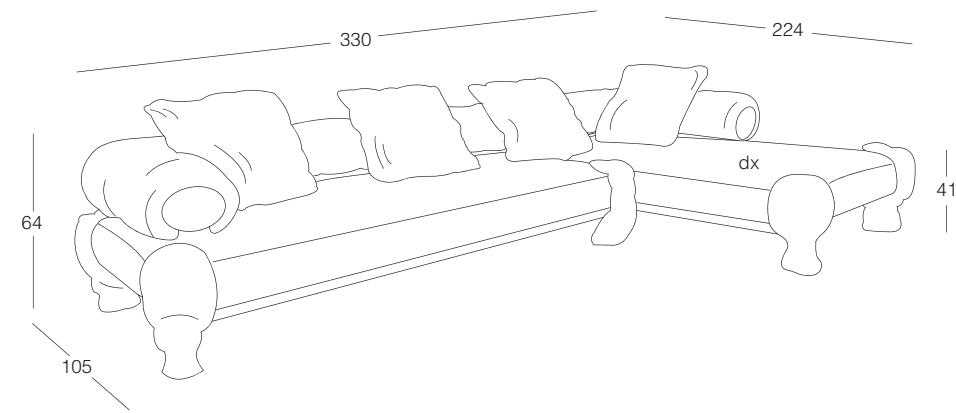

Stealth

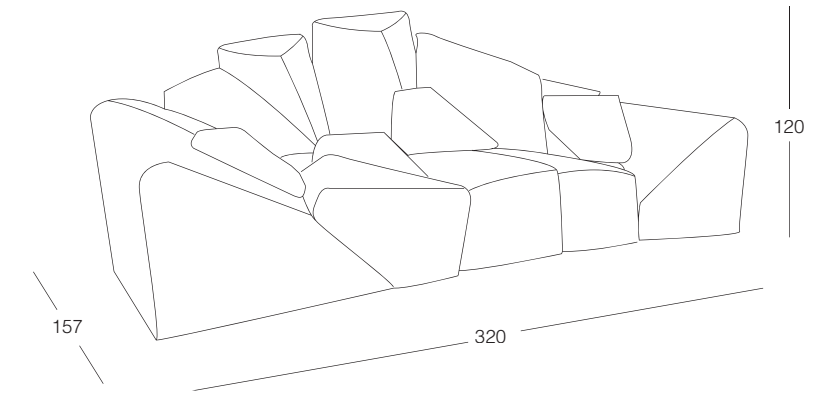

Boccaccio

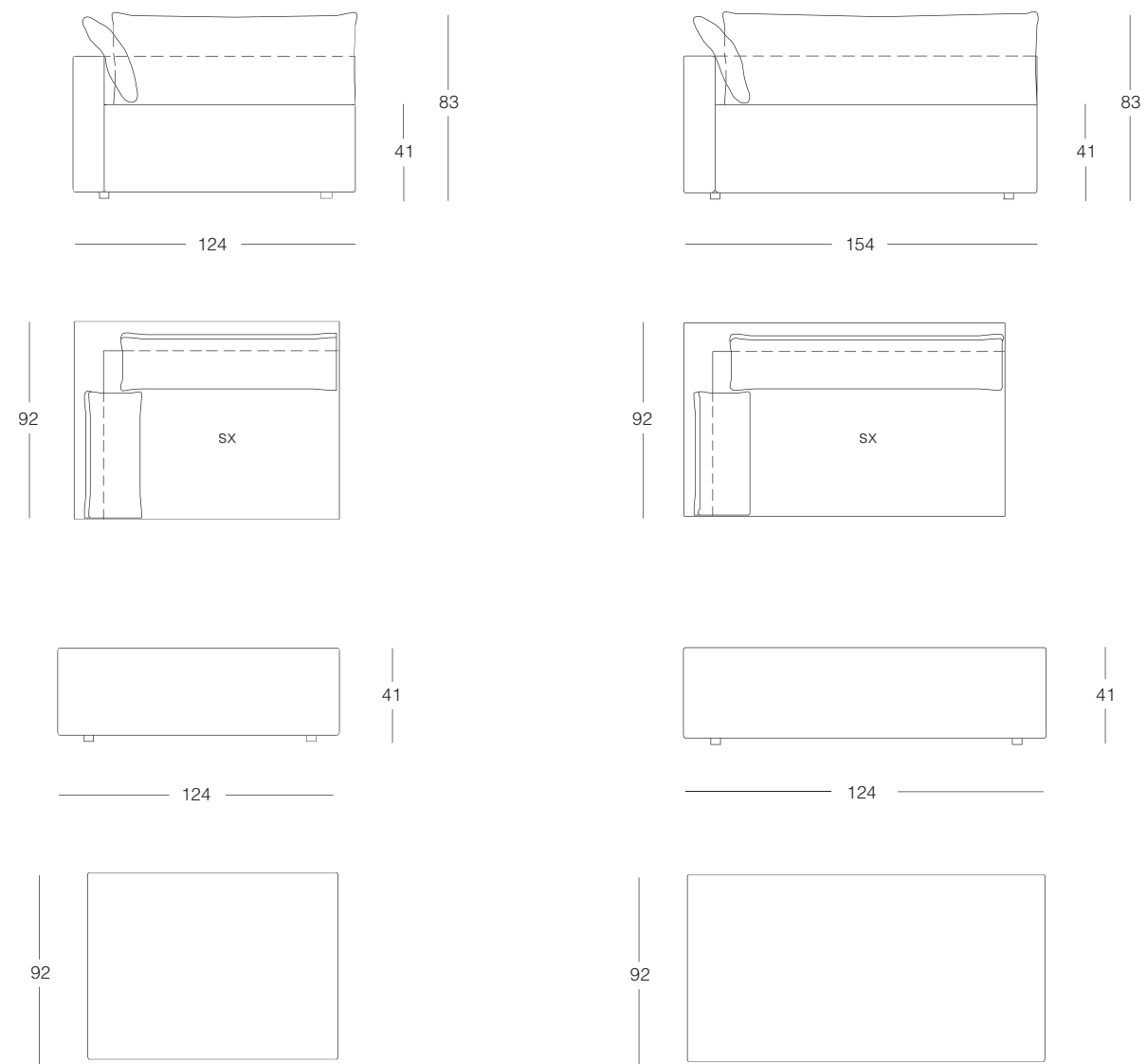

Sartoriale

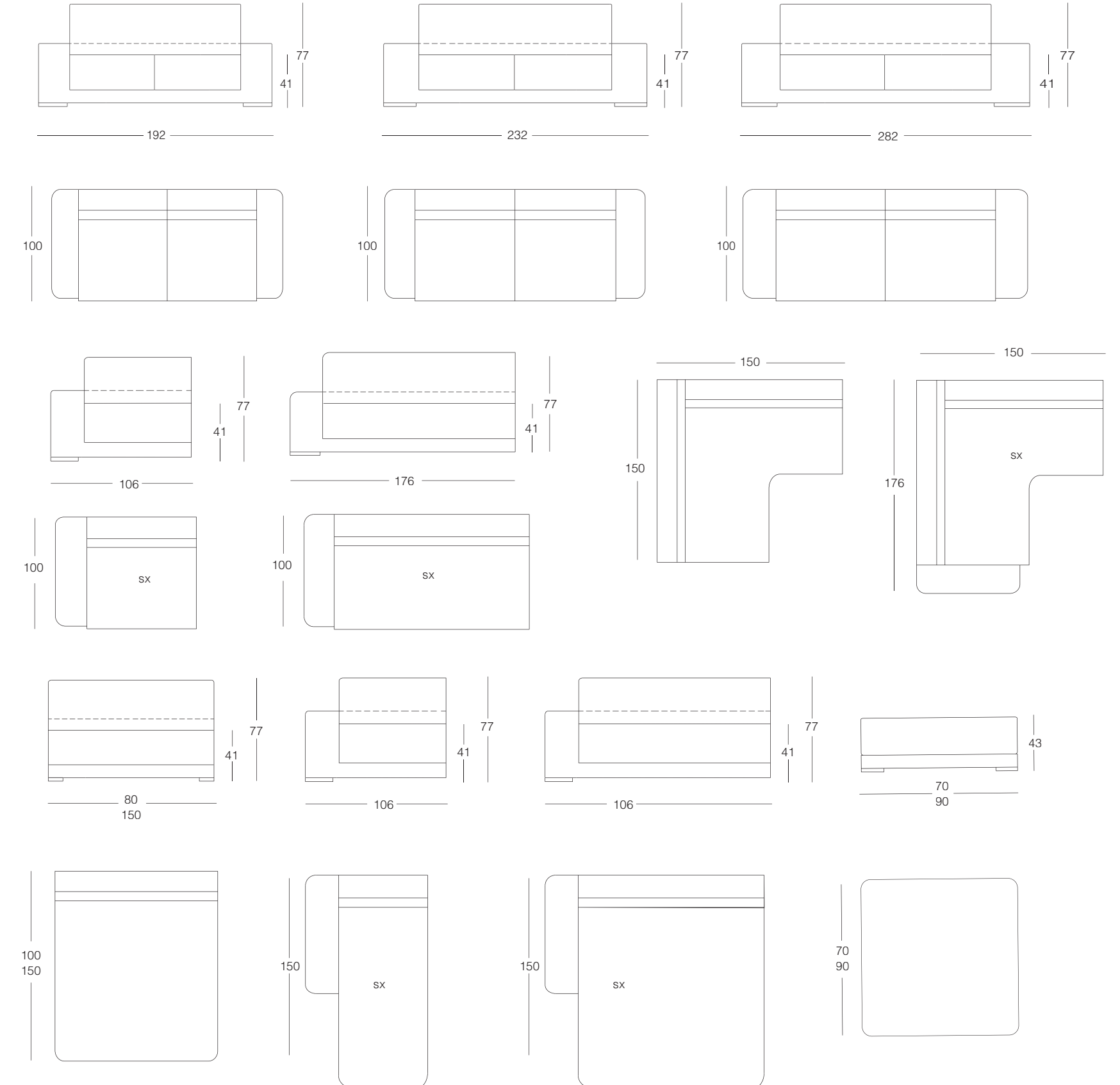



Colori
CROMO
BIANCO
ORO

TCLASO
CANN.F.
OPACO

BI SOLARE
OVALIFRATTO

Colori Tessuti
VIOLETTA
BLU
ARANCIO



COLLEZIONI D'AUTORE

Sedie
Chairs

Annette

176

Annette

DESIGN STUDIO SIGLA - ALESSANDRO GEDDA

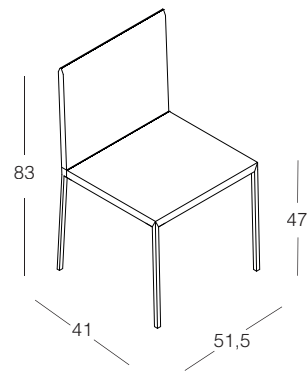

Sedia con struttura in profilato d'acciaio annegato nel poliuretano rivestita in cavallino, gambe in metallo finitura canna di fucile.

Chair with metal structure embedded in polyurethane foam covered with pony leather, metal legs finish canna di fucile.



COLLEZIONI D'AUTORE

Tavoli e Tavolini *Tables and Coffee Tables*

Righetta	180
Ivory - Black Swan fisso	182
Ivory - Black Swan 300	184
Ivory - Black Swan tavolino	186
Intrecci 9.9	190

Righetta

DESIGN CRS HALIFAX - ALESSANDRO GEDDA

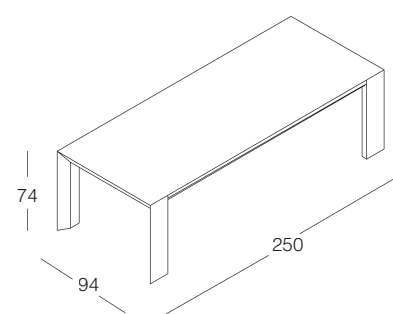
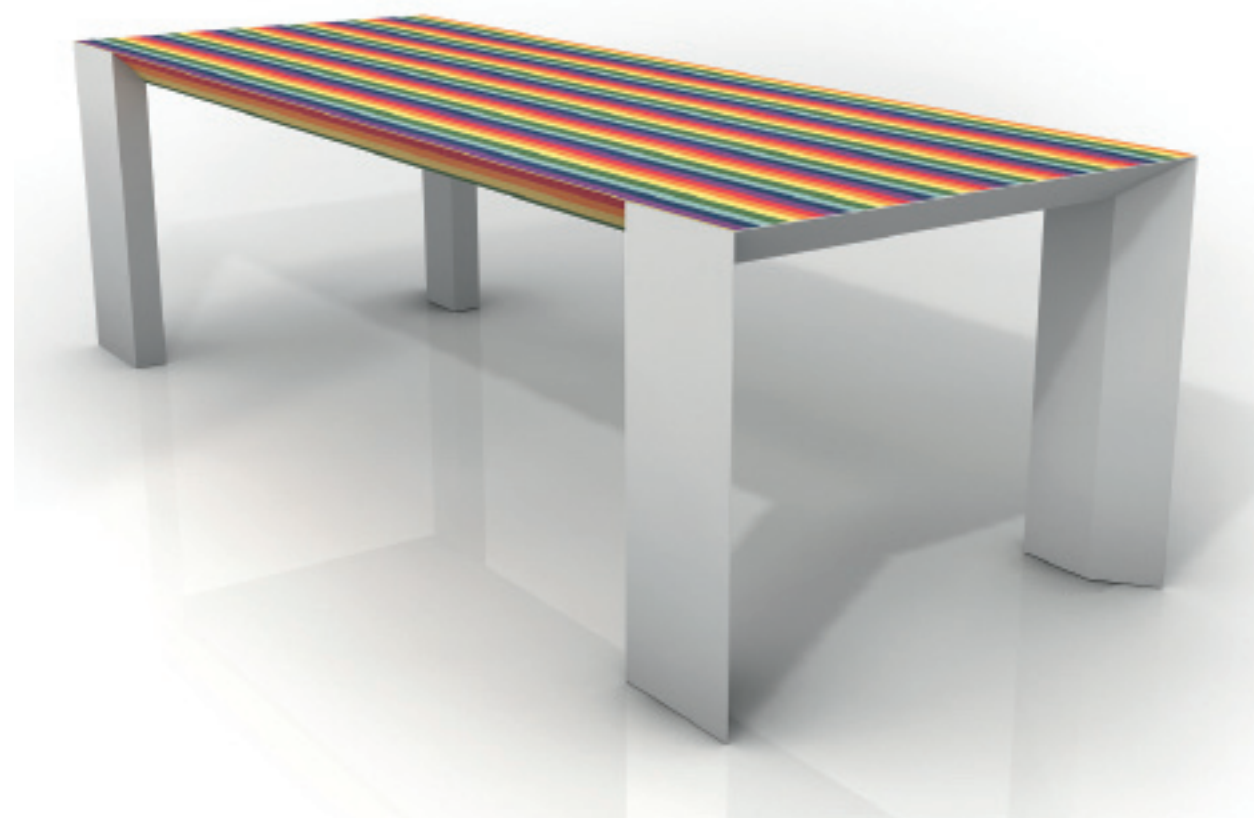

Tavolo rettangolare con gambe e piano in legno.
Gambe laccate bianco opaco, piano in legno ricomposto multicolor.

*Rectangular table with wooden top and legs.
White mat lacquered legs, top in multicolor recomposed wood.*



Ivory - Black Swan fisso

DESIGN LA MENSA - ALESSANDRO GEDDA

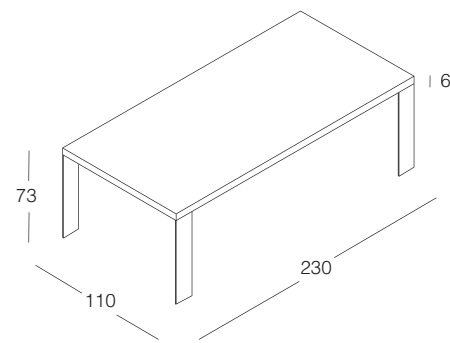

Tavolo rettangolare con piano in legno di forte spessore e gambe in metallo finitura canna di fucile.

Rectangular table with a thick wooden top and metal legs finish canna di fucile.



Ivory - Black Swan 300

DESIGN LA MENSA - ALESSANDRO GEDDA

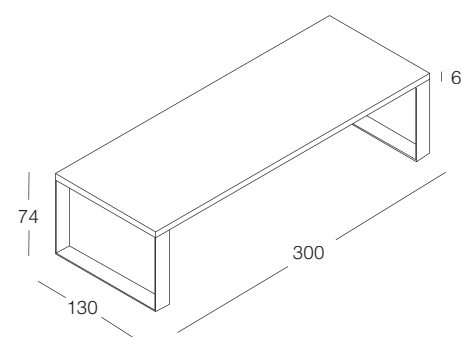

Tavolo rettangolare con piano in legno di forte spessore e gambe in metallo finitura canna di fucile.

Rectangular table with a thick wooden top and metal legs finish canna di fucile.



Ivory - Black Swan tavolino

DESIGN LA MENSA - ALESSANDRO GEDDA

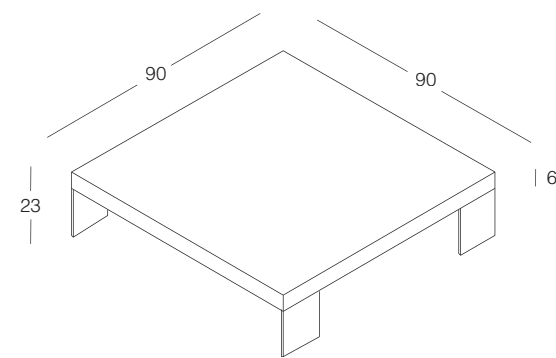
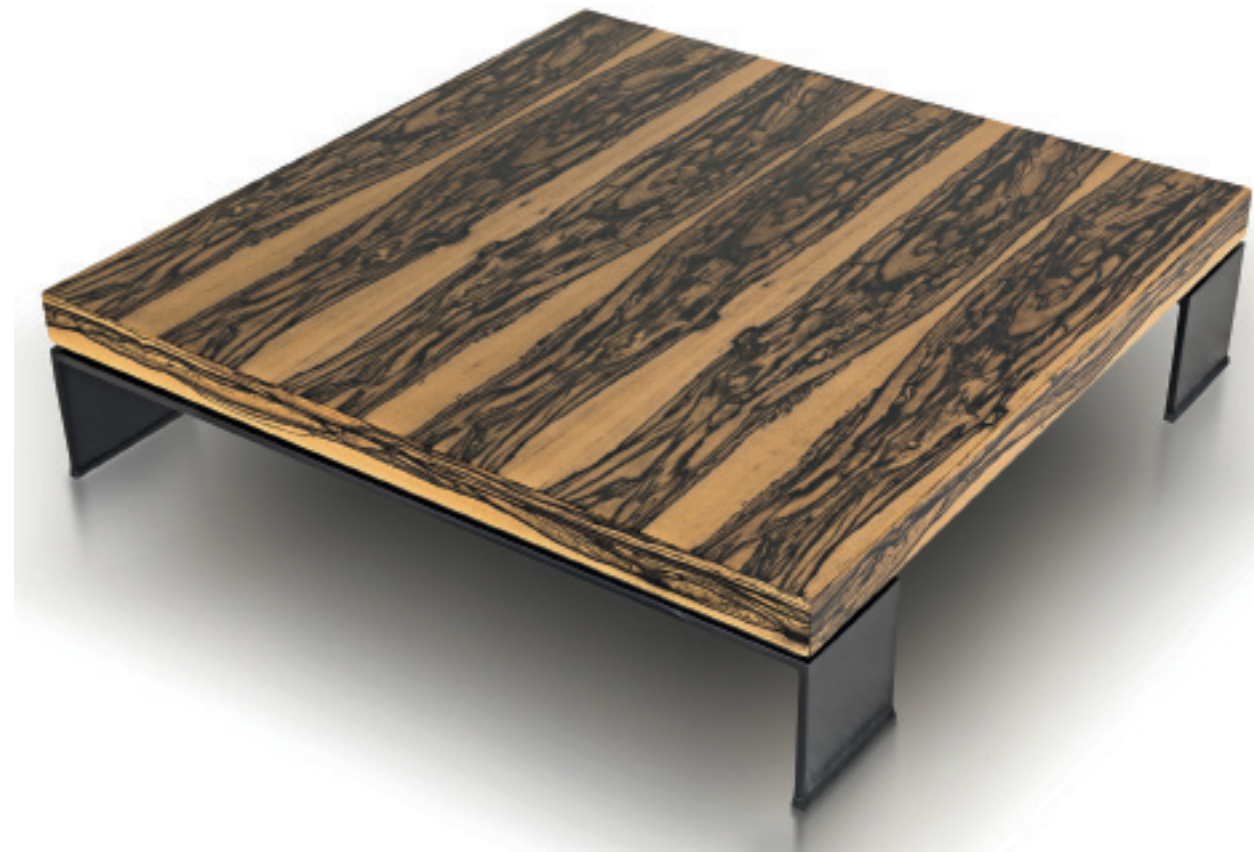

Tavolo basso con piano in legno e gambe in metallo
finitura canna di fucile.

*Coffee table with a thick wooden top and metal legs
finish canna di fucile.*





Intrecci 9.9

DESIGN ALESSANDRO GEDDA

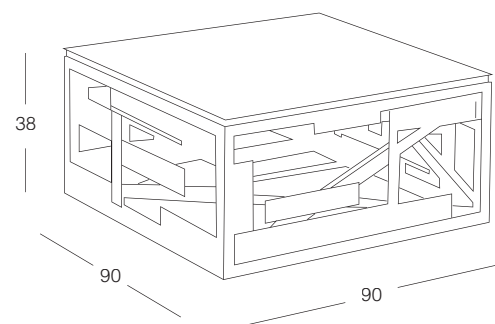

Tavolino destrutturato, realizzato con accostamenti e sovrapposizioni di listelli in legno massello.

Unstructured coffee table, made with combinations and overlapping of solid wood strips.



COLLEZIONI D'AUTORE

Contenitori e Librerie

Storage Units and Bookcases

Taglia e cucì	194
Ivory	196
Network	198

Taglia e cuci

DESIGN ALESSANDRO GEDDA

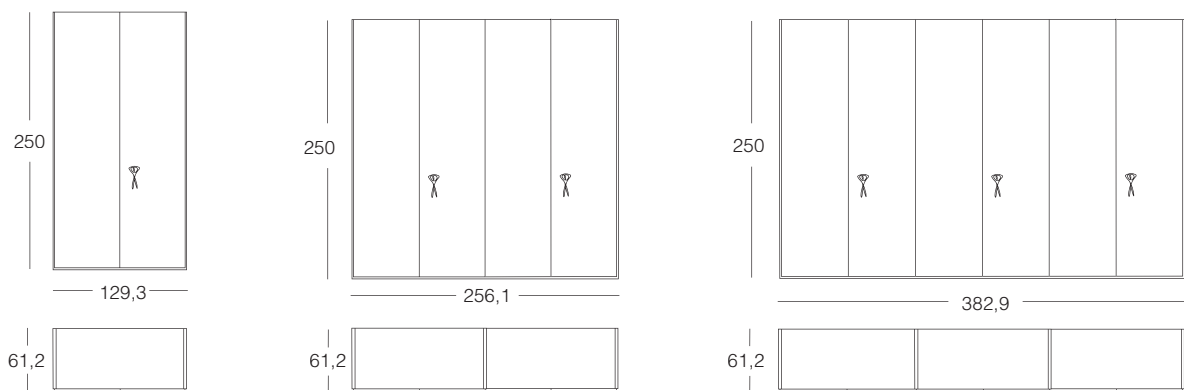

Contenitore con ante in legno ricomposto effetto gessato, una maniglia sartoriale, interni in colore, schienale a specchio.

Storage unit with wooden doors in recomposed veneer finish gessato, a tailoring handle, equipments in colour finish, mirror back panel.



Ivory

DESIGN ENRICO FRANZOLINI - ALESSANDRO GEDDA

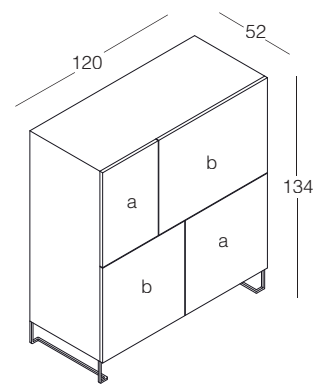

Contenitore in legno con struttura laccata nero e quattro ante in essenza ebano bianco. Piedini in metallo finitura canna di fucile.

Wooden storage unit with black lacquered structure and four doors in white ebony. Metal feet finish canna di fucile.



Network

DESIGN ALESSANDRO GEDDA

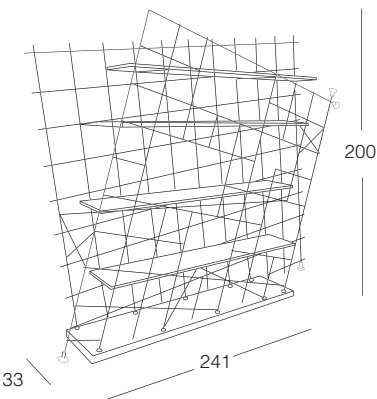
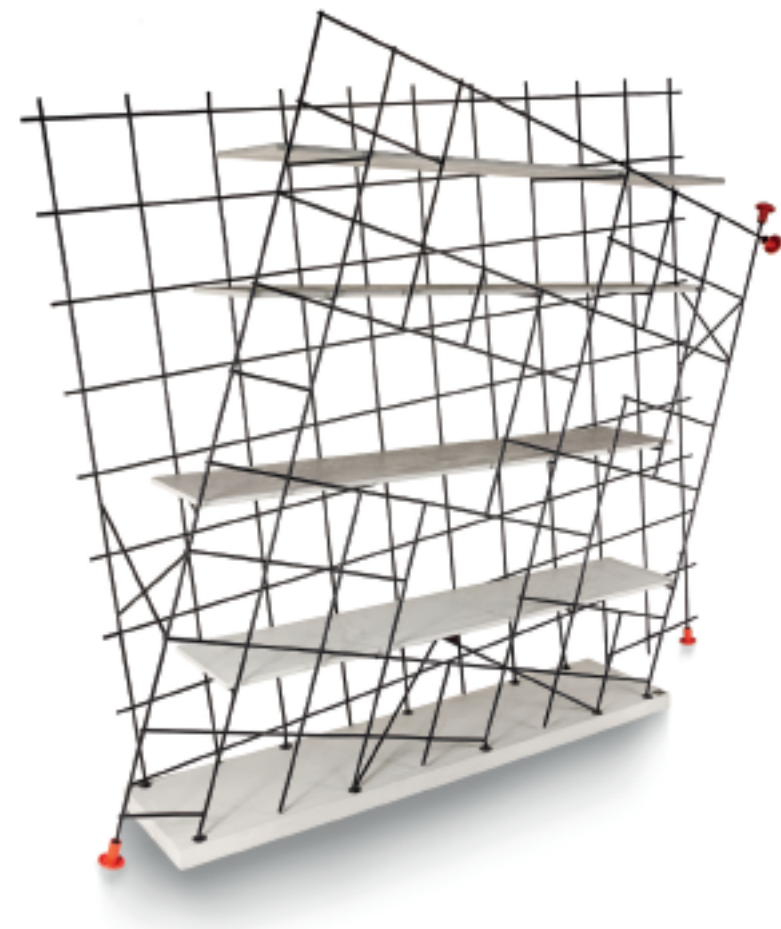

Libreria con struttura in maglia di ferro, base e piani in alluminio alveolare finitura cemento.

Bookcase with iron mesh structure, base and shelves in alveolar aluminium cement finish.



COLLEZIONI D'AUTORE

Letti

Beds

Le pieghe 202

Atelier 206

Le pieghe

DESIGN ALESSANDRO GEDDA

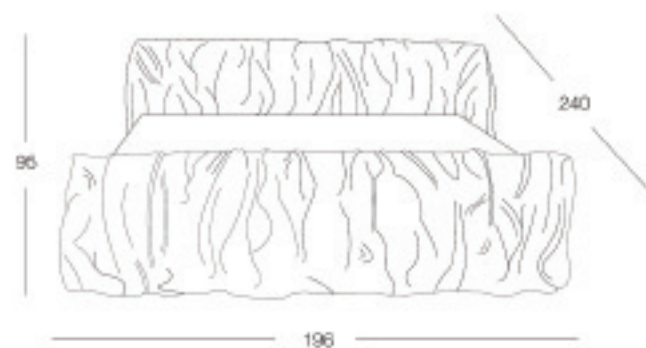

Letto con testata e pediera imbottite. Rivestimento in pelle Nabuk fisso.

Bed with upholstered headboard and footboard. Covered with non removable Nabuk leather.





Atelier

DESIGN CRS HALIFAX - ALESSANDRO GEDDA

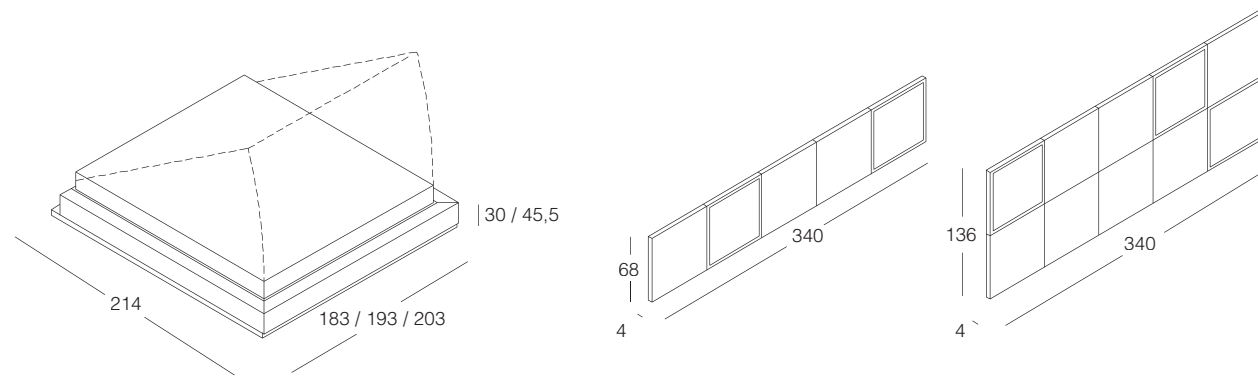

Letto con contenitore, con testata a pannelli e base imbottita. Rivestimento in pelle fisso con impunture a contrasto.

Storage bed with panels headboard and padded base. Non removable leather cover with contrasting stitching.



COLLEZIONI D'AUTORE

Comodini e Cassettiere

Night Tables and Chests of drawers

Le pieghe

210

Le pieghe

DESIGN ALESSANDRO GEDDA



Comodino con base in metallo e piano in legno, rivestito in pelle Nabuk fisso e piano in appoggio in vetro.

Night table with metal base and wooden top, covered with non removable Nabuk leather and overlaid glass top.

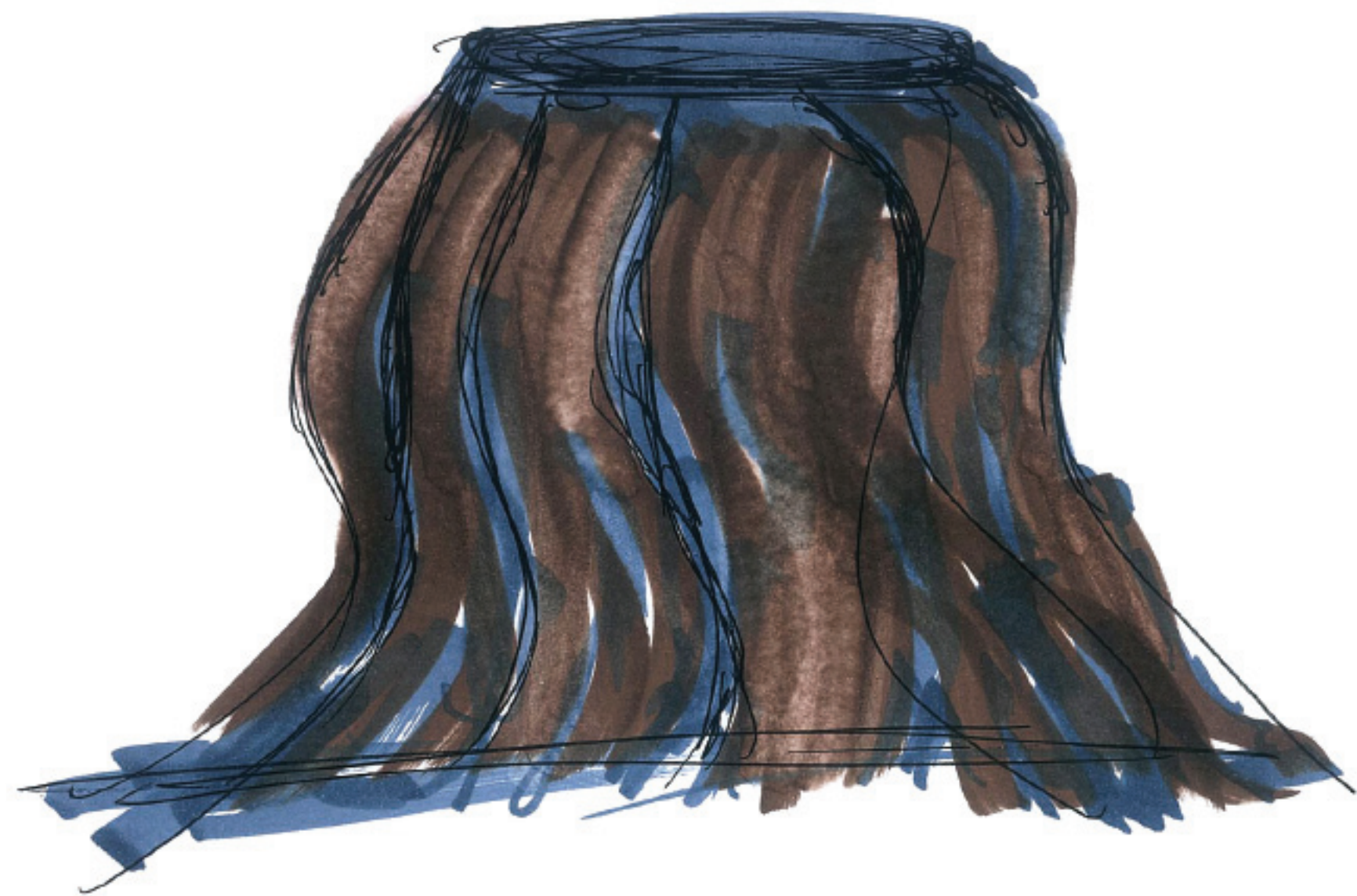

COLLEZIONI D'AUTORE

Specchi e Appendiabiti *Mirrors and Cloth-hangers*

Pittura fresca	214
Macchia	216
Righetta Specchio	218
Gessato Specchio	219

Pittura fresca

DESIGN ALESSANDRO GEDDA

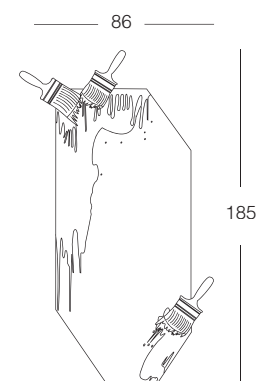
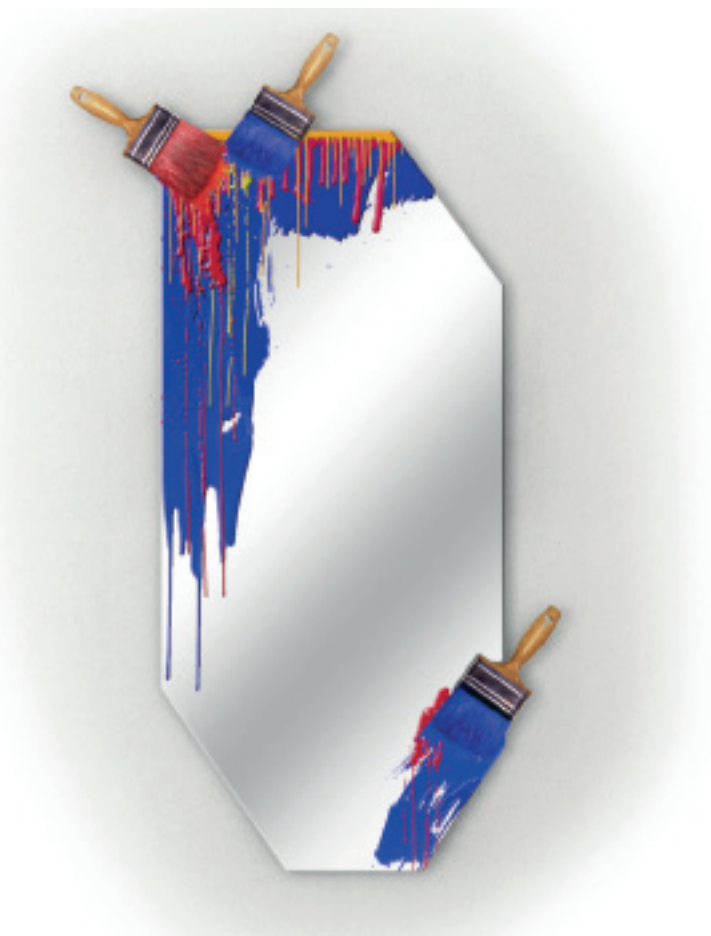

Specchio a muro con applicazioni di pennelli e macchie di colore. *Wall mirror decorated with paint brushes and colour spots.*



Macchia

DESIGN ALESSANDRO GEDDA

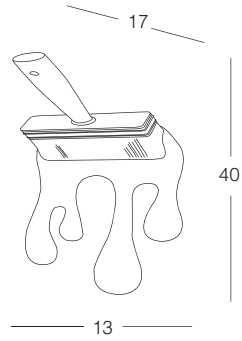

Appendiabiti da parete disponibile in vari colori.

Wall cloths hanger available in various colours.

Righetta Specchio

DESIGN MARCO BOGA - ALESSANDRO GEDDA

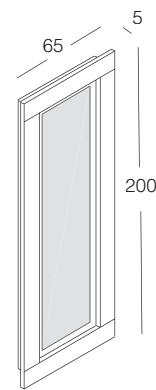

Specchio con cornice rivestita in legno ricomposto multicolor. *Mirror with frame finish multicolor recomposed wood.*

Gessato Specchio

DESIGN MARCO BOGA - ALESSANDRO GEDDA

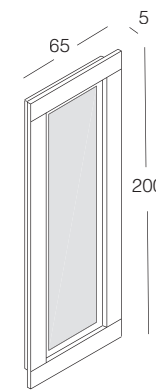

Specchio con cornice rivestita in legno ricomposto effetto gessato. *Mirror with frame finish gessato recomposed wood.*

**LEGNI, PLASTICA E FIBRA DI VETRO,
SI DISTINGUONO TRA I MATERIALI SEMPLICI
O COMPOSITI, CHE RICHIAMANO LA
TRADIZIONE E L'AVANGUARDIA, ROMPENDO
GLI SCHEMI DELLA CULTURA DELL'OUTDOOR.**

*WOOD, PLASTIC, GLASS FIBRE ARE AMONG THE SIMPLE
OR COMPOSITE MATERIALS EVOKING TRADITION
AND AVANT-GARDE, PROPOSING AN UNCONVENTIONAL
PROFILE OF THE OUTDOOR CULTURE*

OUTDOOR

Casper	222
Casper sofa	224
Casper chaise longue	226
Art Apple	227
Adamo&Eva	228
Nu.Ovo	230

Casper

DESIGN ALESSANDRO GEDDA

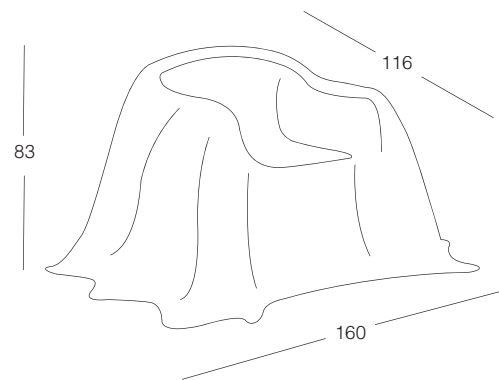

Poltrona monoscocca realizzata con materiale composito in VTR. Ideale in ambiente outdoor, adatto anche in interni. Finitura laccato lucido colore.

Monocoque armchair made of composite material VTR. Perfect for both outdoor and indoor. Glossy colour lacquer finish.



Casper sofa

DESIGN ALESSANDRO GEDDA

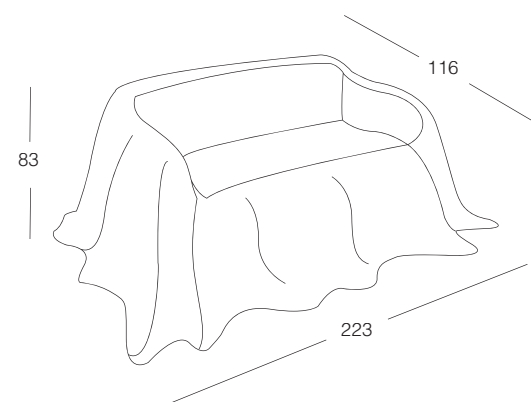

Divano monoscocca realizzato con materiale composito in VTR. Ideale in ambiente outdoor, adatto anche in interni. Finitura laccato lucido colore.

Monocoque sofa made of composite material VTR. Perfect for both outdoor and indoor. Glossy colour lacquer finish.



Casper chaise longue

DESIGN ALESSANDRO GEDDA

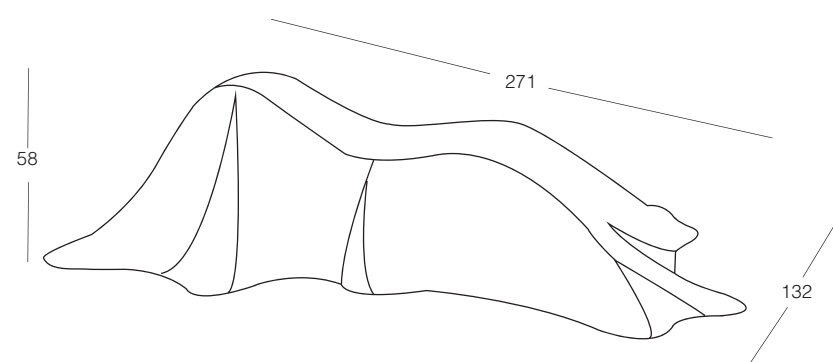

Chaise Longue monoscocca realizzata con materiale composito in VTR. Ideale in ambiente outdoor, adatto anche in interni. Finitura laccato lucido colore.

Monocoque chaise longue made of composite material VTR. Perfect for both outdoor and indoor use. Glossy colour lacquer finish.

Art Apple

DESIGN ALESSANDRO GEDDA

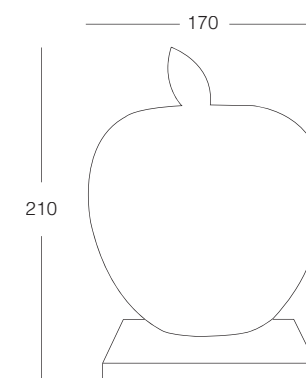

Scultura a forma di mela realizzata con materiale composito in VTR. Ideale in ambiente outdoor, adatto anche in interni. Finitura laccato lucido colore.

Sculpture with the shape of apple made of composite material VTR. Perfect for both outdoor and indoor. Glossy colour lacquer finish.

Adamo&Eva

DESIGN ALESSANDRO GEDDA

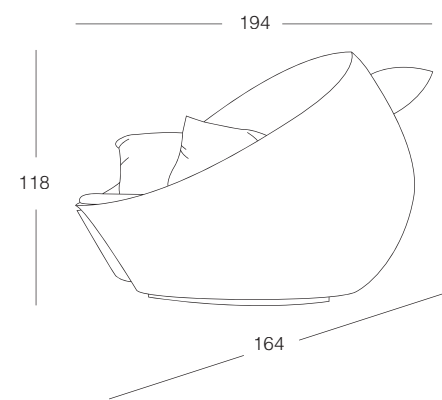

Divano monoscocca girevole realizzato con materiale composito in VTR. Seduta e cuscini imbottiti e rivestiti in tessuto sfoderabile. Ideale in ambiente outdoor, adatto anche in interni. Finitura laccato lucido colore.

Monocoque swivel sofa made of composite material VTR. Seating and cushions padded and covered with removable fabric. Perfect for both outdoor and indoor. Glossy colour lacquer finish.



Nu•Ovo

DESIGN PAOLO MALDOTTI

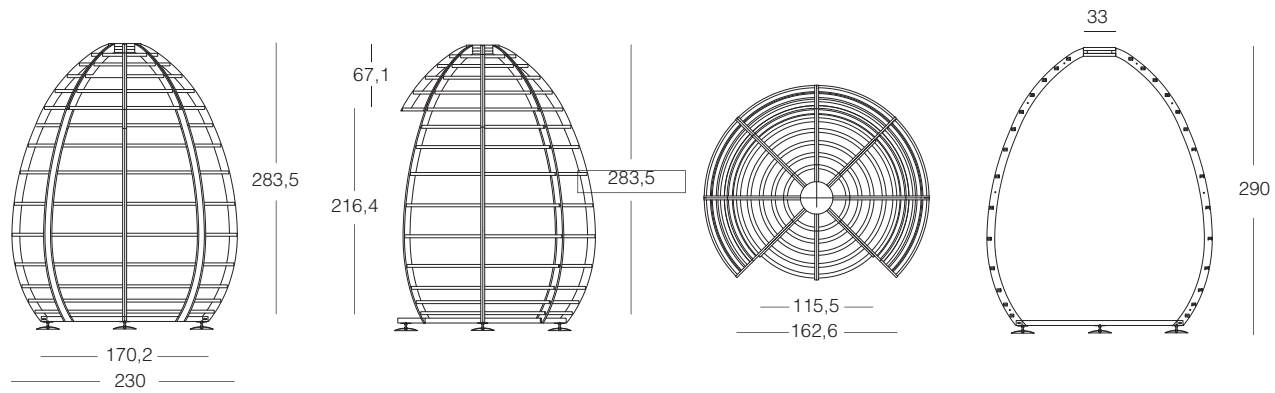

Nuova unità di misura dell'attività umana per creare nuovi ambienti negli ambienti. Una cellula abitativa polifunzionale da attrezzare a piacimento, pensata per la dimensione pubblica o privata, sia indoor che outdoor.

The new unit of measurement of the human activity to create new rooms inside other rooms. A multifunctional house unit to fit out as you like, thought for the public and private dimension both indoor and outdoor.



ma non i coperchi



