

olive

La storia

Art direction
Marco Romanelli

Graphic Design
Giuseppe Basile
con **Andrea Basile**

Fotografie
Gionata Xerra
con **Pierpaolo Mazzola,**
Leonardo Pelucchi
e **Danilo Pasquali**

Coordinamento
Franco Lettera

Giuseppe Ostuni e Joe Colombo, 1967



Fondata nel 1945 da Giuseppe Ostuni, maestro d'arte, O luce è, nel campo dell'illuminazione, la più antica azienda italiana di design ancora attiva. Prima del conflitto mondiale esisteva infatti la sola Arteluce di Gino Sarfatti, scomparsa alla fine degli anni '90, nel 1948 nasceranno Azucena e Lamperti, nel 1950 Arredoluce e Stilnovo. Saranno però soprattutto Arteluce, Azucena e O luce a focalizzare, per lunghi anni, il panorama italiano, costituendosi quali centri di incontro per quei progettisti che, fortemente coinvolti dalla ricostruzione prima e dalla nascita della produzione in serie poi, animavano il dibattito milanese: Vittoriano Viganò e i BBPR, Gigi Caccia Dominioni e Ignazio Gardella, Marco Zanuso e infine Joe Colombo. Già nel 1951 O luce partecipa, con successo, alla IX Triennale, presentando, nella sezione dell'illuminazione, curata da Achille, Livio e Pier Giacomo Castiglioni, un Luminator disegnato da Franco Buzzi. L'azienda, com'era tipico nella storia di quel periodo, raggiunge subito, grazie alla rivista Domus, un pubblico internazionale. I cataloghi degli anni '50 testimoniano della peculiarità del lavoro di Ostuni, lavoro ancora sostanzialmente da indagare in chiave critica. Un grande successo è sancito da Tito Agnoli con le segnalazioni alla seconda edizione del Compasso d'Oro, nel 1955, di due lampade (il modello da terra 363 e uno speciale modello per libreria). Nel 1956 seguiranno, in rapida sequenza, altre due segnalazioni: per una notevolissima lampada da tavolo in polivinile a lamelle e per un apparecchio a sospensione (mod. 4461) con doppio diffusore in perspex. Fondamentale infine ricordare, nel 1954, l'apparecchio 255/387 (detto "Agnoli"), esile tige che regge uno spot, a segnare la fine dei paralumi e l'adozione di lampade da terra molto semplificate anche nell'illuminazione domestica. Oltre ad Agnoli, con Ostuni lavorano: Forti, dimenticato interprete delle nuove esigenze abitative della borghesia milanese, Arnaboldi, Monti e Minale. Ma è alla fine del decennio, e precisamente grazie all'incontro con Joe e Gianni Colombo, che O luce acquista una più precisa carica rivoluzionaria. I fratelli Colombo (poi solo Joe proseguirà le sue acuminata incursioni nel mondo degli oggetti, dedicandosi Gianni all'arte pura) cercavano un interlocutore in grado di reagire alle loro provocazioni: lo troveranno in Ostuni. Innanzitutto nascerà la lampada da tavolo 281, conosciuta come "Acrilica", presente nel catalogo O luce dal 1962. Curva di spessissimo perspex lungo cui la luce pare risalire, essa rimane da un lato come dimostrazione di un possibile punto di incontro tra arte e design, dall'altro come testimonianza di un uso colto dei nuovi materiali. Medaglia d'oro alla XIII Triennale, la stessa in cui Joe Colombo otterrà anche due medaglie d'argento (per il "Combi-Center" e la "Mini-Kitchen"), "Acrilica" posiziona la figura di Joe Colombo tra i grandi interpreti dell'epoca. Intanto, nel 1963, in produzione dal 1965, Marco Zanuso disegna per O luce un dimenticato capolavoro, la lampada da tavolo modello 275 con grande diffusore in perspex bianco orientabile a rotazione su di una base in metallo laccato. Nel 1964/66, nuovamente da un materiale, il vetro stampato detto "Lente Fresnel", nascerà, con Joe Colombo, la famiglia di lampade stagne da esterno "Fresnel" con base in metallo verniciato e diffusore trattenuto da mollette d'acciaio. Seguirà, nel 1965, il gruppo "Spider" ove un unico corpo illuminante, disegnato come risposta alla Cornalux, speciale lampadina a spot orizzontale, veniva montato, grazie ad uno snodo in melamina, in diverse situazioni (casa/ufficio) e su diversi supporti (tavolo/terra/parete/soffitto), impostando il concetto stesso di "famiglia" di lampade. La lamiera stampata, verniciata a fuoco in bianco, in nero, ma anche in arancio e marrone, scorrevole sulla tige cromata lucida, parlava del futuro. Nel 1967 "Spider" vince il primo Compasso d'Oro per la O luce e, nel 1972, è a New York per la indimenticabile mostra "Italy: the New Domestic Landscape". Nel 1967 Colombo è però già "più avanti" e, con il modello "Coupé", conservato al MoMA di New York, propone uno stelo curvo di notevoli dimensioni a sorreggere una elegantissima calotta semi-cilindrica. La "Coupé" vince, nel 1968, lo "International Design Award" dell'American Institute of Interior Designers di Chicago. Nel 1970 infine, entrata in produzione nel 1972 ad un anno dalla prematura scomparsa di Joe Colombo, nasce la "Lampada alogena", necessariamente da allora chiamata "Colombo". Prima alogena per interni ad apparire sul mercato, icona insuperata di un design assieme funzionale e contemporaneo. Intanto però alla O luce è iniziata una nuova importantissima epoca, coincidente

con il passaggio della proprietà da Giuseppe Ostuni alla famiglia Verderi e contrassegnata dalla preponderante figura di uno dei grandi maestri del design italiano: Vico Magistretti. Per molti anni Magistretti sarà art director e principale designer della compagnia, lasciando in essa una traccia inconfondibile e un patrimonio di riconoscibilità diffuso nel mondo intero. Kuta, Lester, Nara, Idomeno, Pascal, Dim, Sonora, Snow, ma soprattutto Atollo, divengono nomi capaci di evocare il prodotto corrispondente. "Atollo" si trasforma addirittura in una sagoma, una silhouette grafica in grado di suggerire il concetto stesso di "lampada". "Atollo", imitata nel mondo intero, ma sostanzialmente inimitabile, vincitrice del Compasso d'Oro nel 1979, presente nelle collezioni permanenti dei maggiori musei di design e arti decorative del mondo, è quindi ormai molto di più che una lampada. E' un mito. Il suo segreto sta probabilmente nella costruzione geometrica delle forme: il cono sul cilindro e sopra a tutto la semisfera. Scultura luminosa cui nulla è possibile togliere, nulla è possibile aggiungere. La presenza di Magistretti preserva intanto O luce da facili incursioni nelle poetiche post-moderne, come è dimostrato dalla presenza in catalogo di numerosi pezzi di Bruno Gecchelin. All'inizio degli anni '90, sarà il rigore dello svizzero Hannes Wettstein, allora designer emergente, a caratterizzare la filosofia dell'azienda. Ricordiamo, dello stesso Wettstein, il modello "Soirée", esile assemblaggio di alluminio e makrofol. Parallelamente trovano spazio le ironiche provocazioni di Riccardo Dalisi con i modelli "Sister" e "Zefiro". Nel 1995, O luce inizia un nuovo corso che, attraverso la art direction di Marco Romanelli, potenzia il successo internazionale e il riconoscimento critico della collezione. La nuova formula si incentra sulla valorizzazione di linguaggi estremamente differenti e personali in particolare appartenenti ad esponenti di spicco della ricerca contemporanea quali l'inglese Sebastian Bergne, lo svizzero Hans Peter Weidmann, gli italiani Laudani&Romanelli. Nel 1997 la lampada "Estela" è il primo oggetto in produzione industriale dei fratelli Fernando e Humberto Campana, poetici interpreti del loro lontano Brasile. Nel 2000 con la serie "Nuvola" inizia a collaborare con O luce Toni Cordero. Tra i maggiori architetti italiani della sua generazione, Cordero si impone per le sue forme assolutamente dirompenti e non omologate. "Nuvola" sarà il suo ultimo straordinario progetto.

Nel 2001 sassi in bianco vetro di Murano e canne in perspex trasparente popolano lo stand O luce ad Euro luce. Disegnati rispettivamente da Laudani&Romanelli e da Ferdi Giardini propongono un modo di intendere il design che superi la funzione per farsi poesia. Su questo sentiero prosegue la ricerca di autorevoli voci internazionali che possano declinare le tipologie dell'illuminazione secondo la filosofia di O luce. Il compatto gruppo di progettisti si arricchisce allora inglobando l'americano Tim Power, il finlandese Harri Koskinen e l'italiano Carlo Colombo.

Il nuovo millennio si apre quindi, per O luce, con nuove collaborazioni e una nuova energia. Da un lato vengono esplorati territori al confine della luce: Ferdi Giardini propone con "Nerolia" una lampada diffusore di essenze profumate, Francesco Rota, con "Ibiza", un apparecchio da esterno che contiene un sofisticato altoparlante, Laudani&Romanelli, con "Cand-led", una candela luminosa svincolata dalla presa e ricaricabile come i telefoni cellulari. Harri Koskinen, il giovane finlandese che è stato capace di rilanciare il design nordico sulla scena internazionale, alla sua prima prova oltre i confini nazionali, immagina, con "Lamppu", una lampada da lettura con testa amovibile e utilizzabile come torcia. Ciascuno di questi progetti apre una preziosa linea di ricerca e di innovazione. Nel 2005 entra nella squadra O luce, con "Sorane" prima e quindi con "Switch", Oki Sato, ovvero Nendo, il più raffinato tra i nuovi progettisti giapponesi.

Ma la volontà di O luce di indagare nuovi linguaggi non è ancora paga e così due maestri del design internazionale quali il giapponese Toshiyuki Kita e l'italiana Antonia Astori hanno recentemente proposto lampade come pezzi assoluti, poeticamente "fuori dal tempo" e quindi destinati a trasformarsi rapidamente in classici. Parallelamente O luce continua ad indagare i più diversi ed estremistici terreni semantici, dall'espressionismo sculturale del francese Emmanuel Babled al minimalismo funzionalista del tedesco Lutz Pankow. Ma questa, ormai, non è più la storia dell'O luce, piuttosto l'apporto della O luce al design contemporaneo.



The history

Established in 1945 by the master Giuseppe Ostuni, O luce is the oldest Italian lighting design company that is still active today. In fact, before the war there existed only Gino Sarfatti's Arteluce, which disappeared in the late '90s, while 1948 saw the birth of Azucena and Lamperti, followed by Arredoluce and Stilnovo in 1950. But for many years it was chiefly Arteluce, Azucena and O luce that dominated the Italian scene, creating a hub for the designers – strongly engaged first in the reconstruction and later in the birth of series production – who animated the Milanese forum: Vittoriano Viganò and BBPR, Gigi Caccia Dominioni and Ignazio Gardella, Marco Zanuso and Joe Colombo. As early as 1951, O luce registered a success at the IX Triennale, in the lighting section directed by Achille, Livio and Pier Giacomo Castiglioni, with an indirect incandescent luminaire designed by Franco Buzzi. The company, as it was during that period, quickly reached an international public through Domus magazine, thanks to the vision of Gio Ponti. Its '50s catalogues confirm the individuality of Ostuni's work, which has yet to be fully examined in critical key. Tito Agnoli achieved an important success in 1955, with mentions at the second "Compasso d'Oro" for two of his lamps (a floor lamp, mod. 363, and a special model for bookshelves). In 1956 two other mentions followed in rapid succession: for a truly remarkable table lamp in laminar polyvinyl, and for a pendant light (mod. 4461) with double perspex shade. And then there was the ground-breaking "Agnoli" model (255/387), a spot light supported on a slender stem, which in 1954 marked the decline of lampshades and the rise of highly simplified floor lamps, even for domestic lighting. In addition to Agnoli, Ostuni's collaborators included: Forti, the forgotten advocate of a new living style for the Milanese high middle class, as well as Arnaboldi, Monti and Minale. But it was only at the end of the decade, thanks to the encounter with Joe and Gianni Colombo, that O luce took a more pronounced revolutionary slant. The Colombo brothers (subsequently only Joe pursued his incisive sorties into the world of objects, while Gianni devoted himself to the fine arts) were seeking a receptive environment for their audacious designs: this was O luce. First there was the "Acrilica" table lamp (mod. 281), included in the O luce catalogue as of 1962: a very thick perspex curve through which the light appears to climb, exemplifying both a possible meeting point between art and design, as well as an elegant use of new materials. A gold medal winner at the XIII Triennale, where Joe Colombo also won two silver medals (for the "Combi-Center" and the "Mini-Kitchen"), the "Acrilica" consolidated Joe Colombo as one of the great designers of the day. Meanwhile, in 1963, Marco Zanuso created one of O luce's forgotten masterpieces in production since 1965: the model 275 table lamp with large white perspex swivel shade on an enamelled metal base. And it was once again a new material, the "Fresnel Lens" pressed glass, which inspired Joe Colombo's 1964/66 family of weatherproof outdoor "Fresnel" lights, with a painted metal base and shade retained by steel clips. This was followed in 1965 by the "Spider" group, in which a single lighting fixture, designed for a special horizontal spot light, was assembled – thanks to a melamine joint – in a variety of situations (home/office) and on different supports (table/floor/wall/ceiling), thus coining the concept of a "family" of lamps. The stamped plate finished with white, black, orange or brown baking paint, sliding along a polished chrome stem, seemed a foretaste of the future. In 1967 it won the first "Compasso d'Oro" award for O luce, and in 1972 it appeared at the unforgettable New York exhibition "Italy: the New Domestic Landscape". But in 1967 Colombo had already moved on, creating his "Coupe", a curved stem of considerable size supporting an elegant semi-cylindrical shade, now exhibited at the MoMA in New York. In 1968 the "Coupe" light won the "International Design Award" of Chicago's American Institute of Interior Designers. Finally, 1970 saw the birth of the "Halogen light", which went into production in 1972, one year after the premature death of Joe Colombo, and was therefore named "Colombo" in his honour. The first indoor halogen light to appear on the market, it became an unsurpassed icon of a design that is both functional and contemporary. In the meantime, a new and important era had begun at O luce, coinciding with the transfer of ownership from Ostuni to

the Verderi family, and dominated by one of the great masters of Italian design: Vico Magistretti. For many years, Magistretti was art director and chief designer of the company, conferring his unmistakable stamp and a legacy of worldwide recognition. Kuta, Lester, Nara, Idomeneo, Pascal, Dim, Sonora, Snow, and especially Atollo: all became names that instantly called to mind the corresponding product. "Atollo" even became a sort of template, a graphic silhouette that immediately rendered the concept of a "lamp". "Atollo" - essentially inimitable though copied around the world, winner of the "Compasso d'Oro" in 1979, featured in the permanent collections of all the leading design and decorative arts museums - has thus become much more than just a lamp: it is a legend. Its secret probably lies in the geometry of its forms: the cone on the cylinder, all surmounted by the hemisphere. A luminous sculpture to which nothing can be added, and from which nothing can be taken away. In the meantime, Magistretti's presence protected O luce from superficial forays into post-modernism, as confirmed by the various designs by Bruno Gecchelin included in the catalogue. At the start of the '90s, it was the rigour of the emergent Swiss designer Hannes Wettstein which characterised the company's style. Some examples are Wettstein's "Soirée" model, a slender assembly of aluminium and makrofol, as well as Riccardo Dalisi's ironically provocative "Sister" and "Zefiro" models. Finally, in 1995 O luce took a different tack under the art direction of Marco Romanelli, which bolstered its international success and the collection's critical acclaim. The new formula put the focus on expressing highly diverse personal idioms, and in particular those of leading contemporary designers, such as the Englishman Sebastian Bergne, the Swiss Hans Peter Weidmann, and the Italians Laudani&Romanelli. In 1997 the "Estela" lamp was the world's first industrially-produced object designed by the brothers Fernando and Humberto Campana, poetic narrators of their far-away Brazil. In 2000, the "Nuvola" series marked the start of Toni Cordero's collaboration with O luce. One of the leading Italian architects of his generation, Cordero imposed his vision through the use of utterly disruptive and unconventional forms. Nuvola has been his last, wonderful project.

In 2001 white Murano glass stones and transparent perspex reeds populated the O luce booth at Euro luce. Designed by Laudani&Romanelli and Ferdi Giardini, they proposed a way of doing design that exceeds its function and turns itself into poetry. The search for authoritative international voices that can articulate types of illumination following the O luce philosophy has continued down this path. This small group of designers was then enhanced by the addition of American Tim Power, Finn Harri Koskinen and Italian Carlo Colombo. For O luce, the new millennium opens with new partnerships and new energy. On the one hand it explores territories beyond the confines of light: with "Nerolia", Ferdi Giardini proposes a lamp-fragrance diffuser; "Ibiza" is Francesco Rota's offering of an outdoor device that contains a sophisticated loudspeaker; Laudani & Romanelli have designed a "Cand-led", an artificial candle that can be recharged like a mobile phone, thereby eliminating the need to plug it in; and Harri Koskinen, the young Finn who managed to re-launch Nordic style on the international design stage, in his first attempt beyond his native border, has dreamed up "Lamppu", a reading lamp that features a moveable head that can also be used as a flashlight. Each of these projects follows an important path of research and innovation. In 2005, Japan's most refined young designer, Oki Sato, also known as Nendo, joined the O luce team, first with "Sorane" and then with "Switch". But the desire of O luce to investigate new languages is not yet fulfilled and thus two masters of international design, the Japanese Toshiyuki Kita and the Italian Antonia Astori have recently proposed lamps as absolute items, poetically "out of time" and therefore to rapidly become classics. In a parallel fashion, O luce continues to explore the most diverse, extremist semantic fields, from the sculptural expressionism of the French Emmanuel Babled to the functionalist minimalism of the German Lutz Pankow. But this is no longer the history of oluce, but rather of O luce's contribution to contemporary design.

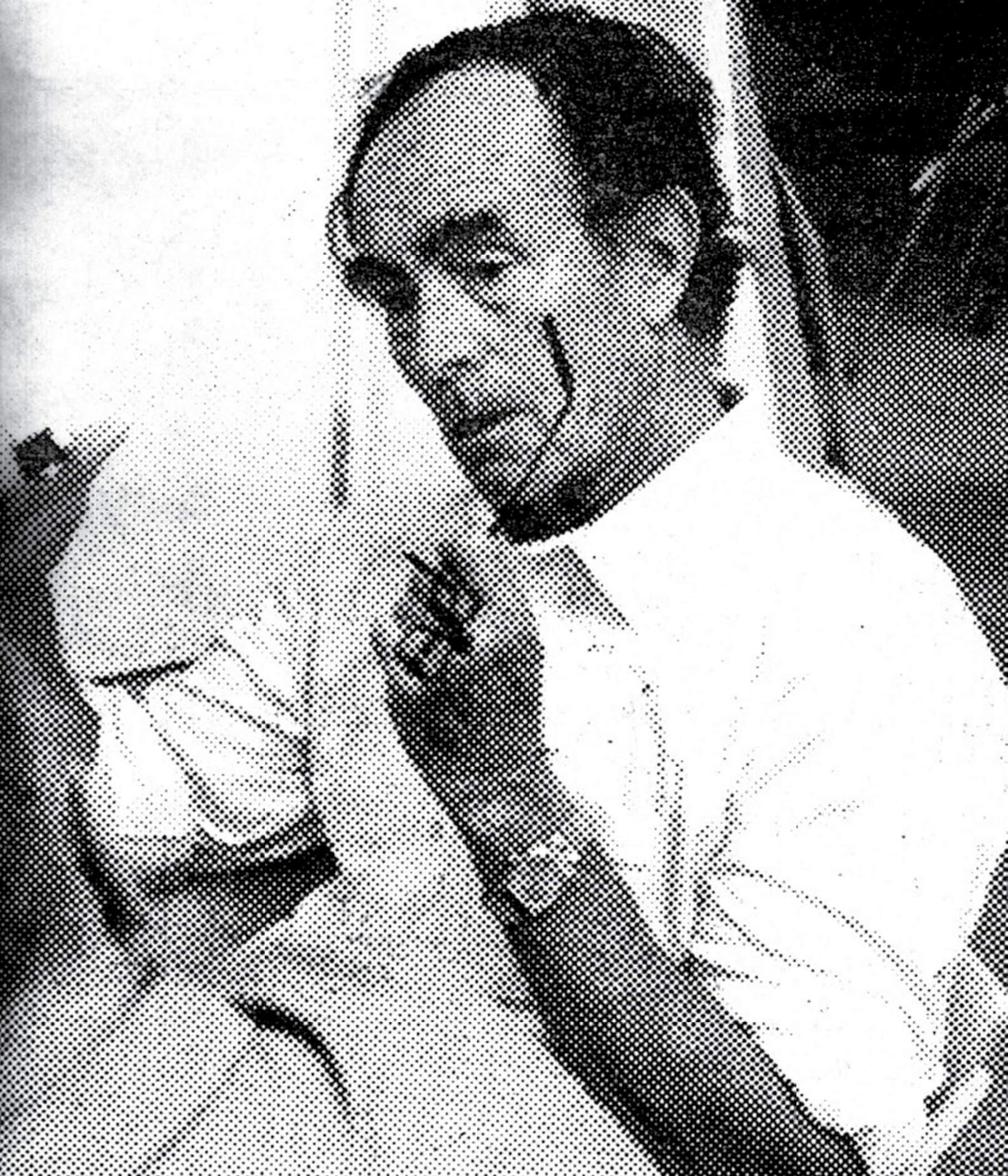

L'histoire

Fondée en 1945 par Giuseppe Ostuni, maître d'art, est, dans le domaine de l'éclairage, la plus ancienne société italienne de design encore en activité. En effet, avant la guerre mondiale, il n'y avait qu'Arteluce de Gino Sarfatti, une société qui a disparu à la fin des années 90. En 1948 Azucena et Lamperti virent le jour, puis, en 1950, Arredoluce et Stilnovo. Cependant, ce seront surtout Arteluce, Azucena et O luce qui joueront, pendant une longue période, les protagonistes sur la scène italienne. Ces sociétés représentèrent des points de rencontre pour ces architectes qui, fortement impliqués d'abord par la reconstruction, puis par la naissance de la production en série, aimaient le débat à Milan : Vittoriano Viganò et les BBPR, Gigi Caccia Dominioni et Ignazio Gardella, Marco Zanuso et Joe Colombo. Déjà en 1951, O luce participait avec succès à la IXe Triennale en présentant, dans la section éclairage dont s'occupaient Achille, Livio et Pier Giacomo Castiglioni, un "luminator" à lumière indirecte incandescente dessiné par Franco Buzzi. Dès le début, comme cela arrivait pendant cette période, la société, grâce à l'intuition de Gio Ponti, conquiert sur la revue Domus la scène internationale. Les catalogues des années 50 confirment la particularité du travail d'Ostuni, un travail qui doit encore être examiné d'un point de vue critique. Un grand succès arrivera avec Tito Agnoli et la mention attribuée à deux de ses lampes lors de la seconde édition du "Compasso d'Oro", en 1955, (le lampadaire mod. 363 et un modèle spécial pour bibliothèque). En 1956 suivront, en rapide succession, deux autres mentions pour une remarquable lampe de table en polyvinyle à lamelles et pour une suspension (mod. 4461) avec double diffuseur en perspex. Il faut encore rappeler, depuis 1954, l'appareil 255/387 (appelé "Agnoli"), fine tige qui soutient un spot, qui marque définitivement la fin des abat-jour et l'adoption de lampadaires très simplifiés y compris pour l'éclairage domestique. En plus d'Agnoli, d'autres designers travaillent avec Ostuni : Forti, interprète oublié des nouvelles exigences d'habitation de la bourgeoisie milanaise, Arnaboldi, Monti et Minale. C'est cependant à la fin de cette décennie, et précisément grâce à la rencontre avec Joe et Gianni Colombo, qu'O luce acquiert une vocation révolutionnaire plus définie. Les frères Colombo (par la suite, seul Joe continuera ses incursions perçantes dans le monde des objets, Gianni s'étant dédié à l'art pur) cherchaient quelqu'un en mesure de répondre à leurs provocations : c'était O luce. La première lampe qui vit le jour fut la lampe de table 281, connue sous le nom d'"Acrilica", présente dans le catalogue O luce depuis 1962. Dessinée comme une courbe en perspex de grande épaisseur où la lumière semble remonter, cette lampe reste, d'un côté, la démonstration d'un point de rencontre possible entre art et design, de l'autre, un témoignage de l'utilisation savante de nouveaux matériaux. Médaille d'or à la XIIIe Triennale, édition où Joe Colombo remportera également deux médailles d'argent (pour le "Combi-Center" et la "Mini-Kitchen"), "Acrilica" désigne la figure de Joe Colombo comme l'un des grands interprètes de cette époque. Entre-temps, Marco Zanuso dessina pour O luce un chef-d'oeuvre oublié, la lampe de table modèle 275, équipée d'un grand diffuseur en perspex blanc orientable par rotation sur un socle en métal laqué blanc, qui fut conçue en 1963 et fabriquée en 1965. Ce fut de nouveau à partir d'un matériau, le verre moulé dénommé "Lentille Fresnel", que, en 1964/66, Joe Colombo conçut la famille de lampes éanches d'extérieur "Fresnel", avec socle en métal verni et diffuseur retenu par des clips en acier. En 1965 suivit le groupe "Spider", où un seul corps d'éclairage, dessiné pour utiliser un spécial spot horizontal, fut monté, grâce à une articulation en mélamine, en différentes situations (maison/bureau) et sur différents supports (table/sol/mur/plafond), en imposant le concept même de "famille" de lampes. La tôle emboutie vernie au feu en blanc, en noir, mais aussi en orange et marron, coulissante sur la tige chromée brillante, parlait du futur. En 1967, elle gagna le premier "Compasso d'Oro" pour O luce et, en 1972, elle fut présentée à New York dans le cadre de l'inoubliable exposition "Italy: the New Domestic Landscape". En 1967, les idées de Colombo sont encore plus avancées et, avec le modèle "Coupé" conservé au MoMA de New York, il propose une tige courbée de grande dimension soutenant une calotte demi-cylindrique particulièrement élégante. Coupé remporte, en 1968, l'"International Design Award" de l'American Institute of Interior Designers de Chicago. Enfin en 1970, pour entrer en production en 1972, un an après la mort prématurée de Joe Colombo, naît "Lampe halogène" qui depuis lors est, nécessairement, appelée "Colombo". Première lampe halogène pour intérieur à apparaître sur le marché, elle demeure une icône inégalée d'un design à la fois fonctionnel et contemporain.

A cette époque, O luce débute une nouvelle et très importante saison coïncidant avec le passage de la propriété d'Ostuni à la famille Verderi: une saison dominée par la figure prépondérante de l'un des grands maîtres du design italien, Vico Magistretti. Pendant de longues années, Magistretti sera art director et principal designer de la compagnie, en imposant son style unique et en consolidant une image connue dans le monde entier. Kuta, Lester, Nara, Idomeneo, Pascal, Dim, Sonora, Snow, mais surtout Atollo, deviennent des noms capables, à eux seuls, d'évoquer le produit correspondant. "Atollo" se transforme même en une forme, une silhouette graphique en mesure de représenter le concept "lampe". "Atollo", imitée dans le monde entier mais, au fond, inimitable, qui a gagné le "Compasso d'Oro" en 1979, présente dans toutes les collections permanentes des musées de design et art décoratifs les plus importants, est donc beaucoup plus qu'une lampe. C'est un mythe. Son secret réside probablement dans la construction géométrique des formes : le cône sur le cylindre et, sur le tout, l'hémisphère. Une sculpture lumineuse à laquelle on ne peut rien enlever, à laquelle on ne peut rien ajouter. La présence de Magistretti préserve O luce contre les faciles incursions dans les poétiques post-modernistes, comme cela est démontré par la présence parallèle dans le catalogue de nombreuses pièces de Bruno Gecchelin. Au début des années 90, ce fut la rigueur du suisse Hannes Wettstein, alors designer prometteur, qui caractérisa la poétique de la société. Nous rappelons, de Wettstein, le modèle "Soirée", assemblage aérien d'aluminium et makrofol, puis les provocations ironiques de Riccardo Dalisi avec les modèles Sister et Zefiro. Enfin, en 1995, O luce entreprend un nouveau cours qui, sous la direction artistique de Marco Romanelli, agrandit encore le succès international et l'appréciation critique de la collection. La nouvelle formule est axée sur la valorisation de langages très divergents et personnels, appartenant en particulier à des personnalités de premier rang de la recherche contemporaine comme l'anglais Sebastian Bergne, le suisse Hans Peter Weidmann, les italiens Laudani&Romanelli. En 1997, la lampe "Estela" est le premier objet des frères Fernando et Humberto Campana, interprètes poétiques de leur lointain Brésil, pour lequel est lancée une production industrielle. En l'an 2000, avec la série "Nuvola", débute la collaboration entre O luce et Toni Cordero. Celui-ci, qui est l'un des architectes italiens les plus importants de sa génération, s'impose pour ses formes éclatantes et non homologuées. Nuvola a été son dernier et merveilleux projet. En 2001 galets blancs en verre de Murano et cannes en perspex transparent peuplaient le stand O luce à EuroLuce. Conçus par Laudani&Romanelli et Ferdi Giardini, ceux-ci proposent une manière de faire design qui surpasse la fonction pour devenir poésie. Les recherches dans cette direction se poursuivent grâce à des voix influentes au niveau international qui peuvent décliner les typologies de l'éclairage conformément à la philosophie de O luce. Le groupe compact de concepteurs s'enrichit désormais en englobant l'américain Tim Power, le finlandais Harri Koskinen et l'italien Carlo Colombo. Un nouveau millénaire commence pour O luce, fait de nouvelles collaborations et d'une énergie nouvelle. D'une part, c'est une exploration de territoires situés aux frontières de la lumière : avec "Nerolia", Ferdi Giardini propose un luminaire qui diffuse des essences parfumées; Francesco Rota, avec "Ibiza", un appareil d'extérieur qui contient un haut-parleur sophistiqué; Laudani&Romanelli, avec "Cand-led", une bougie lumineuse libre des contraintes de l'alimentation électrique, rechargeable comme un téléphone portable. Quant à Harri Koskinen, le jeune Finlandais qui est parvenu à relancer le design nordique sur la scène internationale, à sa première expérience à l'extérieur de ses frontières nationales, il a imaginé "Lamppu", une lampe de lecture à tête amovible qui peut être utilisée comme lampe torche. Chacun de ces projets inaugure un précieux filon de recherche et d'innovation. En 2005, avec "Sorane" d'abord et puis "Switch", c'est le plus raffiné des nouveaux concepteurs japonais, Oki Sato, mieux connu comme Nendo, qui entre dans l'équipe O luce. Mais la volonté d'O luce d'exploiter de nouveaux langages n'est pas encore assouvie et c'est pourquoi deux maîtres du design international tels que le japonais Toshiyuki Kita et l'italienne Antonia Astori ont récemment proposé des lampes comme des pièces absolues, poétiquement «hors du temps» et donc vouées à se transformer très rapidement en grands classiques. O luce continue parallèlement à enquêter sur les champs sémantiques les plus différents et les plus extrémistes, de l'expressionnisme sculptural du français Emmanuel Babled au minimaliste fonctionnaliste de l'allemand Lutz Pankow. Mais cela n'est plus l'histoire d'O luce, il s'agit plutôt de la contribution d'O luce au design contemporain.

Die Geschichte

Die 1945 vom hervorragenden Meister Giuseppe Ostuni gegründete Firma O luce ist im Beleuchtungsbereich die älteste noch im Betrieb stehende Designfirma in Italien. Vor dem zweiten Weltkrieg bestand nämlich nur die Firma Arteluce von Gino Sarfatti, die am Ende der neunziger Jahre einging. 1948 wurden dann Azucena und Lamperti und 1950 Arredoluce und Stilnovo gegründet. Es waren jedoch vor allem Arteluce, Azucena und O luce, welche während langen Jahren das italienische Panorama bestimmten und der Treffpunkt für jene Designer darstellten, welche, tief in den Wiederaufbau der ersten Zeit und nachher in die aufkommende Serienherstellung verwickelt, die öffentliche Diskussion in Mailand bestimmten: Vittoriano Viganò und die BBPR, Gigi Caccia Dominioni und Ignazio Gardella, Marco Zanuso und dann Joe Colombo. Schon 1951 nimmt O luce erfolgreich an der 9. Triennale-Ausstellung teil, in dem sie im Beleuchtungssektor, der von Achille, Livio und Pier Giacomo Castiglioni arrangiert wurde, eine von Franco Buzzi entworfene Leuchte mit indirektem Glühlicht vorstellen. Der Betrieb wird sofort, wie es in der damaligen Zeit war, durch das Fingerspitzengefühl von Gio Ponti und durch die Gründung der Zeitschrift Domus eine internationale Schule. Die Kataloge der fünfziger Jahre bestätigen die Einzigartigkeit der Arbeit von Ostuni, die im Grunde immer noch kritisch zu untersuchen ist. Großen Erfolg erlangte Tito Agnoli 1955 bei der zweiten Preisvergabe des Compasso d'Oro mit den Auszeichnungen zweier Leuchten von ihm (eine Stehleuchte ART. 363 und ein Spezialmodell für Büchergestelle). 1956 folgten Zug um Zug zwei weitere Auszeichnungen für eine äußerst nennenswerte Tischleuchte aus Polyvinylamellen und für eine Hängeleuchte (Mod.4461) mit zweifachem Leuchtkörper aus Perspex. Schließlich ist es äußerst wichtig daran zu erinnern, dass seit 1954 die Leuchte 255/387 ("Agnoli" genannt), ein dünner Stab, der einen Direktstrahler trägt, definitiv das Ende der Lampenschirme und die Einführung von sehr einfachen Stehleuchten auch in die Hausbeleuchtung ankündigt. Neben Agnoli arbeiten auch Forti, der vergessene Interpret der neuen Wohnbedürfnisse der Mailänder, Arnaboldi, Monti und Minale mit Ostuni zusammen. Aber am Ende des Jahrzehntes und zwar dank der Begegnung mit Joe und Gianni Colombo kommt es dazu, dass O luce einen deutlicheren revolutionären Aufschwung nimmt. Die Brüder Colombo (später dann führt nur noch Joe seine gewagten Einfälle in der Welt der Kunstgegenstände weiter, während sich Gianni der reinen Kunst widmet) suchten jemanden, der in der Lage war, auf ihre Provokationen zu reagieren. Als erstes entstand die unter dem Namen "Acrilica" bekannte Tischleuchte 281, die seit 1962 im Katalog von O luce verzeichnet ist. Aus lang gebogenem dickem Perspex bestehend, längs dessen das Licht aufzusteigen scheint, ist diese Leuchte einerseits der Beweis eines möglichen Berührungspunkts von Kunst und Design, andererseits zeugt sie vom geistreichen Einsatz der neuen Kunststoffe. Die Goldmedaille an der 13. Triennale-Ausstellung, dieselbe, bei der Joe Colombo auch zwei Silbermedaillen (für den "Combi-Center" und die "Mini-Kitchen") erhält, reiht Joe Colombo unter die großen Zeitinterpreten. Indessen entwirft Marco Zanuso 1963 für O luce ein Meisterwerk, das von 1965 an in Produktion gegeben wurde und inzwischen in Vergessenheit geraten ist, nämlich die Tischleuchte Modell 275 mit großem schwenkbarem Diffusor aus weißem Perspex, die auf einer weiß lackierten Grundplatte befestigt ist. Ebenfalls ausgehend von einem Material, das "Lente Fresnel" genannte Gussglas, entsteht 1964/66 in Zusammenarbeit mit Joe Colombo die Familie der wetterdichten Gartenleuchten "Fresnel", bestehend aus einer lackierten Metallgrundplatte und einem mit Stahlklammern festgehaltenen Diffusor. 1965 folgt die "Spider"-Gruppe, bei der ein einziger Leuchtkörper, der auf die Nachfrage nach einem speziellen horizontalen Direktstrahler hin entworfen wurde, mittels eines Melamingelenks in verschiedene Räumlichkeiten (Haus/Büro) und auf verschiedene Unterlagen (Tisch/Boden/Wand/Decke) montiert wurde, und die gerade dadurch den Begriff der "Lampenfamilie" schuf. Die gestanzte Blechleuchte, die weiß, schwarz, aber auch orange und braun einbrennlackiert wird und längs dem glänzend verchromten Stab verstellbar ist, war zukunftsweisend. 1967 gewann sie den ersten Compasso d'Oro-Preis für die Firma O luce und 1972 war sie in New York anlässlich der unvergesslichen Ausstellung "Italy: the New Domestic Landscape". 1967 ist Colombo jedoch bereits weiter fortgeschritten und mit dem Modell "Coupé", das im MoMA in New York aufbewahrt ist, schlägt er einen gebogenen Lampenstiel von beträchtlicher Länge vor, der eine äußerst elegante halbzylindrische Kappe stützt. Die Coupé-Leuchte gewinnt 1968 den "International Design Award" des American Institute of Interior Designers in Chicago. 1970 dann entsteht die "Halogenleuchte", die 1972, ein Jahr nach dem frühzeitigen Tod von Joe Colombo, in Produktion gegeben wird und seither folglich "Colombo" genannt wird. Dies ist die erste Halogenleuchte für die Inneneinrichtung, die auf dem Markt erscheint, ein unübertreffliches Sinnbild eines zweckmäßigen wie auch zeitgenössischen Designs. Inzwischen tritt jedoch O luce in eine neue

sehr wichtige Epoche, welche mit dem Eigentumsübergang von Ostuni zur Familie Verderi zusammenfällt und durch die vorherrschende Gestalt eines großen Meisters des italienischen Designs gekennzeichnet ist: Vico Magistretti. Während langen Jahren ist Magistretti Art Director und wichtigster Designer der Firma, wobei er bei ihr eine unverkennbare Spur und einen charakteristischen Stil hinterläßt, der eine weltweite Verbreitung gefunden hat. Kuta, Lester, Nara, Idomeneo, Pascal, Dim, Sonora, Snow und vor allem Atollo werden zu Begriffen, welche sich automatisch mit dem entsprechenden Produkt identifizieren. Atollo verwandelt sich sogar in ein Profil, eine grafische Silhouette, die von selbst den Begriff "Lampe" wiedergibt. Die weltweit nachgeahmte aber im Grunde unnachahmliche Atollo, 1979 Siegerin des "Compasso d'Oro"-Preises und in allen Dauerausstellungen der größten Design- und Art-déco-Museen vorhanden, ist so nun mehr viel mehr als eine Lampe. Sie ist ein Mythos. Ihr Geheimnis liegt wahrscheinlich im geometrischen Aufbau der Formen: der auf den Zylinder gesetzte Kegel und darauf die Halbkugel. Eine leuchtende Skulptur, an der nichts weggelassen oder hinzugefügt werden kann. Die Anwesenheit Magistrettis indessen bewahrt O luce vor leichten Einfällen in die postmodernen Stilrichtungen, was die gleichzeitigen zahlreichen im Katalog vorhandenen Stücke von Bruno Gecchelin beweisen. Zu Beginn der neunziger Jahre ist es die Strenge des damals ins Rampenlicht tretenden Schweizer Hannes Wettstein, die den Firmenstil bestimmt. Gerade von diesem Wettstein soll das Modell "Soirée", eine dünne Struktur aus Aluminium und Makrofol, erwähnt werden und ebenso die ironischen Provokationen von Riccardo Dalisi mit den Modellen Sister und Zefiro, 1995 dann schlägt O luce einen neuen Kurs ein, der mittels der Art Direction von Marco Romanelli den internationalen Erfolg und die Anerkennung der Sammlung seitens der Kritiker steigert. Die neue Formel geht von der Aufwertung von äußerst unterschiedlichen und persönlichen Stilen aus, welche zu den wichtigsten Vertretern der zeitgenössischen Kunstrichtungen gehören wie der Engländer Sebastian Bergne, der Schweizer Hans Peter Weidmann und die Italiener Laudani/Romanelli. Die Leuchte "Estela" ist im Jahre 1997 der erste industriell hergestellte Kunstgegenstand der Welt und dies dank der Brüder Fernando und Humberto Campana, poetische Interpreten ihres fernen Brasiliens. Im Jahr 2000 beginnt Toni Cordero mit der Serie "Nuvola" mit O luce zusammenzuarbeiten. Cordero behauptet sich unter den bedeutendsten italienischen Architekten seiner Generation durch seine hervorstechenden und untraditionellen Formen. Nuvola ist sein letztes Projekt gewesen. Im Jahr 2001 beleben steine aus weissem Muranoglass und röhricht aus transparentem Perspex den stand der Firma O luce bei EuroLuce. Nach einem entwurf von Laudani&Romanelli und Ferdi Giardini wird eine art und weise des designs angeboten, das die funktionalität überschreitet, um zur poesie zu werden. Diesem weg folgt die suche nach namhaften internationalen stimmen, die die arten der beleuchtung nach der philosophie von oluce abwandeln. Die kompakte gruppe von projektanten wird nun durch aufnahme des amerikaners Tim Power, des finnen Harri Koskinen und des italieners Carlo Colombo bereichert. Für Oluce beginnt das neue Jahrtausend mit neuen Kooperationen und einer neuen Energie. Auf der einen Seite werden Gebiete an den Grenzen des Lichts erforscht: Ferdi Giardini präsentiert mit Nerolia eine Lampe, mit der Duftessenz zerstäubt werden, Francesco Rota mit Ibiza ein im Freien zu benutzendes Gerät mit eingebautem Lautsprecher, Laudani&Romanelli mit Cand-led eine kerzenförmige Tischlampe, die keine Steckdose benötigt und sich wie ein Mobiltelefon aufladen lässt. Der junge Finne Harri Koskinen, der das nordische Design wieder auf der internationalen Szene aufleben lässt und zum ersten Mal eines seiner Produkte außerhalb der nationalen Grenzen präsentiert, stellt sich mit Lamppu eine Leselampe vor, deren Kopf entfernt und als Taschenlampe verwendet werden kann. Jedes dieser Projekte liefert seinen Beitrag zu einer wertvollen Forschungs- und Innovationslinie. Zum Oluce- Team gehört auch Oki Sato, auch Nendo genannt, der raffinierteste unter den neuen japanischen Designern, der zuerst Sorane und dann Switch vorstellt. Aber der Wunsch von O luce, neue Ausdrucksformen zu erkunden, ist noch nicht befriedigt und so haben zwei Meister des internationalen Designs wie der Japaner Toshiyuki Kita und die Italienerin Antonia Astori kürzlich Lampen als absolute Stücke vorgestellt, die poetisch "zeitlos" und daher dazu bestimmt sind, sich schnell in Klassiker zu verwandeln. Gleichzeitig erforscht O luce weiter die unterschiedlichsten und extremistischsten Bedeutungsfelder, vom bildhauerischen Expressionismus des Franzosen Emmanuel Babled bis zum funktionalistischen Minimalismus des Deutschen Lutz Pankow. Aber dies gehört nicht mehr zur Geschichte von O luce, sondern es handelt sich eher um den Beitrag der Firma O luce zum zeitgenössischen Design.



Come può configurarsi oggi un catalogo di lampade?

Se il produttore è, come O luce, uno dei nomi storici del design italiano, un catalogo può vivere solamente così: nutrendosi della tradizione e dell'esperienza per procedere verso nuove definizioni. D'altronde il progetto italiano, quello migliore, si è sempre sviluppato secondo tale logica: costantemente teso a superare se stesso, costantemente supportato da una straordinaria organizzazione d'impresa, da un raffinato patrimonio tecnologico e soprattutto dall'indomita passione di ciascuno per il proprio lavoro.

Se O luce, all'inizio degli anni '60, aveva ospitato il giovane Joe Colombo producendo una serie di pezzi tuttora a catalogo, tuttora inimitabili, se O luce, agli inizi degli anni '70, aveva ospitato il giovane Vico Magistretti, rapidamente divenuto uno dei grandi maestri, dalla fine degli anni '90 O luce si è dimostrata capace di aprire le porte a nuovi progettisti, italiani ed europei, che intensamente testimoniassero delle più recenti tendenze. Ognuno di loro, supportato dalla nostra esperienza, è stato completamente libero di esprimersi secondo il suo linguaggio. Il progetto d'azienda e il know-how tecnico sono stati infatti sufficienti, nel rispetto delle differenze, a creare una precisa e comune identità. Ecco dunque che alle geometrie assolute di Vico Magistretti, alla modernità ormai classica di Joe Colombo, alla discrezione di Tito Agnoli vengono ad aggiungersi il minimalismo poetico di Toshiyuki Kita e Laudani&Romanelli, la dirompente energia di Emmanuel Babled, le parole asciutte di Gordon Guillaumier, Carlo Colombo e Lutz Pankow, le ricerche espressive di Francesco Rota, Ferdi Giardini e Paolo Imperatori, l'eleganza stringata di Astori/De Ponti e di Nendo.

What can a catalogue of lamps look like today?

If the manufacturer, as is the case of O luce, is one of the historic names of Italian design, a catalogue can only live like this: nurtured on tradition and experience so as to move on towards new definitions. Moreover, Italian design, the best of it, has always developed along these lines, constantly endeavouring to surpass itself and constantly supported by an extraordinary business organisation, by a refined technological wealth and above all by each and every person's unflinching passion for his work. In the early nineteen-sixties O luce had played host to the young Joe Colombo and has produced a range of items that are still in its catalogue; in the early nineteen-seventies O luce had played host to the young Vico Magistretti, who soon became one of the great masters. Now, starting in the late nineteen-nineties, O luce has also proved capable of opening its doors to new Italian and European designers so that they could bear witness with strength to the most recent trends. Each of them, with our experience behind them, has been left entirely free to express himself in his own specific language. Indeed, the corporate project and technical know-how were sufficient to create, albeit with due regard for their differences, to create a precise and common identity. Thus, the absolute geometries of Vico Magistretti, the now classical modernity of Joe Colombo, the discretion of Tito Agnoli, have been joined by the poetic minimalism of Toshiyuki Kita and of Laudani&Romanelli, the disruptive energy of Emmanuel Babled, the dry words of Gordon Guillaumier, Carlo Colombo and Lutz Pankow, the expressive research of Francesco Rota, Ferdi Giardini and Paolo Imperatori, and the concise elegance of Astori/De Ponti and of Nendo.

Comment organiser aujourd'hui un catalogue de lampes?

Si le producteur est, comme O luce, l'un des noms historiques du design italien, un catalogue peut se développer tout simplement en s'inspirant de la tradition et de l'expérience pour procéder enfin vers de nouvelles définitions. D'autre part, le projet italien le meilleur s'est toujours développé en suivant cette logique: une recherche constante pour s'améliorer, toujours soutenue par une extraordinaire organisation d'entreprise, par un patrimoine technologique raffiné et surtout par la farouche passion de chacun pour son travail.

O luce qui, au début des années 60, avait accueilli le jeune Joe Colombo en produisant une série de pièces encore aujourd'hui en catalogue et encore aujourd'hui inimitables, et, au début des années 70, avait accueilli le jeune Vico Magistretti, rapidement élevé au rang des grands maîtres, s'est avéré, à partir de la fin des années 90, en mesure d'ouvrir également les portes à de nouveaux designers, italiens et européens, capables de donner une marque significative des tendances les plus récentes. Chacun d'entre eux, épaulé par notre expérience, a été complètement libre d'exprimer son langage personnel. En effet, la structure de la société et le savoir-faire technique ont suffi pour créer, dans le respect des différences, une identité précise et commune. C'est ainsi qu'aux géométries absolues de Vico Magistretti, à la modernité désormais classique de Joe Colombo, à la discrétion de Tito Agnoli, ce sont ajoutés le minimalisme poétique de Toshiyuki Kita et Laudani&Romanelli, l'énergie explosive de Emmanuel Babled, le langage concis de Gordon Guillaumier, Carlo Colombo et Lutz Pankow, les recherches expressives de Francesco Rota, Ferdi Giardini et Paolo Imperatori, l'élégance essentielle de Astori/De Ponti et Nendo.

Wie kann heute ein Lampenkatalog aussehen?

Wenn es sich um einen Hersteller wie O luce handelt, einer der historischen Namen in der Geschichte des italienischen Designs, dann kann ein Katalog nur so leben: indem man sich auf die Tradition und Erfahrung bezieht, um neue Definitionen festzulegen. Im Übrigen hat sich die beste italienische Entwurfsarbeit immer nach dieser Überlegung entwickelt: so ist sie ständig darauf bedacht, sich selbst zu übertreffen, ist fortwährend von einer hervorragenden Betriebsorganisation, einem hochentwickelten Technologiebestand und vor allem von der ungestümen Leidenschaft eines jeden für seine Arbeit unterstützt. Wenn O luce zu Beginn der 60er Jahre den jungen Joe Colombo bei sich als Entwerfer hatte und dabei eine Reihe von noch heute im Katalog aufgeführten unnachahmlichen Artikeln hergestellt hatte, wenn O luce zu Beginn der 70er Jahre den jungen Vico Magistretti bei sich hatte, der innerhalb kurzer Zeit einer der großen Meister wurde, so erwies sich O luce seit Ende der 90er Jahre fähig, ebenfalls neue italienische und europäische Designer bei sich aufzunehmen, welche nachhaltig von den neusten Trends zeugen sollen. Jeder von ihnen war, unter Beihilfe unserer Erfahrungen, ganz frei, sich nach seinem eigenen Stil auszudrücken. Der Betriebsplan und das technische Know-how waren nämlich ausreichend, um bei aller Achtung der Unterschiede eine genau bestimmte gemeinsame Identität zu schaffen. So kommt es, dass zu Vico Magistrettis absoluten geometrischen Formen, zu Joe Colombos nun mehr klassischen Moderne, zu Tito Agnolis Diskretion der poetische Minimalismus von Toshiyuki Kita und Marta Laudani/Marco Romanelli, die sprühende Energie Emmanuel Bableds; Gordon Guillaumiers, Carlo Colombos und Lutz Pankows trockene Worte, Ferdi Giardinis, Francesco Rotas und Paolo Imperatoris. Suche nach neuen Ausdrucksformen, Astori/De Pontis und Nendos straffer Eleganz hinzukommen.

Index

Lampade da tavolo	Table lamps	Lampes de table	Tischleuchten	Atollopag. 16_21
				Spider22_23
				Colombo 24_25
				Flash 26_27
				Coupé 28_29
				Denq 30_31
				Arezzo 32_35
				Lu-Lu 36_39
				Pin stripe 40_41
				Stone of glass 42_45
				Nerolia 46_47
				Cand-Led 48_49
				Switch 50_53
				Lutz 54_57
Lampade da Terra	Floor lamps	Lampadaires	Stehleuchten	Coupépag. 60_67
				Spider 68_69
				Agnoli 70_71
				Sher 72_73
				Lu-Lu 74_75
				Teda 76_77
				Sherwood 78_81
				Switch 82_83
				Do with 84_87
				Beth 88_89
				Pascal 90_91
				Colombo 92_97
				Dim 98_101
Parete Soffitto	Wall/Ceiling lamps	Appliques/Plafonniers	Wand/Deckenleuchten	Fiorepag. 104_105
				Pin Stripe 106_107
				Diamond 108_109
				Drop110_111
				Alias112_113
				Line114_117
				JK118_119
				Kelly120_121
				Sixty122_123
				“1960”124_127
				Diamante 128_131
				Tessera 132_135
				Line136_137
				Universal 138_143
				Colombo 144_147
				Fresnel148_149
Lampade a sospensione	Suspension lamps	Lampes à suspension	Hängeleuchten	Sonorapag. 152_159
				Plateau 160_163
				Coroa 164_165
				Circles 166_169
				Canopy 170_173
				Drop174_175
				Pin Stripe 176_177
				Piazza San Marco 178_179
				Fiore 180_183
				Lanterna184_187
				Colombo188_191
				Line192_197
Lampade da esterno	Outside lamps	Lampes pour l'extérieur	Außen beleuchtung	Stonespag. 200_201
				Lyndon202_207
				Fresnel208_211
				Pil-low212_215
				Ela216_219
				“1960” 220_221
				Diamante222_225
				Teda 226_231

Lampade da tavolo



Table lamps Lampes de table Tischleuchten





ATOLLO Vico Magistretti 1977

ATOLLO 233

Lampada da tavolo a luce diretta
in alluminio verniciato, con dimmer.

Table lamp in lacquered aluminium
giving direct light, with dimmer.

Lampe de table en aluminium verni
à lumière directe, avec dimmer.

Tischleuchte aus lackiertem Aluminium
mit direktem Licht, mit Dimmer.

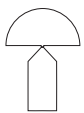

tavolo table	terra floor	parete_soffitto wall_ceiling	sospensione suspension	esterno outdoor

dati tecnici_technical data p. 236





ATOLLO Vico Magistretti 1977

ATOLLO 235, 236, 237

Lampada da tavolo a luce diretta e diffusa in vetro di Murano opalino. Con dimmer (235, 237).

Table lamp giving direct and diffused light in opaline blown Murano glass diffuser. With dimmer (235, 237).

Lampe de table à lumière directe et diffuse en verre soufflé de Murano opalin. Avec dimmer (235, 237).

Tischleuchte mit direktem und diffusem Licht aus opal geblasenem Murano Glas. Mit Dimmer (235, 237).

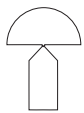

tavolo table	terra floor	parete_soffitto wall_ceiling	sospensione suspension	esterno outdoor

dati tecnici_technical data p. 236









oluce

SPIDER Joe Colombo 1965

SPIDER 291

Lampada da tavolo a luce diretta, base in metallo verniciato, asta cromata; riflettore, orientabile e regolabile, in alluminio verniciato.

Table lamp giving direct light, lacquered metal base, chromium-plated stem, adjustable reflector in lacquered aluminium.

Lampe de table à lumière directe, base en métal verni, tige chromée, réflecteur orientable et réglable en aluminium verni.

Tischleuchte mit direktem Licht, Sockel aus lackiertem Metall, drehbarer und verstellbarer Reflektor aus lackiertem Aluminium.

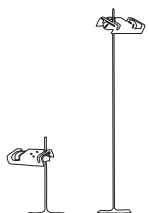

tavolo table	terra floor	parete_soffitto wall_ceiling	sospensione suspension	esterno outdoor
-----------------	----------------	---------------------------------	---------------------------	--------------------

p. 69

dati tecnici_technical data p. 256





COLOMBO 281

Lampada da tavolo a luce indiretta e diffusa, base in acciaio verniciato e diffusore in Perspex.

Table lamp giving indirect and diffused light, laquered steel base and Perspex diffuser.

Lampe de table à lumière indirecte et diffuse, base en acier verni et diffuseur en Perspex.

Tischleuchte mit indirektem und diffusem Licht, Sockel aus lackiertem Stahl und Leuchtkörper aus Perspex.



tavolo table	terra floor	parete_soffitto wall_ceiling	sospensione suspension	esterno outdoor

dati tecnici_technical data p. 237



FLASH Joe Colombo 1968

FLASH 2207

Lampada da tavolo a luce diretta e riflessa. Riflettore in alluminio verniciato e base in metallo verniciato. Accensione con dimmer.

Table lamp giving direct and reflected light. Reflector in lacquered aluminium and base in lacquered metal. With dimmer.

Lampe de table à lumière directe et réfléchie. Réflecteur en aluminium verni et base en métal verni. Allumage avec variateur.

Tischleuchte mit direktem und reflektiertem Licht. Reflektor aus lackiertem Aluminium und Fuß aus lackiertem Metall. Einschaltung mit Dimmer.



tavolo table	terra floor	parete_soffitto wall_ceiling	sospensione suspension	esterno outdoor

dati tecnici_technical data p. 256





COUPE Joe Colombo 1967

COUPE 2202

Lampada da tavolo a luce diretta, base in metallo verniciato, asta cromata; riflettore, orientabile e regolabile, in alluminio verniciato.

Table lamp giving direct light, lacquered metal base, chromium-plated stem, adjustable reflector in lacquered aluminium.

Lampe de table à lumière directe, base en métal verni, tige chromée, réflecteur orientable et réglable en aluminium verni.

Tischleuchte mit direktem Licht, Fuß aus lackiertem Metall, verchromter Stab, drehbarer und verstellbarer Reflektor aus lackiertem Aluminium.

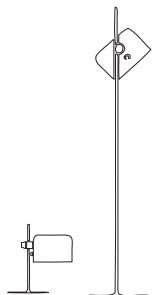

tavolo table	terra floor	parete_soffitto wall_ceiling	sospensione suspension	esterno outdoor
p. 65				
dati tecnici_technical data p. 256				





DENQ 229

Lampada da tavolo a luce diffusa in vetro soffiato opalino acidato. Base in metallo verniciato con disco sovrabase in metallo tagliato al laser e cromato. Accensione con dimmer.

Table lamp giving diffused light in opaline opaque blown glass. Lacquered metal base with chromium-plated laser cut upper base disc. With dimmer switch.

Lampe de table à éclairage diffus en verre soufflé, opalin, acidifié. Base de métal laqué avec disque de métal en surbase coupé au laser et chromé. Allumage avec variateur d'intensité lumineuse.

Tischleuchte mit diffusem Licht aus säurebehandeltem, geblasenem Opalglas. Fuß aus lackiertem Metall mit Auflagescheibe aus verchromten, laserbearbeitetem Metall. Helligkeitssteuerung mit Dimmer.



tavolo table	terra floor	parete_soffitto wall_ceiling	sospensione suspension	esterno outdoor
-----------------	----------------	---------------------------------	---------------------------	--------------------

dati tecnici_technical data p. 242



AREZZO 227

Lampada da tavolo a luce diffusa in vetro soffiato opalino lucido. Lente superiore in vetro diffusore curvato. Base in metallo verniciato. Accensione con dimmer.

Table lamp giving diffused light, in glossy opaline blown glass. Upside lens in curved glass diffuser. Lacquered metal base. With dimmer switch.

Lampe de table à éclairage diffus en verre soufflé opalin poli. Verre supérieur en diffuseur courbe. Base de métal laqué. Allumage avec variateur d'intensité lumineuse.

Tischleuchte mit diffusem Licht aus glänzendem, geblasenem Opalglas. Obere Linse aus gekrümmtem Diffusionsglas. Helligkeitssteuerung mit Dimmer.



tavolo table	terra floor	parete_soffitto wall_ceiling	sospensione suspension	esterno outdoor

dati tecnici_technical data p. 258







LU-LU Stefano Casciani 1996

LU-LU 211

Lampada da tavolo. Diffusore in vetro di Murano. Base in metallo spazzolato. Doppia accensione con dimmer.

Table lamp. Murano glass diffuser. Brushed metal base. Double lighting with dimmer.

Lampe de table. Diffuseur en verre de Murano. Base en métal brossé. Double allumage avec dimmer.

Tischleuchte. Streukörper aus Murano Glas. Fuß aus aufgerauhtem Metall. Doppelte Anzündung mit Dimmer.

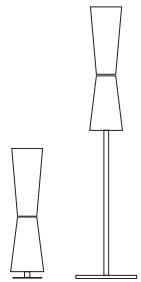

tavolo table	terra floor	parete_soffitto wall_ceiling	sospensione suspension	esterno outdoor
	p. 75			
dati tecnici_technical data p. 240				





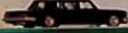



PIN STRIPE 217

Lampada da tavolo a luce diffusa in vetro trasparente decorato. Base e struttura in metallo verniciato. Accensione con dimmer.

Table lamp giving diffused light in transparent glass decorated. Base and structure in painted metal. Lighting with dimmer.

Lampe de table à éclairage diffus en verre transparent décoré. Base et structure en métal peint. Allumage avec commande d'intensité d'éclairage.

Tischleuchte mit diffusem Licht aus verziertem, durchsichtigem Glas. Fuß und Struktur aus lackiertem Metall. Einschaltung mit Dimmer.

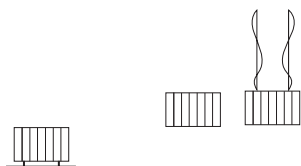

tavolo table	terra floor	parete_soffitto wall_ceiling	sospensione suspension	esterno outdoor
		p. 107	p. 177	
dati tecnici_technical data p. 241				



STONE OF GLASS Laudani&Romanelli 2001

STONE OF GLASS



202, 203, 204

Lampada da appoggio a luce diffusa
in vetro opalino acidato di Murano.

Lamp to be placed giving diffused light
in opaline opaque Murano glass diffuser.

Lampe à poser à lumière diffuse
en verre opalin acidé de Murano.

Legleuchte mit diffusem Licht, aus
Azidierten-opal Murano Glas.

	
tavolo table	terra floor
parete_soffitto wall_ceiling	sospensione suspension
	esterno outdoor
p. 201	
dati tecnici_technical data p. 242	









NEROLIA Ferdi Giardini 2001

NEROLIA 209

Lampada da tavolo a luce diffusa,
in vetro cristallo trasparente.
Contenitore per acqua ed essenza
aromatica e paraluce in vetro ambra.
Accensione con dimmer.

Table lamp, giving diffused light, made
of transparent crystal. Container
for water and aroma-terapic essence
and light-shade in amber glass.
With dimmer.

Lampe de table à lumière diffuse,
en cristal transparent. Bac pour eau
et essences aromatiques et diffuseur
en verre couleur ambre. Allumage
avec variateur.

Tischleuchte mit bestrahlenden Licht,
aus durchsehenden Kristallglas.
Behälter fuer Wasser und Aromatische
Exenz und Schutzlicht aus Amber Glas.
Einschaltung mit Dimmer.



tavolo table	terra floor	parete_soffitto wall_ceiling	sospensione suspension	esterno outdoor

dati tecnici_technical data p. 240





CAND-LED 205

Lampada da tavolo a luce diffusa con LED. Diffusore in PMMA trasparente. Copribase in alluminio satinato e anodizzato. Dotata di batterie ricaricabili per l'utilizzo senza il collegamento alla rete. Carica batterie esterno e filtri colorati.

Table lamp giving diffused light, with LED. Lampshade in transparent PMMA. Satin anodised aluminium base-cover. Supplied with re-chargeable batteries for use without connection to the mains. With battery charger and coloured plastic filters.

Lampe de table à lumière diffuse avec LED. Diffuseur en PMMA transparent. Couvre base en aluminium satiné et anodisé. Equipée de piles rechargeables pour une utilisation sans raccordement au réseau. Chargeur de batterie externe et de filtres colorés en plastique.

Tischlampe mit gestreutem Licht mit LED. Leuchtkörper aus transparentem PMMA. Basisabdeckung aus satiniertem und eloxiertem Aluminium. Ausgestattet mit aufladbaren Batterien ohne Netzverbindung, Batterieladegerät und gefärbten Plastikfiltern.

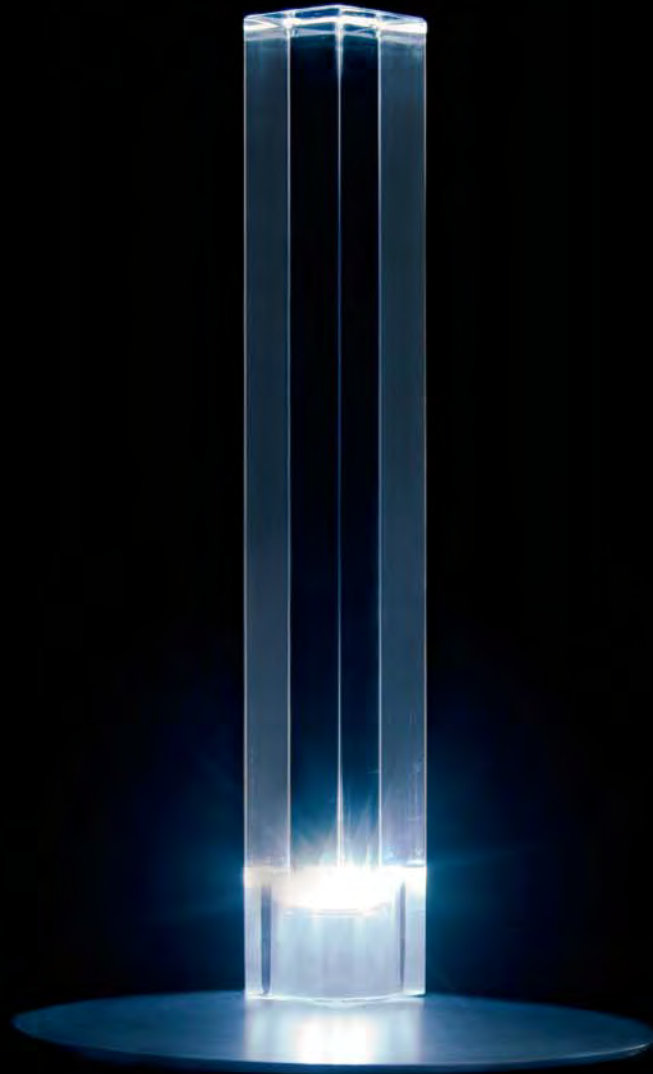

tavolo table	terra floor	parete_soffitto wall_ceiling	sospensione suspension	esterno outdoor

dati tecnici technical data p. 238



SWITCH 206

Lampada da tavolo a luce diretta e indiretta. Riflettore e struttura in metallo. Accensione con dimmer mediante la rotazione del riflettore.

Table lamp giving direct and indirect light. Metal structure and reflector. Dimmerable lighting by reflector's rotation.

Lampe de table à éclairage direct et indirect. Réflecteur et structure en métal. Allumage avec commande d'intensité d'éclairage par rotation du réflecteur.

Tischleuchte mit direktem und indirektem Licht. Reflektor und Struktur aus Metall. Einschaltung mit Dimmer durch Drehen des Reflektors.

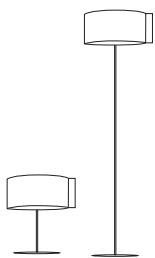

tavolo table	terra floor	parete soffitto wall ceiling	sospensione suspension	esterno outdoor
p. 83				
dati tecnici technical data p. 241				









LUTZ 290

Lampada da tavolo con LED, orientabile, a luce diretta. Braccio basculante con rotazione di 360° sulle base e sul supporto verticale. Riflettore orientabile e reclinabile. Base in metallo verniciato bianco o nero opaco e struttura in metallo cromato o verniciato bianco o nero opaco.

Adjustable table lamp giving direct light, with LED. Pivoting arm with 360° rotation at the base and support. Revolving and bendable reflector. Base in opaque white or black lacquered metal, structure in chromium-plated or opaque white or black.

Lampe de table avec LED, orientable, à éclairage direct. Bras oscillant avec rotation de 360° sur la base et le support vertical. Réflecteur pivotant et inclinable. Base en métal laqué blanc ou noir mat et structure en métal chromé ou laqué blanc ou noir mat.

Tischleuchte mit orientierbarem, indirektem LED Licht. Mit 360° drehbarem Schwenkarm auf dem Fuß und auf dem vertikalem Gestell. Orientierbarer und neigbarer Reflektor. Fuß aus mattlackiertem Metall in weiß oder schwarz und Gestell aus verchromten Metall oder mattlackiert in weiß oder schwarz.



tavolo table	terra floor	parete_soffitto wall_ceiling	sospensione suspension	esterno outdoor

dati tecnici_technical data p. 240





Lampade da terra



Floor lamps Lampadaires Stehleuchten





COUPE' Joe Colombo 1967

COUPE' 3320/R

Lampada da terra a luce diretta, base e struttura in metallo verniciato, arco cromato girevole e regolabile in altezza, riflettore in alluminio verniciato.

Floor lamp giving direct light, metal lacquered base and structure, revolving and height adjustable chromium-plated arc, lacquered aluminium reflector.

Lampadaire à lumière directe, base et structure en métal verni, arc chromé pivotant et réglable en hauteur, réflecteur en aluminium verni.

Stehleuchte mit direktem Licht, Sockel und Struktur aus lackiertem Metall, verchromter schwenkbarer und Höhenverstellbarer Bogen, Reflektor aus lackiertem Aluminium.

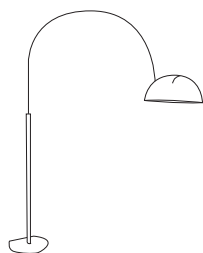

tavolo table	terra floor	parete_soffitto wall_ceiling	sospensione suspension	esterno outdoor

dati tecnici_technical data p. 256







COUPE' 3321

Lampada da terra a luce diretta, base in metallo verniciato, asta cromata; riflettore, orientabile e regolabile, in alluminio verniciato.

Floor lamp giving direct light, lacquered metal base, chromium-plated stem, adjustable reflector in lacquered aluminium.

Lampadaire à lumière directe, base en métal verni, tige chromée, réflecteur orientable et réglable en aluminium verni.

Stehleuchte mit direktem Licht, Fuß aus lackiertem Metall, verchromter Stab, drehbarer und verstellbarer Reflektor aus lackiertem Aluminium.

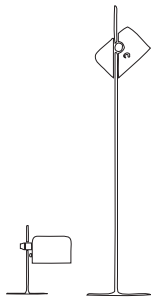

tavolo table	terra floor	parete_soffitto wall_ceiling	sospensione suspension	esterno outdoor
p. 29				
dati tecnici_technical data p. 256				







SPIDER Joe Colombo 1965

SPIDER 3319

Lampada da terra a luce diretta, base in metallo verniciato, asta cromata; riflettore, orientabile e regolabile, in alluminio verniciato.

Floor lamp giving direct light, lacquered metal base, chromium-plated stem, adjustable reflector in lacquered aluminium.

Lampadaire à lumière directe, base en métal verni, tige chromée, réflecteur orientable et réglable en aluminium verni.

Stehleuchte mit direktem Licht, Sockel aus lackiertem Metall, verchromter Stab, drehbarer und verstellbarer Reflektor aus lackiertem Aluminium.

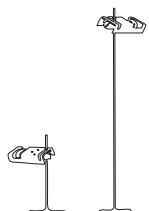

tavolo
table

terra
floor

parete_soffitto
wall_ceiling

sospensione
suspension

esterno
outdoor

p. 23

dati tecnici_technical data p. 257



AGNOLI Tito Agnoli 1954

AGNOLI 387

Lampada da terra a luce diretta, base in Travertino, stelo e riflettore, orientabile e regolabile in altezza, nichelati e spazzolati.

Floor lamp giving direct light, Travertino stone base, stem and height adjustable reflector mat nickel-plated.

Lampadaire à lumière directe, base en pierre Travertino, tige et réflecteur orientable et réglable en hauteur nickelés et brossés.

Stehleuchten mit direktem Licht, Sockel aus Travertino Marmor, Stab und drehbarer höhenverstellbarer Reflektor matt vernickelt.



tavolo table	terra floor	parete_soffitto wall_ceiling	sospensione suspension	esterno outdoor

dati tecnici_technical data p. 250



SHER 348

Lampada da Terra a luce indiretta e diffusa. Diffusore conico in alluminio tagliato al laser. Base e struttura in metallo verniciato. Accensione con dimmer.

Floor lamp giving in direct and diffused light. Cone diffuser in laquered aluminium laser-cut. Lacquered metal base and Structure. With dimmer switch.

Lampadaire à éclairage indirect et diffus. Diffuseur conique en aluminium gravé au laser et laqué. Base et structure de métal laqué. Allumage avec variateur d'intensité lumineuse.

Stehleuchte für indirekte, diffuse Beleuchtung. Kegelförmiger Lichtdiffusor aus aluminium und laserbearbeitetem. Fuß und Gestell aus lackiertem Metall. Helligkeitssteuerung mit Dimmer.



tavolo table	terra floor	parete_soffitto wall_ceiling	sospensione suspension	esterno outdoor

dati tecnici_technical data p. 243

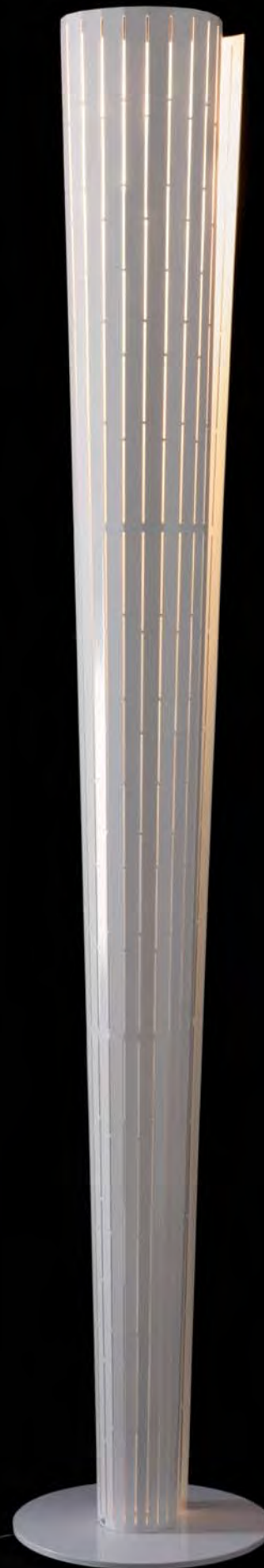



LU-LU Stefano Casciani 1996

LU-LU 311

Lampada da terra. Diffusore in vetro di Murano. Base in metallo spazzolato. Asta in metallo cromato. Doppia accensione dimmer/interruttore.

Floor lamp. Murano glass diffuser. Brushed metal base. Chrominium-plated metal stand. Double switch/dimmer.

Lampadaire avec diffuseur en verre de Murano. Base en métal brossé. Tige en métal chromé. Double allumage dimmer/interrupteur.

Stehleuchte. Streukörper aus Murano Glas. Fuß aus aufgerauhtem Metall. Stange aus verchromtem Metall. Doppeldimmer/Schalter.

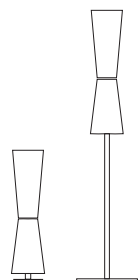

tavolo
table

terra
floor

parete soffitto
wall ceiling

sospensione
suspension

esterno
outdoor

p. 37

dati tecnici technical data p. 240





TEDA 332

Lampada da terra a luce diretta e diffusa. Struttura in acciaio inox satinato. Diffusore in PMMA opale satinato. Copri diffusore in vetro pyrex trasparente. Accensione con dimmer.

Floor lamp with direct and diffused light. Satined stainless steel structure. Satin-finished opal PMMA diffuser. Pyrex transparent cover diffuser. With dimmer.

Lampadaire à lumière directe et diffuse. Structure en acier inox satiné. Diffuseur en PMMA opale satiné. Couvre diffuseur en verre pyrex transparent. Avec dimmer

Steleuchte mit direktem und gestreutem Lichtstrahl. Struktur aus satiniertem Edelstahl Diffusor aus satiniertem opalem PMMA. Diffusorabdeckung aus transparentem Pyrex-Glas. Mit dimmer.

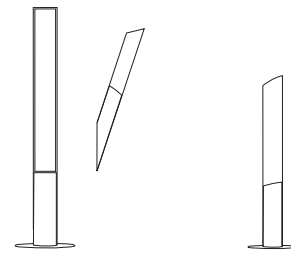

tavolo table	terra floor	parete soffitto wall_Ceiling	sospensione suspension	esterno outside
		p. 227		p. 229
dati tecnici technical data p. 243				





SHERWOOD 338

Lampada da terra a luce indiretta e diffusa. Diffusore conico in legno di Mogano accoppiato con Makrofol opalino. Base e struttura in metallo verniciato. Accensione con dimmer.

Floor lamp giving indirect and diffused light. Cone diffuser in Mahogany and opaline Makrofol. Lacquered metal base and Structure. With dimmer switch.

Lampadaire à éclairage indirect et diffus. Diffuseur conique en acajou avec Makrofol opalin. Base et structure de métal laqué. Allumage avec variateur d'intensité lumineuse.

Stehleuchte für indirekte, diffuse Beleuchtung. Kegelförmiger Lichtdiffusor aus Mahagoni und milchweißem Makrofol. Fuß und Gestell aus lackiertem Metall. Helligkeitssteuerung mit Dimmer.



tavolo table	terra floor	parete_soffitto wall_ceiling	sospensione suspension	esterno outdoor

dati tecnici technical data p. 244









SWITCH 306

Lampada da terra a luce diretta ed indiretta. Riflettore e struttura in metallo. Accensione con dimmer mediante la rotazione del riflettore.

Floor lamp giving direct and indirect light. Metal structure and reflector. Dimmerable lighting by reflector's rotation.

Lampadaire à éclairage direct et indirect. Réflecteur et structure en métal. Allumage avec commande d'intensité d'éclairage par rotation du réflecteur.

Stehleuchte mit direktem und indirektem Licht. Reflektor und Struktur aus Metall. Einschaltung mit Dimmer durch Drehen des Reflektors.

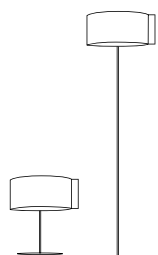

tavolo table	terra floor	parete_soffitto wall_ceiling	sospensione suspension	esterno outdoor
p. 51				
dati tecnici_technical data p. 242				

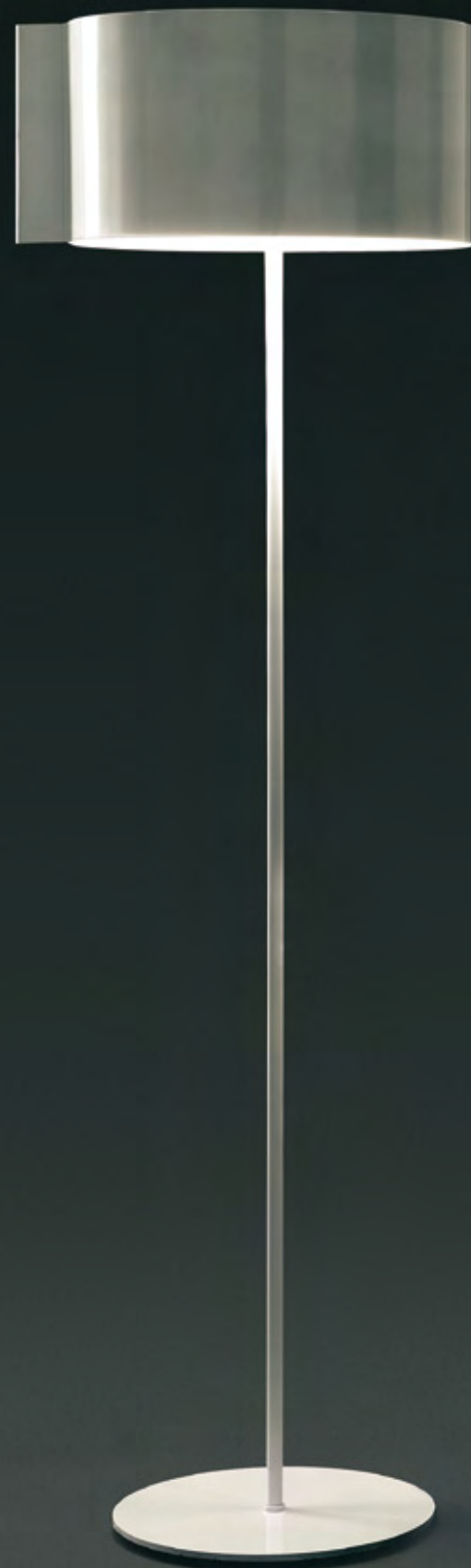



DO WITH 339

Lampada da terra (Luminator) a luce indiretta. Struttura conificata e base in metallo verniciato.

Floor lamp (Luminator) giving indirect light. Structure, with a coned shape, and base in painted metal.

Lampadaire (Luminator) à éclairage indirect. Structure, en cône, et socle en métal laqué.

Stehleuchte (Strahler) für indirektem Licht Konifizierter Ständer und Fuß aus lackiertem Metall.

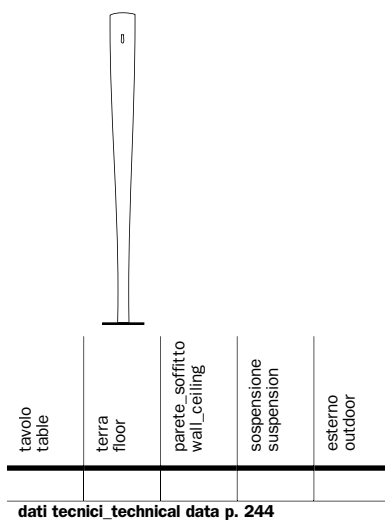







BETH 249, 349

Lampada da terra e da tavolo a luce indiretta e riflessa. Struttura in alluminio con lente antiabbagliamento in vetro satinato. Base e struttura interna in metallo. Accensione con touch dimmer.

Floor and table lamp giving indirect and reflected light. Aluminium structure with satined anti-glare glass lens. Base and internal structure in metal. With touch dimmer.

Lampadaire et lampe de table à éclairage indirect et réfléchi. Structure en aluminium avec verre anti-éblouissement dépoli. Base et structure interne en métal. Allumage par variateur d'intensité tactile.

Stehleuchte oder Tischleuchte mit indirekt reflektierendem Licht. Gestell aus Aluminium mit abblendender Linse aus satiniertem Glas. Innenstruktur und Fuß aus Metall. Helligkeitssteuerung mit Touch-Dimmer.

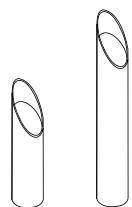

tavolo table	terra floor	parete_soffitto wall_ceiling	sospensione suspension	esterno outdoor
x	x	x	x	x

dati tecnici technical data p. 261





PASCAL Vico Magistretti 1983

PASCAL 345

Lampada da terra a luce indiretta e riflessa in alluminio verniciato bianco, doppia accensione indipendente, base in pietra Serena.

Floor lamp giving indirect and reflected light in white lacquered aluminium, independent double lighting, Pietra Serena base.

Lampadaire à lumière indirecte et réfléchie en aluminium verni blanc, double allumage indépendant, base en Pietra Serena.

Stehleuchte mit indirektem und reflektiertem Licht aus weiss lackiertem Aluminium, unabhängige Doppelentzündung, Sockel aus Pietra Serena.

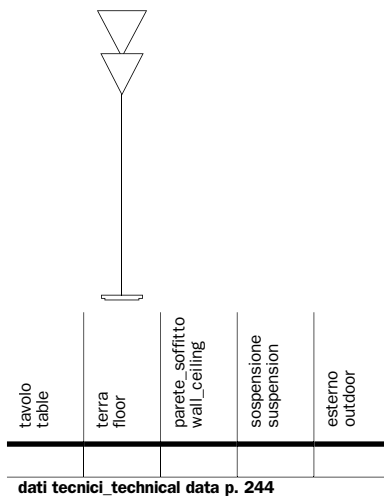



COLOMBO 626

Lampada da terra, con dimmer, a luce diretta ed indiretta, base in acciaio verniciato, stelo cromato; riflettore, orientabile e regolabile in altezza, in alluminio verniciato.

Floor lamp with dimmer giving direct and indirect light, lacquered steel base, chromium-plated stem, height adjustable reflector in lacquered aluminium.

Lampadaire avec dimmer à lumière directe et indirecte, base en acier verni, tige chromée, réflecteur orientable et réglable en hauteur, en aluminium verni.

Steleuchte mit Dimmer mit direktem und indirektem Licht, Sockel aus lackiertem Stahl, verchromter Stab, drehbarer und höhenverstellbarer Reflektor aus lackiertem Aluminium.

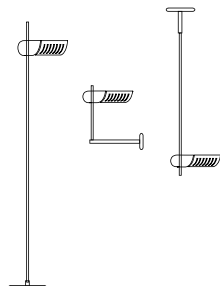

tavolo table	terra floor	parete_soffitto wall_ceiling	sospensione suspension	esterno outdoor
		p. 145	p. 189	

dati tecnici_technical data p. 237







COLOMBO 669

Lampada da terra a luce indiretta.
Stelo cromato. Base in metallo
verniciato. Riflettore, regolabile in
altezza, in alluminio verniciato.
Accensione con dimmer.

Floor lamp giving indirect light.
Chromium-plated stem. Lacquered
metal base. Height adjustable reflector
in lacquered aluminium. Lighting with
dimmer.

Lampe de terre à éclairage indirect,
tige chromée, base en métal peint,
réflecteur réglable en hauteur, en
aluminium peint. Allumage avec
commande d'intensité d'éclairage.

Bodenleuchte mit indirektem Licht,
verchromter Ständer, Fuß aus
lackiertem Metall, höhenverstellbarer
Reflektor aus lackiertem Aluminium.
Einschaltung mit Dimmer.

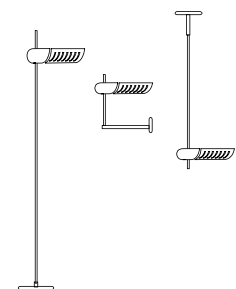

tavolo table	terra floor	pare- te_ soffitto	sospensione suspension	esterno outdoor
		p. 147	p. 191	

dati tecnici_technical data p. 238





DIM 333

Lampada da terra con dimmer, a luce diretta ed indiretta, base in acciaio verniciato, stelo cromato, riflettore, orientabile e regolabile in altezza, in alluminio verniciato.

Floor lamp with dimmer giving direct and indirect light, lacquered steel base, chromium-plated stem, height adjustable reflector in lacquered aluminium.

Lampadaire avec dimmer, lumière directe et indirecte, base en acier verni, tige chromée, réflecteur orientable et réglable en hauteur, en aluminium verni.

Stehleuchte mit Dimmer mit direktem und indirektem Licht, Sockel aus lackiertem Stahl, verchromter Stab, drehbarer und höhenverstellbarer Reflektor aus lackiertem Aluminium.

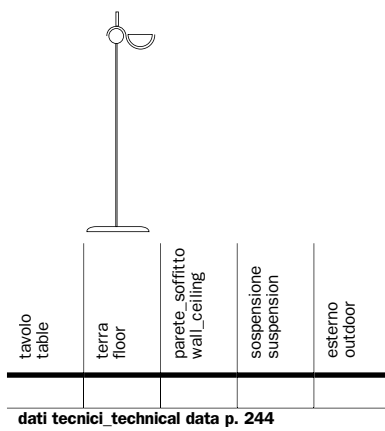





Lampade da parete e soffitto



Wall ceiling lamps Appliques et plafonniers Wand und deckenleuchten





FIORE 103, 123, 173, 139

Lampada da parete e soffitto a luce diretta e diffusa, in vetro soffiato trasparente. Struttura in metallo cromato a 3 luci a triangolo (103), a 3 luci in linea (123), a 7 luci a fiore (173), ad una luce (139).

Wall and ceiling lamp in transparent blown glass giving direct and diffused light. Chromium-plated metal structure with 3 lights in a triangular position (103), 3 lights in a straight line (123) or 7 lights on a flower disposition (173), with 1 light (139).

Applique et plafonnier à éclairage direct et diffus en verre soufflé transparent. Structure en métal chromé à 3 ampoules en triangle (103), à 3 ampoules en ligne (123) ou à 7 ampoules en forme de fleur (173), à 1 ampoule (139).

Wand- und Hängeleuchte mit direktem und diffusem Licht aus durchsichtigem, geblasenem Glas. Struktur aus verchromtem Metall mit 3 im Dreieck angeordneten Lichtern (103), mit 3 in einer Linie angeordneten Lichtern (123) bzw. 7 blumenförmig angeordneten Lichtern (173), mit 1 licht (139).

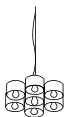

tavolo table	terra floor	parete_soffitto wall_ceiling	sospensione suspension	esterno outdoor
			p. 181	
dati tecnici_technical data p. 247				





PIN STRIPE 115, 119

Lampada da parete a luce diffusa,
in vetro trasparente decorato.
Struttura in metallo verniciato bianco.

Wall lamp giving diffused light, in
decorated transparent glass. Metal
painted white structure.

Applique à éclairage diffus en verre
transparent décoré. Structure en métal
peint blanc.

Tischleuchte mit diffusem Licht aus
verziertem, durchsichtigem Glas.
Struktur aus weißlackiertem Metall.

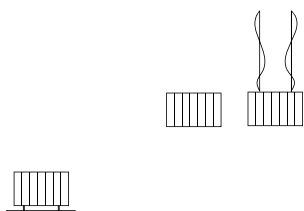

tavolo table	terra floor	parete_soffitto wall_ceiling	sospensione suspension	esterno outdoor
p. 41			p. 177	
dati tecnici technical data p. 241				



DIAMOND 181, 181/F

Lampada da parete/soffitto per interno (181) o per esterno (181/F) a luce diffusa. Diffusore in vetro stampato trasparente e sabbiato. Supporto in acciaio inox.

Wall/ceiling lamp for interiors (181) and exteriors (181/F) with diffused lighting. Sand-blasted and transparent moulded glass diffuser. Stainless steel support.

Applique/plafonnier d'intérieur (181) et d'extérieur (181/F) à lumière diffuse. Diffuseur en verre moulé transparent et sablé. Support en acier inox.

Wand/Deckenleuchte für den Innenbereich (181) oder Aussenbereich (181/F) mit diffusem Licht. Schirm aus transparentem Gussglas, innen mattes Glass, Struktur aus Edelstahl.



tavolo table	terra floor	parete_soffitto wall_ceiling	sospensione suspension	esterno outdoor

dati tecnici technical data p. 246



DROP Tito Agnoli 1954

DROP 156, 157

Lampada da parete o soffitto a luce diretta e diffusa, in vetro soffiato opalino acidato. Struttura in acciaio inox satinato.

Wall/ceiling lamp giving direct and diffused light, in opaline opaque blown glass. Satined stainless steel structure.

Applique/plafonnier à éclairage directe et diffus en verre soufflé opalin acidé. Structure en acier inox satiné.

Wand-Deckenleuchte mit direktem und diffusem Licht aus opal matt geblasenem Glas. Struktur aus Satiniertem Edelstahl.

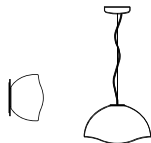

tavolo table	terra floor	parete soffitto wall_ceiling	sospensione suspension	esterno outdoor
			p. 175	

dati tecnici_technical data p. 239





**ALIAS 124/SP, 178/SP,
198/SP**

Lampada da parete e soffitto a luce diffusa. Diffusore in vetro soffiato opalino acidato e struttura in metallo zincato. Disco esterno in vetro a specchio.

Wall or ceiling lamp with direct and diffused light. Lampshade in opaline opaque blown glass with zinc-plated metal structure. External disk in mirrored glass.

Applique et plafonnier à lumière directe et diffuse. Diffuseur en verre soufflé opalin acidé et structure en métal galvanisé. Disque externe en verre miroir.

Wand und Deckenleuchte mit direktem und diffusem Licht. Leuchtkörper aus geblasenem getrübttem opal Glas. Struktur aus zink-plattiertem Metall. Außenscheibe aus Spiegelglas.



tavolo table	terra floor	parete soffitto wall ceiling	sospensione suspension	esterno outdoor

dati tecnici technical data p. 245



LINE 147, 149

Lampada da parete a luce indiretta (up & down) con diffusore di sagoma ovale realizzato in vetro pyrex trasparente. Struttura e schermo riflettente in alluminio lucido.

Wall lamp giving indirect light (up & down) in transparent oval Pyrex glass. Structure and reflecting screen in polished aluminium.

Applique à éclairage indirect (up & down) avec diffuseur de forme ovale en verre Pyrex transparent. Structure et écran réflecteur en aluminium poli.

Wandleuchte mit indirektem Licht (up & down) mit ovalem Lichtdiffusor aus transparentem Pyrex-Glas. Gestell und reflektierender Schirm aus glänzendem Aluminium.

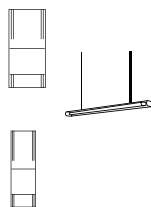

tavolo table	terra floor	parete_soffitto wall_ceiling	sospensione suspension	esterno outdoor
			p. 193	
dati tecnici_technical data p. 259				

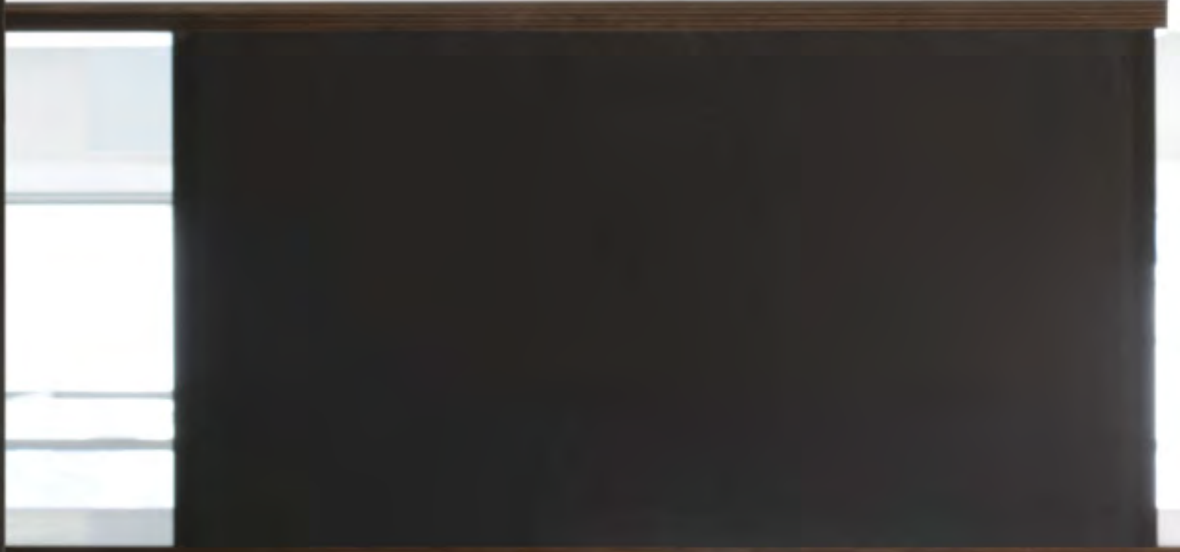

LINE 147/C, 149/C

Lampada da parete a luce indiretta (up & down) e diffusa. Diffusore esterno in vetro pyrex trasparente di sagoma ovale. Struttura in alluminio lucido e schermo diffondente in fibra composita.

Wall lamp giving indirect light (up & down) and diffused light in transparent oval pyrex glass. Structure in polished aluminium. Fibre composite screen.

Applique à éclairage indirect (up & down) et diffus. Diffuseur externe en verre Pyrex transparent de forme ovale.

Structure en aluminium poli avec écran diffuseur en fibres composites.

Wandleuchte mit indirektem und diffusem Licht (up & down). Äußerer ovaler Lichtdiffusor aus transparentem Pyrex-Glas. Gestell aus glänzendem Aluminium und Lichtschirm aus Fasergemisch.

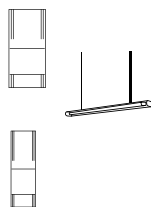

tavolo table	terra floor	parete_soffitto wall_ceiling	sospensione suspension	esterno outdoor
-----------------	----------------	---------------------------------	---------------------------	--------------------

p. 193

dati tecnici_technical data p. 259



JK 780

Lampada da parete in metallo verniciato a luce indiretta e riflessa. Colori bianco opaco oppure bicolore con interno verde chiaro.

Wall lamp giving indirect and reflected light in lacquered metal. Available colors: matt white and two-colors with light green on the inside.

Applique en métal laqué à éclairage indirect et réfléchi. Blanc mat ou à deux tons avec intérieur vert clair.

Wandleuchte aus lackiertem Metall mit indirektem, reflektierendem Licht. Mattweiß oder zweifarbig, Innenseite in hellgrün.



tavolo table	terra floor	parete soffitto wall_ceiling	sospensione suspension	esterno outdoor

dati tecnici_technical data p. 260



KELLY 790, 791

Lampada da parete a luce up & down in metallo curvato e lavorato al laser. Piastra a muro in metallo verniciato bianco. Schermo in metallo verniciato bianco oppure cromato.

Wall lamp giving up & down light in curved laser-cut metal. White lacquered metal wall plate. White lacquered or chromium-plated metal screen.

Applique à éclairage up & down de métal courbe et gravé au laser. Plaque murale de métal laqué blanc. Écran de métal laqué blanc ou chromé.

Wandleuchte mit up & down Licht aus gebogenem und laserbearbeitetem Metall. Wandplatte aus weißlackiertem Metall. Metallschirm weißlackiert oder verchromt.



tavolo table	terra floor	parete soffitto wall ceiling	sospensione suspension	esterno outdoor

dati tecnici technical data p. 260



SIXTY Oluce 2006



SIXTY 107, 127, 137

Lampada da parete e soffitto a luce diretta e diffusa. Diffusore in vetro soffiato opalino acidato. Struttura in metallo zincato.

Wall ceiling lamp giving direct and diffused light. Opaline opaque blown glass diffuser. Zinc-plated structure.

Applique/plafonnier à lumière directe et diffuse. Diffuseur en verre soufflé opalin acidé. Structure en métal galvanisé.

Wand und Deckenleuchte mit direktem und gestreutem Licht. Leuchtkörper aus matt geblasenem Glass. Struktur aus zinc-plattiertem Metall.



tavolo table	terra floor	parete soffitto wall ceiling	sospensione suspension	esterno outdoor

dati tecnici technical data p. 248-249



1960

162, 162/F, 163, 164, 165

Lampada da parete/soffitto per interno ed esterno a luce diretta e diffusa. Struttura in metallo e policarbonato, diffusore in vetro stampato.

Inside and outside wall/ceiling lamp with direct and diffused light. Metal and polycarbonate structure, glass moulded diffuser.

Applique/plafonnier pour intérieur et extérieur à lumière directe et diffuse. Structure en métal et polycarbonate, diffuseur en verre moulé.

Innen-und Aussenwand-oder Deckenleuchte mit direktem und diffusem Licht. Streukörper aus Gussglas.

tavolo table	terra floor	parete_soffitto wall_ceiling	sospensione suspension	esterno outdoor
				p. 221
dati tecnici technical data p. 249				









**DIAMANTE 182, 182/F,
183, 184, 185**

Lampada da parete/soffitto per esterno e interno a luce diretta e diffusa.
Struttura in acciaio inox. Diffusore in vetro pyrex.

Inside and outside wall/ceiling lamp with direct and diffused light. Stainless steel structure. Pyrex glass diffuser.

Applique/plafonnier pour extérieur et intérieur à lumière directe et diffuse. Structure en acier inox. Diffuseur en verre pyrex.

Innen-und Aussenwand-oder Deckenleuchte mit direktem und diffusem gestreutem Lichtstrahl. Struktur aus edelstahl. Diffusor aus Pyrex Glas.



tavolo table	terra floor	parete_soffitto wall_ceiling	sospensione suspension	esterno outdoor
				p. 223
dati tecnici_technical data p. 245				



DIAMANTE/O 191, 192

Lampada da parete/soffitto per esterno e interno a luce diretta e diffusa.
Struttura in acciaio inox. Diffusore in vetro pyrex.

Inside and outside wall/ceiling lamp with direct and diffused light. Stainless steel structure. Pyrex glass diffuser.

Applique/plafonnier pour extérieur et intérieur à lumière directe et diffuse.
Structure en acier inox. Diffuseur en verre pyrex.

Innen-und Aussenwand-oder Deckenleuchte mit direktem und diffusem gestreutem Lichtstrahl.
Struktur aus edelstahl. Diffusor aus Pyrex Glas.



tavolo table	terra floor	parete_soffitto wall_ceiling	sospensione suspension	esterno outdoor
				p. 225

dati tecnici_technical data p. 258



TESSERA 113

Lampada da parete/soffitto a luce diretta e diffusa. Diffusore orientabile in vetro stampato, struttura in ottone cromato.

Wall/ceiling lamp with direct and diffused light. Adjustable diffuser in moulded glass. Chromed brass structure.

Applique/plafonnier à lumière directe et diffuse. Diffuseur orientable en verre moulé. Structure en laiton chromé.

Wand-Deckenleuchte mit direktem und gestreutem Lichtstrahl. Verstellbare Diffusoren aus bedrucktem Glas. Struktur aus verchromtem Messing.



tavolo table	terra floor	parete_soffitto wall_ceiling	sospensione suspension	esterno outdoor

dati tecnici_technical data p. 248



TESSERA 113/SP

Lampada da parete/soffitto a luce diretta e indiretta. Diffusori orientabili in vetro stampato (uno trattato con finitura dicroica). Struttura in ottone cromato.

Wall/ceiling lamp with direct and indirect light. Adjustable diffusers in moulded glass (one treated with a dichroic finish). Chromed brass structure.

Applique/plafonnier à lumière directe et indirecte. Diffuseur orientables en verre moulé (un traité avec finition dichroïque). Structure en laiton chromé.

Wand-Deckenleuchte mit direktem und indirektem Licht. Verstellbare Diffusoren aus bedrucktem Glas (Einer davon in dichroitischer Ausführung). Struktur aus Verchromtem Messing.

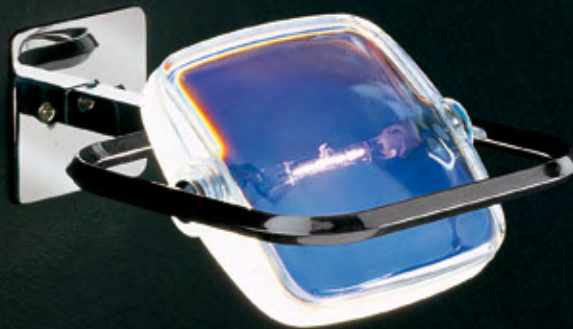

tavolo table	terra floor	parete_soffitto wall_ceiling	sospensione suspension	esterno outdoor

dati tecnici_technical data p. 248



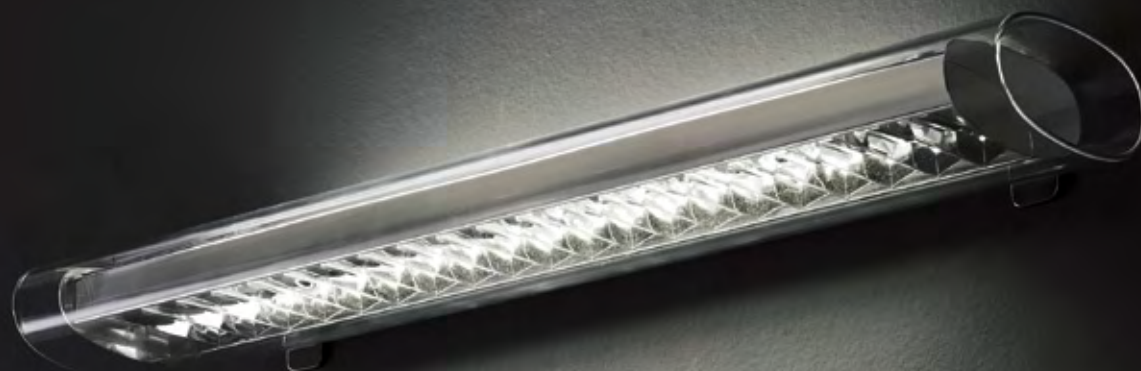

LINE 148

Lampada da parete a luce diretta e indiretta. Struttura in alluminio lucido e riflettore "dark light". Copertura in vetro Pyrex trasparente. Attacco a muro in metallo cromato.

Wall lamp giving direct and indirect light. Glossy aluminium structure and reflector "dark light". Covering in transparent Pyrex glass. Chromium-plated metal wall fixing.

Applique à éclairage direct et indirect. Structure en aluminium brillant et réflecteur "dark light". Couverture en verre Pyrex transparent. Fixation murale en métal chromé.

Wandleuchte mit direktem und indirektem Licht. Struktur aus glänzendem Aluminium und Darklight-Reflektor. Abdeckung aus durchsichtigem Pyrexglas. Wandanschluss aus verchromtem Metall.

tavolo table	terra floor	parete_soffitto wall_ceiling	sospensione suspension	esterno outdoor
			p. 197	
dati tecnici technical data p. 255				



UNIVERSAL 108, 109

Lampada da parete a luce diretta e diffusa. Struttura in alluminio lucido, diffusori in vetro trasparente sabbiato, diffusore frontale in vetro "stopsol" oppure nero.

Wall lamp giving direct and diffused light. Structure in glossy aluminium, sand-blasted glass diffuser, "stopsol" front glass diffuser or black.

Applique à éclairage direct et diffus. Structure en aluminium brillant, diffuseur en verre transparent sablé, diffuseur frontal en verre "stopsol", noir.

Wandleuchte mit direktem und diffusem Licht. Struktur aus glänzendem Aluminium, Diffusoren aus durchsichtigem, sandgestrahltem Glas, vorderer Diffusor aus Glas "Stopsol", in der Ausführung Schwarz.



tavolo table	terra floor	parete_soffitto wall_ceiling	sospensione suspension	esterno outdoor

dati tecnici_technical data p. 257







UNIVERSAL 129, 106

Lampada da parete a luce diretta e diffusa. Struttura in alluminio lucido, diffusore in vetro trasparente sabbiato, diffusore frontale in vetro "stopsol" o nero.

Wall lamp giving direct and diffused light. Structure in glossy aluminium, sand-blasted glass diffuser, "stopsol" or black front glass diffuser.

Applique à éclairage direct et diffus. Structure en aluminium brillant, diffuseur en verre transparent sablé, diffuseur frontal en verre "stopsol" ou noir.

Wandleuchte mit direktem und diffusem Licht. Struktur aus glänzendem Aluminium, Diffusor aus durchsichtigem, sandgestrahltem Glas, vorderer Diffusor aus Glas "Stopsol" bzw. in der Ausführung Schwarz.

tavolo table	terra floor	parete_soffitto wall_ceiling	sospensione suspension	esterno outdoor

dati tecnici technical data p. 257





COLOMBO Joe Colombo 1970

COLOMBO 761

Lampada da parete con stelo cromato, attacco a parete verniciato, riflettore in alluminio verniciato, orientabile e regolabile in altezza.

Wall lamp with chromium-plated stem, wall fixings lacquered and height adjustable reflector in lacquered aluminium.

Applique avec tige chromée, fixations à mur verni et réflecteur orientable et réglable en hauteur, en aluminium verni.

Wandleuchte, mit verchromter Stab, mit Lackiertem Wandhalterung. Drehbarer und Hoehverstellbarer Reflektor aus lackiertem Aluminium.



tavolo table	terra floor	parete_soffitto wall_ceiling	sospensione suspension	esterno outdoor
	p. 93		p. 189	
dati tecnici_technical data p. 237				

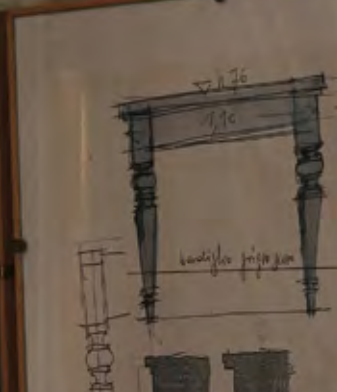
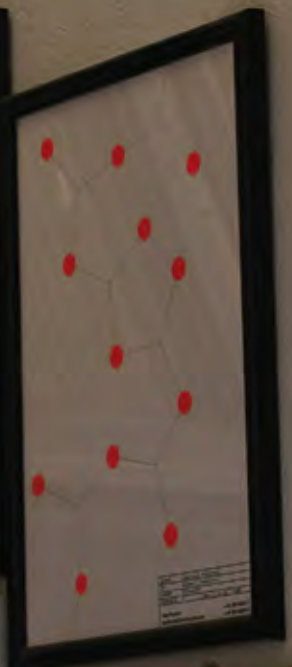

COLOMBO 769

Lampada da parete a luce indiretta con stelo cromato, attacco a parete verniciato e riflettore, regolabile in altezza, in alluminio verniciato.

Wall lamp giving indirect light. Chromium-plated stem, wall fixings lacquered and height adjustable reflector in lacquered aluminium.

Applique à éclairage indirect avec tige chromée, fixation murale peinte et réflecteur réglable en hauteur, en aluminium peint.

Wandleuchte mit indirektem Licht und Verchromter Ständer. Lackierter Wandanschluss und Höhenverstellbarer Reflektor aus lackiertem Aluminium.



tavolo table	terra floor	parete_sorfitto wall_ceiling	sospensione suspension	esterno outdoor
	p. 97		p. 191	
dati tecnici_technical data p. 238				



FRESNEL Joe Colombo 1966

FRESNEL 1148, 1148/F

Lampada da parete o soffitto per interno ed esterno a luce diretta e diffusa. Fusione in alluminio verniciato e diffusore in lente Fresnel.

Inside and outside wall or ceiling lamp giving direct and diffused light. Lacquered aluminium support and Fresnel lens diffuser.

Applique au plafonnier pour intérieur et extérieur à lumière directe et diffuse. Structure en aluminium verni et diffuseur en verre Fresnel.

Innen- und Aussenwand- oder Deckenleuchte mit direktem und diffusem Licht. Struktur aus lackiertem Aluminium und Leuchtkörper aus Fresnel Linse.



tavolo table	terra floor	parete_soffitto wall_ceiling	sospensione suspension	esterno outdoor
		p. 211		p. 209
dati tecnici technical data p. 252				

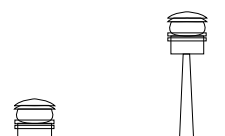

Lampade a sospensione



Suspension Lamps Lampes à suspension Hängeleuchten





SONORA Vico Magistretti 1976

SONORA 490, 493

Lampada a sospensione, a luce diretta e diffusa, in PMMA soffiato.

Suspension lamp, giving direct and diffused light, in blown PMMA.

Lampe à suspension, à éclairage direct et diffus, en PMMA soufflé.

Hängeleuchte für direktem und gestreutes Licht aus geblasenem PMMA.



tavolo table	terra floor	parete_soffitto wall_ceiling	sospensione suspension	esterno outdoor

dati tecnici_technical data p. 251







SONORA Vico Magistretti 1976

SONORA 411, 438

Lampada a sospensione a luce diretta e diffusa, in vetro soffiato di Murano.

Suspension lamp giving direct and diffused light, opaline blown Murano glass diffuser.

Lampe à suspension à lumière directe et diffuse, diffuseur en verre soufflé de Murano opalin.

Haengeleuchte mit direktem und diffusem Licht, Leuchtkeörper aus geblasenem Murano opal Glas.



tavolo table	terra floor	parete_soffitto wall_ceiling	sospensione suspension	esterno outdoor

dati tecnici_technical data p. 251







PLATEAU 476, 486

Lampada a sospensione a luce diffusa. Plateau di supporto in PMMA trasparente lavorato e lucidato al Laser. Globi in vetro soffiato opalino acidato, di diverse misure, posizionabili a scelta.

Suspension lamp giving diffuse light. Support plateau in transparent laser-finished and polished PMMA. Globes in opaline opaque blown glass in different sizes, that can be placed as wished.

Lampe à suspension à éclairage diffus. Plateau de support en PMMA transparent, gravé et poli au laser. Globes de verre soufflé opalin acidifié, de différentes tailles, positionnables selon votre choix.

Pendelleuchte mit diffusem Licht. Der Leuchtenkörper besteht aus transparentem, laserbearbeitetem PMMA. Die Kugeln unterschiedlicher Dimensionen aus säurebehandeltem, geblasenem Opalglas sind je nach Wunsch frei positionierbar.

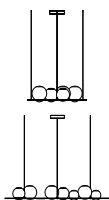

tavolo table	terra floor	parete_soffitto wall_ceiling	sospensione suspension	esterno outdoor

dati tecnici_technical data p. 239









COROA 480

Lampada a sospensione a 16 luci dirette e riflesse. Struttura in metallo verniciato con elementi schermanti e riflettenti in PMMA bispecchio o bianco opaco.

Suspension lamp with 16 direct and reflected light. Structure in lacquered metal with screening and reflecting elements in double-face mirror PMMA or opaque white.

Lampe à suspension constituée de 16 lumières directes et réfléchies. Structure en métal laqué avec éléments à effets d'écran et réfléchissants en PMMA, double miroir ou blanc mat.

Pendelleuchte mit 16 direkten und reflektierenden Strahlern. Gestell aus lackiertem Metall mit abblendenden und reflektierenden Elementen aus PMMA in beidseitiger Spiegelverglasung oder mattweiß lackiert.



tavolo table	terra floor	parete_sorfitto wall_ceiling	sospensione suspension	esterno outdoor

dati tecnici technical data p. 258



CIRCLES 429

Lampada a sospensione a luce diretta.
Corpo illuminante formato da 4 cilindri
di diversi diametri in tessuto accoppiato
riflettente.

Suspension lamp giving direct light.
Light fixture composed by 4 cylinders in
different diameters in reflecting
laminated textile.

Lampe à suspension à éclairage direct.
Armature d'éclairage comprenant 4
cylindres de diamètres différents en
tissu couplé réfléchissant.

Pendelleuchte mit direktem Licht. Der
Lichtkörper besteht aus 4 ineinander
befestigten, reflektierenden Stoff-
Zylindern von unterschiedlichem
Durchmesser.



tavolo table	terra floor	parete_sorffitto wall_ceiling	sospensione suspension	esterno outdoor

dati tecnici_technical data p. 259







CANOPY Francesco Rota 2009

CANOPY 421, 422

Lampada a sospensione a luce fluorescente indiretta, riflettore e schermo paraluce in metallo verniciato bianco, anche bicolore.

Suspension lamp giving indirect fluorescent light. Reflector and lampshade screen in lacquered metal white, or two-colors.

Lampe à suspension à éclairage fluorescent indirect, réflecteur et abat-jour métallique laqué blanc, également en deux tons.

Pendelleuchte mit indirektem, fluoreszierendem Licht, Lichtreflektor und Lampenschirm aus weißem PMMA, auch zweifarbig.



tavolo table	terra floor	parete_soffitto wall_ceiling	sospensione suspension	esterno outdoor

dati tecnici_technical data p. 261







DROP Tito Agnoli 1954

DROP 469

Lampada a sospensione, a luce diretta e diffusa, in vetro soffiato opalino acidato.

Suspension lamp giving direct and diffused light in opaline opaque blown glass.

Lampe à suspension à éclairage directe et diffus en verre soufflé opalin acidé.

Hängelampe mit direktem und diffusem Licht aus opal matt geblasenem Glas.



tavolo table	terra floor	parete_soffitto wall_ceiling	sospensione suspension	esterno outdoor
		p. 111		
dati tecnici_technical data p. 239				



PIN STRIPE 417



Lampada a sospensione a luce diffusa in vetro trasparente decorato. Struttura in metallo verniciato bianco.

Suspension lamp giving diffused light in decorated transparent glass. White metal painted structure.

Lampe à suspension à éclairage diffus en verre transparent décoré. Structure en métal peint blanc.

Hängeleuchte mit diffusem Licht aus verziertem, durchsichtigem Glas. Struktur aus weißlackiertem Metall.

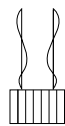

				
tavolo table	terra floor	parete_sorffitto wall_ceiling	sospensione suspension	esterno outdoor
p. 41		p. 107		
dati tecnici_technical data p. 241				



PIAZZA SAN MARCO Vico Magistretti 2005

PIAZZA SAN MARCO 453

Lampada a sospensione a luce diffusa.
Struttura a 12 bracci in metallo
cromato lucido.

Suspension lamp giving diffused light.
Lamp structure composed by 12 arms
in chromium-plated metal.

Lampe à suspension à lumière diffuse.
Structure à 12 branches en métal
chromé brillant.

Hängeleuchte mit diffusem Licht.
Struktur mit 12 Armen aus glänzendem
verchromtem Metall.

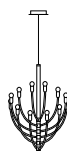

tavolo table	terra floor	parete_sorfitto wall_ceiling	sospensione suspension	esterno outdoor

dati tecnici_technical data p. 250



FIORE 423, 433

Lampada a sospensione, a luce diretta e diffusa, in vetro soffiato trasparente. Struttura in metallo cromato a 7 luci (423) oppure a 13 luci (433).

Suspension lamp in transparent blown glass giving direct and diffused light. Chromium-plated metal structure with 7 lights (423) or 13 lights (433).

Suspension à éclairage direct et diffus en verre soufflé transparent. Structure en métal chromé à 7 ampoules (423) ou à 13 ampoules (433).

Hängeleuchte mit direktem und indirektem Licht aus durchsichtigem, geblasenem Glas. Struktur aus verchromtem Metall mit 7 Lichtern (423) bzw. 13 Lichtern (433).

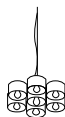

tavolo table	terra floor	parete_sorffitto wall_ceiling	sospensione suspension	esterno outdoor
		p. 105		
dati tecnici_technical data p. 247				







LANTERNA - LANTERNINA Laudani&Romanelli 1998

LANTERNA 477 LANTERNINA 471

Lampada a sospensione a luce diffusa.
Diffusori in vetro di Murano trasparente
e sabbiato. Struttura in metallo satinato
e anodizzato.

Suspension lamp giving diffused light.
Transparent and sand-blasted Murano
glass diffusers. Glazed anodized metal
structure.

Lampe à suspension à éclairage diffus
en verre de Murano transparent et
sablé. Structure en métal satiné et
anodisé.

Hängeleuchte mit diffusem Licht.
Leuchtkörper aus transparentem und
sandbestrahltem Murano-Glas. Struktur
aus mattem eloxiertem Metall.



tavolo table	terra floor	parete_soffitto wall_ceiling	sospensione suspension	esterno outdoor
-----------------	----------------	---------------------------------	---------------------------	--------------------

dati tecnici_technical data p. 238-250









COLOMBO Joe Colombo 1970

COLOMBO 885

Lampada da soffitto a luce diretta e indiretta, stelo cromato, attacco a soffitto verniciato, riflettore orientabile e regolabile in alluminio verniciato.

Ceiling lamp giving direct and indirect light, chromium-plated stem, lacquered ceiling fixing. Adjustable reflector in lacquered aluminium.

Plafonnier à lumière directe et indirecte, tige chromée, fixation à plafond verni. Réflecteur en aluminium verni orientable et réglable en hauteur.

Deckenleuchte mit direktem und indirektem Licht, verchromter Stab, Deckenhalterung lackiertem. Drehbarer verstellbarer Reflektor aus lackiertem Aluminium.

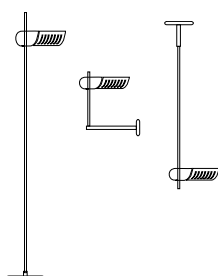

tavolo table	terra floor	parete_soffitto wall_ceiling	sospensione suspension	esterno outdoor
	p. 93	p. 147		
dati tecnici_technical data p. 237				





COLOMBO 889

Lampada da soffitto a luce indiretta con stelo cromato, attacco a soffitto verniciato e riflettore regolabile in altezza, in alluminio verniciato.

Ceiling lamp giving indirect light. Chromium-plated stem, lacquered ceiling fixing and height adjustable reflector in lacquered aluminium.

Plafonnier à éclairage indirect, tige chromée, fixation au plafond peinte, réflecteur réglable en hauteur en aluminium peint.

Deckenleuchte mit indirektem Licht. Verchromter Ständer, lackierter Deckenanschluss mit höhenverstellbarer Reflektor aus lackiertem Aluminium.



tavolo table	terra floor	parete_soffitto wall_ceiling	sospensione suspension	esterno outdoor
	p. 97	p. 147		
dati tecnici_technical data p. 238				



LINE Francesco Rota 2007



LINE 448, 449

Lampada a sospensione a luce diretta e indiretta. Struttura in alluminio lucido e riflettore "dark light". Copertura in vetro Pyrex trasparente.

Suspension lamp giving direct and indirect light. Glossy aluminium structure and reflector "dark light". Covering in Transparent Pyrex glass.

Suspension à éclairage direct et indirect. Structure en aluminium brillant et réflecteur "dark light". Couverture en verre Pyrex transparent.

Hängeleuchte mit direktem und indirektem Licht. Struktur aus glänzendem Aluminium und Darklight-Reflektor. Abdeckung aus durchsichtigem Pyrexglas.

tavolo table	terra floor	parete_soffitto wall_ceiling	sospensione suspension	esterno outdoor
		p. 137		
dati tecnici_technical data p. 255				







LINE/C Francesco Rota 2007

LINE 448/C, 449/C

Lampada a sospensione a luce diffusa.
Struttura in alluminio lucido e diffusore
in fibra composita. Copertura in vetro
pyrex trasparente sagomato ovale.

Suspension lamp giving direct and
diffused light. Glossy aluminium
structure and fibre composite diffuser.
Covering in transparent oval pyrex glass.

Lampe à suspension à éclairage diffus.
Structure en aluminium poli et diffuseur
en fibres composites. Abat-jour en verre
Pyrex transparent de forme ovale.

Pendelleuchte mit diffusem Licht.
Gestell aus glänzendem Aluminium und
Diffusor aus Fibergemisch. Abdeckung
aus transparentem, ovalem Pyrex Glas

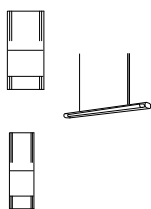

tavolo table	terra floor	parete_sorfitto wall_ceiling	sospensione suspension	esterno outdoor
		p. 115		
dati tecnici_technical data p. 255				

Lampade da esterno



Outside Lamps Lampes pour l'estxtérieur Aussenleuchten





STONES 207, 208, 215



Lampada da esterno/interno a luce diffusa, in polietilene bianco.

Outside and inside lamp with direct and diffused light, in white polyethylene.

Lampe d'extérieur et intérieur à lumière directe et diffuse, en Polyéthylène blanc.

Außen- und Innenleuchte mit direktem und gestreutem Lichtstrahl aus weissen Polyethylen.



				
tavolo table	terra floor	parete_soffitto wall_ceiling	sospensione suspension	esterno outdoor
p. 43				
dati tecnici technical data p. 254				



LYNDON Vico Magistretti 1977

LYNDON 350, 350/M

Lampada da terra per esterno. Struttura in metallo zincato verniciato nero, globi in policarbonato trasparente.

Outside floor lamp. Zinc-plated black lacquered metal structure, globes in transparent polycarbonate.

Lampadaire d'extérieur. Structure en métal galvanisé verni noir, globes en polycarbonate transparent.

Aussenstehleuchte. Struktur aus zinkplattiertem und schwarz lackiertem Metall, Kugel aus transparentem Polycarbonat.

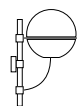

tavolo table	terra floor	parete_soffitto wall_ceiling	sospensione suspension	esterno outdoor

dati tecnici technical data p. 253







LYNDON Vico Magistretti 1977

LYNDON 160, 160/M

Lampada da parete per esterno.
Struttura in metallo zincato e verniciato
nero, globo in policarbonato
trasparente.

Outside wall lamp. Zinc-plated and black
lacquered metal structure, globe in
transparent polycarbonate.

Applique pour l'extérieur. Structure en
métal galvanisé et verni noir, globe en
polycarbonate transparent.

Aussenwandleuchten. Struktur aus zink-
plattiertem und schwarz lackiertem
Metall, Kugel aus transparentem
Polycarbonat.

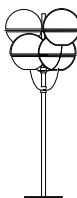
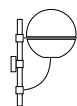

tavolo table	terra floor	parete_sorffitto wall_ceiling	sospensione suspension	esterno outdoor

dati tecnici technical data p. 253





FRESNEL Joe Colombo 1966

FRESNEL 1148/EC, 1148/EL

Lampada da terra per esterno a luce diretta e diffusa. Fusione in alluminio verniciato e diffusore in lente Fresnel. Palo in metallo zincato verniciato poliestere nero.

Outside floor lamp giving direct and diffused light. Lacquered aluminium support and Fresnel lens diffuser. Zinc-plated metal pole painted polyester black.

Lampadaire pour l'extérieur à lumière directe et diffuse. Structure en aluminium verni et diffuseur en verre Fresnel. Poteau en métal galvanisé verni en noir.

Stehleuchte für draußen mit direktem und diffusem Licht. Struktur aus lackiertem Aluminium und Leuchtkörper aus Fresnel linse. Stange aus zinkplattiertem Metall und polyester Schwarz gefärbt.

tavolo table	terra floor	parete_soffitto wall_ceiling	sospensione suspension	esterno outdoor
p. 149				
dati tecnici technical data p. 252				





FRESNEL Joe Colombo 1966

FRESNEL 1148, 1148/F

Lampada da parete o soffitto per interno ed esterno a luce diretta e diffusa. Fusione in alluminio verniciato e diffusore in lente Fresnel.

Inside and outside wall or ceiling lamp giving direct and diffused light. Lacquered aluminium support and Fresnel lens diffuser.

Applique au plafonnier pour intérieur et extérieur à lumière directe et diffuse. Structure en aluminium verni et diffuseur en verre Fresnel.

Innen- und Aussenwand- oder Deckenleuchte mit direktem und diffusem Licht. Struktur aus lackiertem Aluminium und Leuchtkörper aus Fresnel linse.



tavolo table	terra floor	parete_soffitto wall_ceiling	sospensione suspension	esterno outdoor
		p. 149		p. 209
dati tecnici technical data p. 252				



PILL-LOW 219

Lampada da esterno/interno a luce diffusa in polietilene bianco con rivestimento in tessuto lavabile per esterni. Utilizzabile anche come seduta.

Outdoor/indoor lamp giving diffused light in white polyethylene with cover in outdoor washable fabric. To be used as seat as well.

Lampe d'extérieur/intérieur à éclairage diffus en polyéthylène blanc avec revêtement en tissu lavable pour une utilisation en extérieur. Peut aussi être utilisée comme siège.

Leuchte für den Innen- und Außenbereich mit diffusem Licht aus weißem Polyethylen und waschbarem, für den Außenbereich geeignetem Stoffbezug. Kann auch als Sitzgelegenheit verwendet werden.

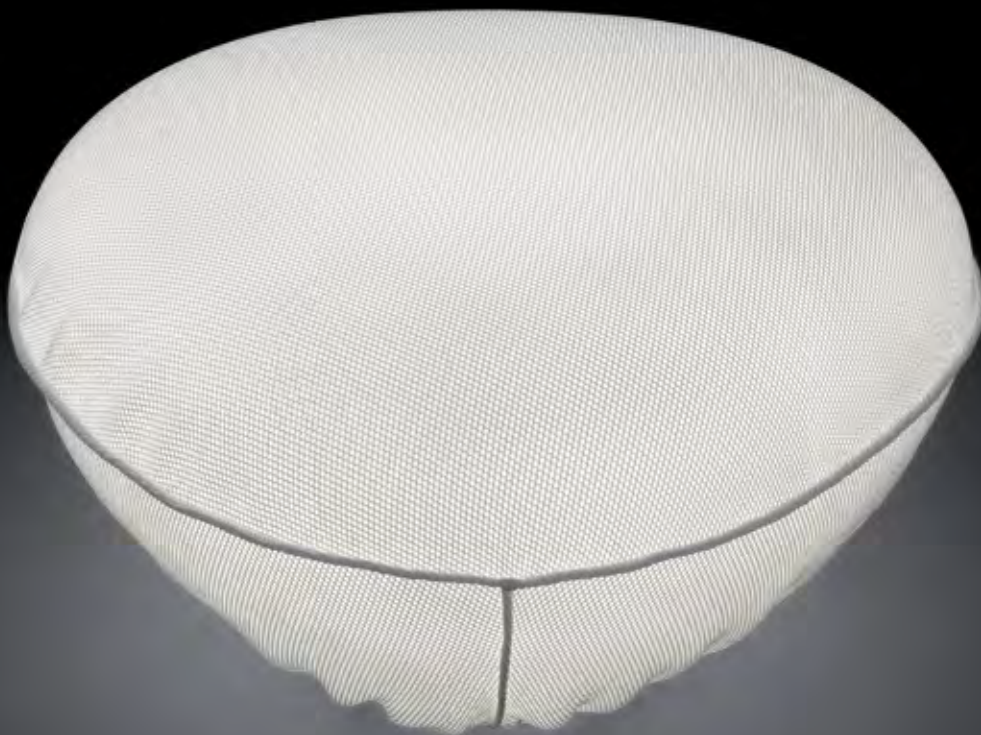

tavolo table	terra floor	parete_soffitto wall_ceiling	sospensione suspension	esterno outdoor

dati tecnici technical data p. 254







ELA 308, 318

Lampada da esterno a luce diretta a LED. Struttura in legno Accoya per esterno. Riflettore interno in alluminio anodizzato.

Outdoor lamp giving LED direct light. Structure in outdoor Accoya wood. Anodised aluminium internal reflector.

Lampe d'extérieur à éclairage direct par LED. Structure en bois Accoya pour l'extérieur. Réflecteur interne en aluminium anodisé.

Leuchte für den Außenbereich mit direktem LED Licht. Gestell aus Outdoor-Accoya-Holz, Innenreflektor aus eloxiertem Aluminium.



tavolo table	terra floor	parete_soffitto wall_ceiling	sospensione suspension	esterno outdoor

dati tecnici technical data p. 262









1960

162, 162/F, 163, 164, 165

Lampada da parete/soffitto per interno ed esterno a luce diretta e diffusa. Struttura in metallo e policarbonato, diffusore in vetro stampato.

Inside and outside wall/ceiling lamp for direct and diffused light. Metal and polycarbonate structure, moulded glass diffuser.

Applique/plafonnier pour intérieur et extérieur à lumière directe et diffuse. Structure en métal et polycarbonate, diffuseur en verre moulé.

Innen-und Aussenwand-oder Deckenleuchte mit direktem und diffusem Licht. Streukörper aus Gussglas.



tavolo table	terra floor	parete_soffitto wall_ceiling	sospensione suspension	esterno outdoor
		p. 125		

dati tecnici technical data p. 249



**DIAMANTE 182, 182/F, 183,
184, 185**



Lampada da parete/soffitto per esterno e interno a luce diretta e diffusa. Struttura in acciaio inox. Diffusore in vetro pyrex.

Inside and outside wall/ceiling lamp with direct and diffused light. Stainless steel structure. Pyrex glass diffuser.

Applique/plafonnier d'extérieur et intérieur à lumière directe et diffuse. Structure en acier inox. Diffuseur en verre pyrex.

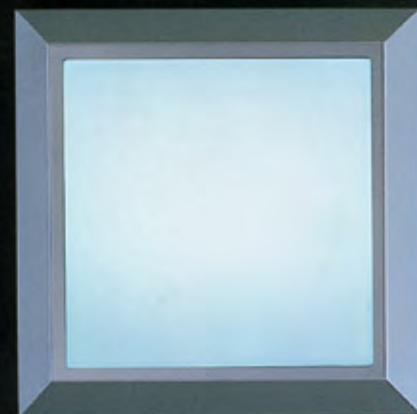
Innen-und Aussenwand-oder Deckenleuchte mit direktem und diffusem gestreutem Lichtstrahl. Struktur aus edelstahl. Diffusor aus Pyrex Glas.



tavolo table	terra floor	parete_soffitto wall_ceiling	sospensione suspension	esterno outdoor
				
p. 129				
dati tecnici technical data p. 245				



DIAMANTE/O 191, 192



Lampada da parete/soffitto per esterno e interno a luce diretta e diffusa. Struttura in acciaio inox. Diffusore in vetro pyrex

Inside and outside wall/ceiling lamp with direct and diffused light. Stainless steel structure. Pyrex glass diffuser.

Applique/plafonnier pour extérieur et intérieur à lumière directe et diffuse. Structure en acier inox. Diffuseur en verre pyrex.

Innen-und Aussenwand-oder Deckenleuchte mit direktem und diffusem gestreutem Lichtstrahl. Struktur aus edelstahl. Diffusor aus Pyrex Glas.



tavolo table	terra floor	parete_soffitto wall_ceiling	sospensione suspension	esterno outdoor
				
p. 131				
dati tecnici technical data p. 258				



TEDA 102

Lampada da parete per esterno/interno a luce indiretta e diffusa. Tubo diffusore in PMMA opale satinato, sagoma riflettente in PMMA trasparente. Attacco a parete in acciaio verniciato o satinato.

Outside and inside wall lamp with indirect and diffused light. Satin-finished opal PMMA diffuser tube, transparent PMMA reflecting tube holder. Lacquered or satined stainless steel fitting.

Applique d'extérieur et intérieur à lumière indirecte et diffuse. Tube diffuseur en PMMA opale satiné, forme réfléchissante en PMMA transparent. Fixation en acier inox verni ou satiné.

Wandleuchte für Außen- und Innenbereich mit direktem und gestreutem Lichtstrahl. Streurohr Aus satiniertem opalem PMMA, reflektierende Form aus transparentem PMMA. Befestigung Aus lackiertem Edelstahl oder satiniert.



tavolo table	terra floor	parete_soffitto wall_ceiling	sospensione suspension	esterno outdoor
	p. 77			p. 229
dati tecnici technical data p. 243				



TEDA 302

Lampada da terra per esterno a luce indiretta e diffusa. Tubo diffusore in PMMA opale satinato, barra riflettente in PMMA trasparente. Base in metallo zincato verniciato.

Outside floor lamp giving indirect and diffused light. Satin-finished opal PMMA diffuser tube, transparent PMMA reflecting rod. Zinc-plated painted metal base.

Lampadaire pour l'extérieur à lumière indirecte et diffuse. Tube diffuseur en PMMA opalin satiné, barre réfléchissante en PMMA transparent. Base en métal galvanisé verni.

Stehleuchte für Außenbereiche mit indirektem und diffusem Licht. Streurohr aus satiniertem opalem PMMA, stangenförmiger Reflektor aus Durchsichtigem PMMA. Fuß aus zinkplattiertem und lackiertem Metall.

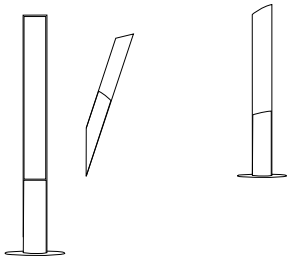

tavolo table	terra floor	parete_soffitto wall_ceiling	sospensione suspension	esterno outdoor
	p. 77	p. 227		
dati tecnici technical data p. 243				

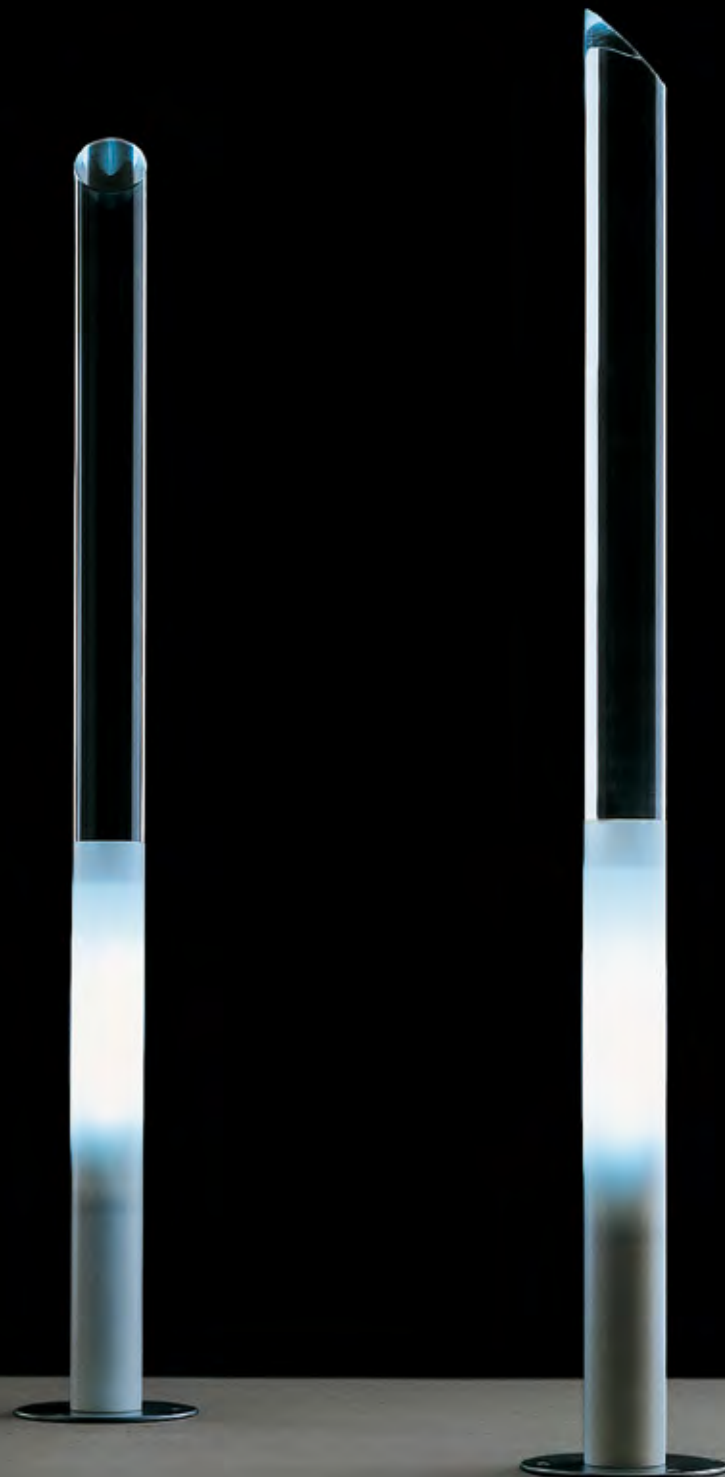





Rosone soffitto / Ceiling rose



LINE 448, 449



FIORE 423,433



P.ZA SAN MARCO 453



**DROP 469
LANTERNA/INA 477, 471
SONORA 438,411
CANOPY 421, 422
CIRCLES 429**



COLOMBO 885, 889



SNOW 492,492 BC



SONORA 490 NE



**SONORA 490 BI/BC,
493 BI/BC**



PIN STRIPE 417



PLATEAU 476, 486



COROA 480



363

Segnalazione Compasso d'Oro
Milano 1955

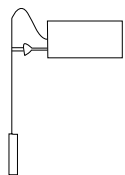

S154

Segnalazione Compasso d'Oro
Milano 1955

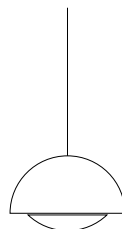

4461

Selezione Compasso d' Oro
Milano 1956

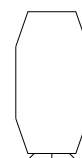

Polivinile

Segnalazione Compasso d'Oro
Milano 1956



COLOMBO 281

Medaglia d'Oro XIII Triennale
Milano 1964
"Philadelphia Museum of Art"
Philadelphia 1983
Museum "Die Neue Sammlung"
München 1983
"Kunstgewerbe Museum"
Zürich 1983
Collezione Permanente del Design Italiano
Triennale di Milano
Museum of Modern Art
New York 1999

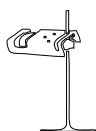

SPIDER 291

Compasso d'Oro ADI
Milano 1967
"Italy: the New Domestic Landscape"
MoMA, New York 1972
"Philadelphia Museum of Art"
Philadelphia 1983
Museum "Die Neue Sammlung"
München 1983



COUPE' 3321

"Museum of Modern Art"
New York 1968
International Design Award
American Institute of Interior Designers
Chicago 1968
Museum "Die Neue Sammlung"
München 1983

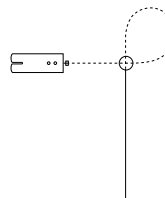

Spring

Segnalazione XIV Triennale
Milano 1968
International Design Award
American Institute of Interior Designers
Chicago 1970
Museum of Modern Art
New York 1970

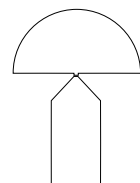

ATOLLO 233

Compasso d'Oro ADI
Milano 1979
"Museum of Modern Art"
New York 1979
"Philadelphia Museum of Art"
Philadelphia 1983
"Kunstgewerbe Museum"
Zürich 1983
Museum "Die Neue Sammlung"
München 1983

"Musuem Fuer Kunst und Gewerbe"
Hamburg 1986
"Kunstmuseum"
Dusseldorf 1989
Collezione Permanente del Design Italiano
Triennale di Milano



NARA 420

Selezione Compasso d'Oro ADI
Milano 1981



SLALOM 299

Museum "Die Neue Sammlung"
München 1983
Selezione Compasso d'Oro ADI 1984
"Museum Fuer Angewandte Kunst"
Köln 1990

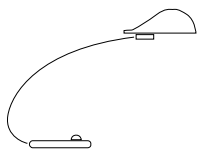

DOGALE 512

Museum "Die Neue Sammlung"
München 1983
"Museum Fuer Angewandte Kunst"
Köln 1990

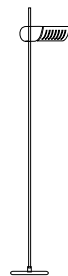

COLOMBO 626

Museum "Die Neue Sammlung"
München 1983
"Kunstmuseum"
Düsseldorf 1989
"Museum Fuer Angewandte Kunst"
Köln 1990



SPIDER 3319

"Italy: the New Domestic Landscape"
MoMA, New York 1972
"Philadelphia Museum of Art"
Philadelphia 1983
"Kunstmuseum"
Düsseldorf 1989
Collezione Permanente del Design Italiano
Triennale di Milano

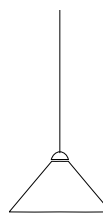

SNOW 401

Museum "Die Neue Sammlung"
München 1983

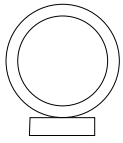

PERLA 241
Museum "Die Neue Sammlung"
 München 1987

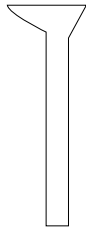

OTELLO 640
"Museum Für Kunst und Gewerbe"
 Hamburg 1986

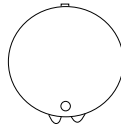

IDOMENEO 121
"Museum Für Kunst und Gewerbe"
 Hamburg 1986

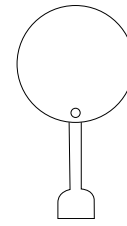

KUTA 250
"Museum Für Kunst und Gewerbe"
 Hamburg 1986

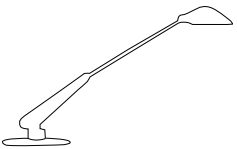

PERSONAL 230
Selezione Compasso d'Oro ADI
 Milano 1989

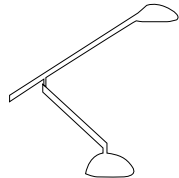

LESTER 220
"Design-Auswahl 1988"
 Stuttgart
"Museum Für Angewandte Kunst"
 Köln 1990



SISTER 365
Selezione Compasso d'Oro ADI
 Milano 1991

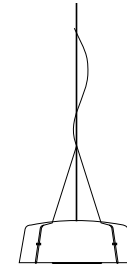

LID
Prix d'excellence Marie Claire Maison
 Parigi 1999
"The state of things" (curated by J.Morrison)
 Berlino, Brunswick 1999, Köln 2000



LULU
"The Wolfsonian/FIU"
 Miami Beach 1999



LANTERNA
"The state of things" (curated by J.Morrison)
 Berlino, Brunswick 1999, Köln 2000
Selezione Compasso d'Oro ADI
 Milano 2001

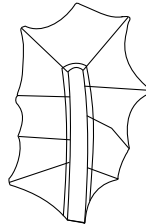

NUVOLA 195
Selezione Compasso d' Oro ADI
 Milano 2001



NUVOLA 196
Selezione Compasso d' Oro ADI
 Milano 2001

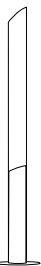

TEDA 302
"Light of the future"
 Frankfurt 2002

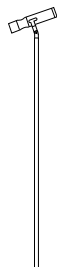

LAMPPU
Selezione Compasso d'Oro ADI
 Milano 2004







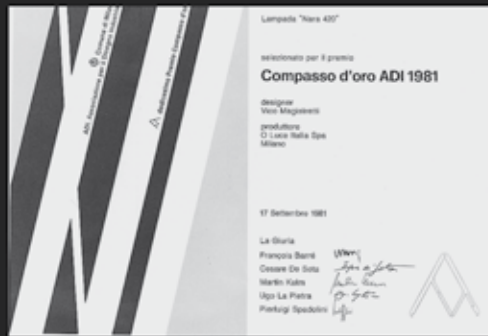
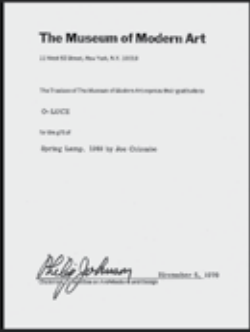







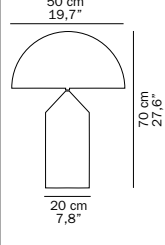





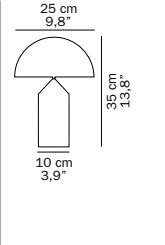

Inoltre o luce ha partecipato, tra le altre, alle seguenti mostre:

X Triennale di Milano
 (medaglia d' oro della Amministrazione Provinciale di Milano)
 Milano 1954
Prima mostra selettiva di Cantù
 1955
Eurodomus
 Genova 1967
Bio 3
 Lubiana 1968
Eurodomus
 Torino 1968
Domus Design
 Zurigo 1969

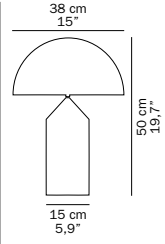
ICSID Congress Exhibition
 Londra 1969
Eurodomus
 Milano 1970
Bio 9 (Atollo)
 Lubiana 1981
Bio 11 (Kalaari)
 Lubiana 1986
"Italia diseño 1946-1986"
 Museo Rufino Tamayo
 (Spider/Colombo/Atollo)
 Città del Messico 1968
Bio 12 (Perla)
 Lubiana 1988



ATOLLO Vico Magistretti

CODICI CODES	DIMENSIONI DIMENSION	TIPOLOGIA TIPOLOGY	STRUTTURA STRUCTURE	COLORE COLOR	DIFFUSORE/RIFLETTORE DIFFUSER/REFLECTOR	COLORE COLOR	SORGENTI BULBS	CERTIFICAZIONI CERTIFICATIONS
233 pagina page 17		• tavolo interno	alluminio	bianco nero	alluminio	bianco nero	2 x max 100W  E27 (dimmer) 	CE  
		• table indoor	aluminium	white black	aluminium	white black		
235 pagina page 19		• tavolo interno	metallo	bianco	vetro soffiato	opale acidato	2 x max 100W  2 x max 25W  E27 (dimmer) 	CE  E14 (dimmer) 
		• table indoor	metal	white	blow glass	opaline opaque		
236 pagina page 19		• tavolo interno	metallo	bianco	vetro soffiato	opale acidato	2 x max 60W  1 x max 25W  E14 	CE  
		• table indoor	metal	white	blow glass	opaline opaque	E14 	
237 pagina page 19		• tavolo interno	metallo	bianco	vetro soffiato	opale acidato	2 x max 75W  1 x max 40W  E27 (dimmer) 	CE  
		• table indoor	metal	white	blow glass	opaline opaque	E14 (dimmer) 	

ATOLLO Vico Magistretti

CODICI CODES	DIMENSIONI DIMENSION	TIPOLOGIA TIPOLOGY	STRUTTURA STRUCTURE	COLORE COLOR	DIFFUSORE/RIFLETTORE DIFFUSER/REFLECTOR	COLORE COLOR	SORGENTI BULBS	CERTIFICAZIONI CERTIFICATIONS
233/OR pagina page 55		• tavolo interno	metallo	oro	metallo	oro	2 x max 100W E27 (dimmer)	CE
		• table indoor	metal	gold	metal	gold		



COLOMBO Joe Colombo

CODICI CODES	DIMENSIONI DIMENSION	TIPOLOGIA TIPOLOGY	STRUTTURA STRUCTURE	COLORE COLOR	DIFFUSORE/RIFLETTORE DIFFUSER/REFLECTOR	COLORE COLOR	SORGENTI BULBS	CERTIFICAZIONI CERTIFICATIONS
281 pagina page 25		• tavolo interno	metallo	nero	PMMA	transparent	1 x max 6W W4,3 x 8,5d	CE
		• table indoor	metal	black	PMMA	transparent		

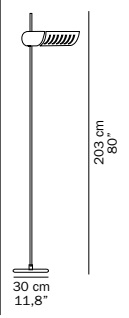

626 pagina page 93		• terra interno	metallo	cromato	alluminio	bianco nero alluminio	1 x max 300W R7s.15 (dimmer)	CE 	<table border="1"> <thead> <tr> <th>H(m)</th> <th colspan="2">Lux</th> </tr> <tr> <th></th> <th>max</th> <th>med</th> </tr> </thead> <tbody> <tr> <td>1.00</td> <td>2229.1</td> <td>933.2</td> </tr> <tr> <td>2.00</td> <td>557.3</td> <td>233.3</td> </tr> <tr> <td>3.00</td> <td>247.7</td> <td>103.7</td> </tr> <tr> <td>4.00</td> <td>139.3</td> <td>58.3</td> </tr> <tr> <td>5.00</td> <td>89.2</td> <td>37.3</td> </tr> </tbody> </table> <table border="1"> <thead> <tr> <th>H(m)</th> <th>1,00</th> <th>2,00</th> <th>3,00</th> <th>4,00</th> <th>5,00</th> </tr> </thead> <tbody> <tr> <td>OA</td> <td>1,50</td> <td>3,00</td> <td>4,50</td> <td>5,90</td> <td>7,40</td> </tr> <tr> <td>OB</td> <td>1,40</td> <td>2,90</td> <td>4,30</td> <td>5,70</td> <td>7,20</td> </tr> <tr> <td>OC</td> <td>0,50</td> <td>1,00</td> <td>1,50</td> <td>2,00</td> <td>2,60</td> </tr> <tr> <td>OD</td> <td>0,50</td> <td>1,00</td> <td>1,50</td> <td>2,00</td> <td>2,60</td> </tr> </tbody> </table>	H(m)	Lux			max	med	1.00	2229.1	933.2	2.00	557.3	233.3	3.00	247.7	103.7	4.00	139.3	58.3	5.00	89.2	37.3	H(m)	1,00	2,00	3,00	4,00	5,00	OA	1,50	3,00	4,50	5,90	7,40	OB	1,40	2,90	4,30	5,70	7,20	OC	0,50	1,00	1,50	2,00	2,60	OD	0,50	1,00	1,50	2,00	2,60
		H(m)	Lux																																																									
	max	med																																																										
1.00	2229.1	933.2																																																										
2.00	557.3	233.3																																																										
3.00	247.7	103.7																																																										
4.00	139.3	58.3																																																										
5.00	89.2	37.3																																																										
H(m)	1,00	2,00	3,00	4,00	5,00																																																							
OA	1,50	3,00	4,50	5,90	7,40																																																							
OB	1,40	2,90	4,30	5,70	7,20																																																							
OC	0,50	1,00	1,50	2,00	2,60																																																							
OD	0,50	1,00	1,50	2,00	2,60																																																							
• floor indoor	metal	chromium plated	aluminium	white black aluminium																																																								

761 pagina page 145		• parete interno	metallo	cromato	alluminio	bianco nero	1 x max 300W R7s.15	CE 	<table border="1"> <thead> <tr> <th>H(m)</th> <th colspan="2">Lux</th> </tr> <tr> <th></th> <th>max</th> <th>med</th> </tr> </thead> <tbody> <tr> <td>1.00</td> <td>2229.1</td> <td>933.2</td> </tr> <tr> <td>2.00</td> <td>557.3</td> <td>233.3</td> </tr> <tr> <td>3.00</td> <td>247.7</td> <td>103.7</td> </tr> <tr> <td>4.00</td> <td>139.3</td> <td>58.3</td> </tr> <tr> <td>5.00</td> <td>89.2</td> <td>37.3</td> </tr> </tbody> </table> <table border="1"> <thead> <tr> <th>H(m)</th> <th>1,00</th> <th>2,00</th> <th>3,00</th> <th>4,00</th> <th>5,00</th> </tr> </thead> <tbody> <tr> <td>OA</td> <td>1,50</td> <td>3,00</td> <td>4,50</td> <td>5,90</td> <td>7,40</td> </tr> <tr> <td>OB</td> <td>1,40</td> <td>2,90</td> <td>4,30</td> <td>5,70</td> <td>7,20</td> </tr> <tr> <td>OC</td> <td>0,50</td> <td>1,00</td> <td>1,50</td> <td>2,00</td> <td>2,60</td> </tr> <tr> <td>OD</td> <td>0,50</td> <td>1,00</td> <td>1,50</td> <td>2,00</td> <td>2,60</td> </tr> </tbody> </table>	H(m)	Lux			max	med	1.00	2229.1	933.2	2.00	557.3	233.3	3.00	247.7	103.7	4.00	139.3	58.3	5.00	89.2	37.3	H(m)	1,00	2,00	3,00	4,00	5,00	OA	1,50	3,00	4,50	5,90	7,40	OB	1,40	2,90	4,30	5,70	7,20	OC	0,50	1,00	1,50	2,00	2,60	OD	0,50	1,00	1,50	2,00	2,60
		H(m)	Lux																																																									
	max	med																																																										
1.00	2229.1	933.2																																																										
2.00	557.3	233.3																																																										
3.00	247.7	103.7																																																										
4.00	139.3	58.3																																																										
5.00	89.2	37.3																																																										
H(m)	1,00	2,00	3,00	4,00	5,00																																																							
OA	1,50	3,00	4,50	5,90	7,40																																																							
OB	1,40	2,90	4,30	5,70	7,20																																																							
OC	0,50	1,00	1,50	2,00	2,60																																																							
OD	0,50	1,00	1,50	2,00	2,60																																																							
• wall indoor	metal	chromium plated	aluminium	white black																																																								

885 pagina page 189		• soffitto interno	metallo	cromato	alluminio	bianco nero	1 x max 300W R7s.15	CE 	<table border="1"> <thead> <tr> <th>H(m)</th> <th colspan="2">Lux</th> </tr> <tr> <th></th> <th>max</th> <th>med</th> </tr> </thead> <tbody> <tr> <td>1.00</td> <td>2229.1</td> <td>933.2</td> </tr> <tr> <td>2.00</td> <td>557.3</td> <td>233.3</td> </tr> <tr> <td>3.00</td> <td>247.7</td> <td>103.7</td> </tr> <tr> <td>4.00</td> <td>139.3</td> <td>58.3</td> </tr> <tr> <td>5.00</td> <td>89.2</td> <td>37.3</td> </tr> </tbody> </table> <table border="1"> <thead> <tr> <th>H(m)</th> <th>1,00</th> <th>2,00</th> <th>3,00</th> <th>4,00</th> <th>5,00</th> </tr> </thead> <tbody> <tr> <td>OA</td> <td>1,50</td> <td>3,00</td> <td>4,50</td> <td>5,90</td> <td>7,40</td> </tr> <tr> <td>OB</td> <td>1,40</td> <td>2,90</td> <td>4,30</td> <td>5,70</td> <td>7,20</td> </tr> <tr> <td>OC</td> <td>0,50</td> <td>1,00</td> <td>1,50</td> <td>2,00</td> <td>2,60</td> </tr> <tr> <td>OD</td> <td>0,50</td> <td>1,00</td> <td>1,50</td> <td>2,00</td> <td>2,60</td> </tr> </tbody> </table>	H(m)	Lux			max	med	1.00	2229.1	933.2	2.00	557.3	233.3	3.00	247.7	103.7	4.00	139.3	58.3	5.00	89.2	37.3	H(m)	1,00	2,00	3,00	4,00	5,00	OA	1,50	3,00	4,50	5,90	7,40	OB	1,40	2,90	4,30	5,70	7,20	OC	0,50	1,00	1,50	2,00	2,60	OD	0,50	1,00	1,50	2,00	2,60
		H(m)	Lux																																																									
	max	med																																																										
1.00	2229.1	933.2																																																										
2.00	557.3	233.3																																																										
3.00	247.7	103.7																																																										
4.00	139.3	58.3																																																										
5.00	89.2	37.3																																																										
H(m)	1,00	2,00	3,00	4,00	5,00																																																							
OA	1,50	3,00	4,50	5,90	7,40																																																							
OB	1,40	2,90	4,30	5,70	7,20																																																							
OC	0,50	1,00	1,50	2,00	2,60																																																							
OD	0,50	1,00	1,50	2,00	2,60																																																							
• suspension indoor	metal	chromium plated	aluminium	white black																																																								

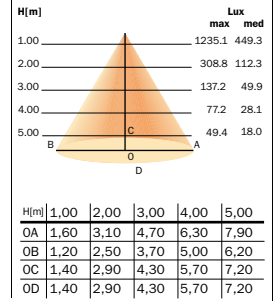
CODICI CODES	DIMENSIONI DIMENSION	TIPOLOGIA TIPOLOGY	STRUTTURA STRUCTURE	COLORE COLOR	DIFFUSORE/RIFLETTORE DIFFUSER/REFLECTOR	COLORE COLOR	SORGENTI BULBS	CERTIFICAZIONI CERTIFICATIONS
669		• terra interno	metallo	cromato	alluminio	bianco nero	2 x max 36W  2 G11 (dimmer)	CE
97		• floor indoor	metal	chromium plated	aluminium	white black		

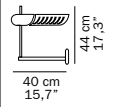



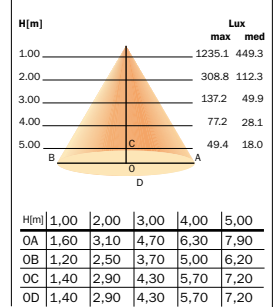

769		• parete interno	metallo	cromato	alluminio	bianco nero	2 x max 36W  2 G11	CE
147		• wall indoor	metal	chromium plated	aluminium	white black		

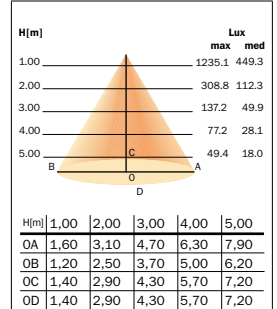

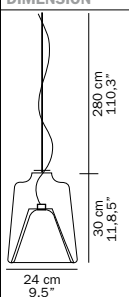

889		• sospensione interno	metallo	cromato	alluminio	bianco nero	2 x max 36W  2 G11	CE
191		• suspension indoor	metal	chromium plated	aluminium	white black		







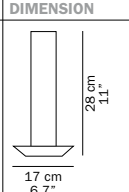

LANTERNA Laudani&Romanelli

CODICI CODES	DIMENSIONI DIMENSION	TIPOLOGIA TIPOLOGY	STRUTTURA STRUCTURE	COLORE COLOR	DIFFUSORE/RIFLETTORE DIFFUSER/REFLECTOR	COLORE COLOR	SORGENTI BULBS	CERTIFICAZIONI CERTIFICATIONS
477		• sospensione interno	alluminio	grigio	vetro	trasparente e sabbato	1 x max 150W  E27	CE  
185		• suspension indoor	aluminium	grey	glass	transparent and sun-blasted		



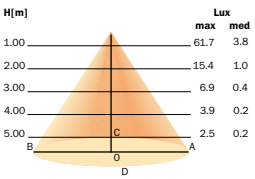

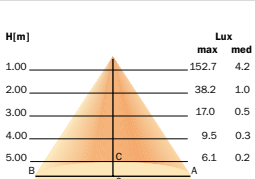
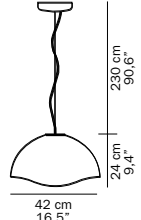
CAND LED Laudani&Romanelli

205		• tavolo interno	alluminio	satinato	PMMA	trasparente	1 x max 1W (LED) 	CE
49		• table indoor	aluminium	satini	PMMA	transparent		

DROP Tito Agnoli

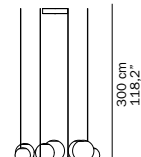
CODICI CODES	DIMENSIONI DIMENSION	TIPOLOGIA TIPOLOGY	STRUTTURA STRUCTURE	COLORE COLOR	DIFFUSORE/RIFLETTORE DIFFUSER/REFLECTOR	COLORE COLOR	SORGENTI BULBS	CERTIFICAZIONI CERTIFICATIONS																														
156		• parete/soffitto interno	metallo	satinato	vetro soffiato	opale acidato	1 x max 40W  G9	CE																														
pagina page																																						
111		• wall/ceiling indoor	metal	satin	blow glass	opaline opaque																																
								 <table border="1"> <thead> <tr> <th>H(m)</th> <th>1,00</th> <th>2,00</th> <th>3,00</th> <th>4,00</th> <th>5,00</th> </tr> </thead> <tbody> <tr> <td>OA</td> <td>5,3</td> <td>10,55</td> <td>15,85</td> <td>21,15</td> <td>26,40</td> </tr> <tr> <td>OB</td> <td>5,3</td> <td>10,55</td> <td>15,85</td> <td>21,15</td> <td>26,40</td> </tr> <tr> <td>OC</td> <td>3,90</td> <td>7,80</td> <td>11,70</td> <td>15,55</td> <td>19,45</td> </tr> <tr> <td>OD</td> <td>3,90</td> <td>7,80</td> <td>11,70</td> <td>15,55</td> <td>19,45</td> </tr> </tbody> </table>	H(m)	1,00	2,00	3,00	4,00	5,00	OA	5,3	10,55	15,85	21,15	26,40	OB	5,3	10,55	15,85	21,15	26,40	OC	3,90	7,80	11,70	15,55	19,45	OD	3,90	7,80	11,70	15,55	19,45
H(m)	1,00	2,00	3,00	4,00	5,00																																	
OA	5,3	10,55	15,85	21,15	26,40																																	
OB	5,3	10,55	15,85	21,15	26,40																																	
OC	3,90	7,80	11,70	15,55	19,45																																	
OD	3,90	7,80	11,70	15,55	19,45																																	
157		• parete/soffitto interno	metallo	satinato	vetro soffiato	opale acidato	1 x max 100W  E27	CE																														
pagina page																																						
111		• wall/ceiling indoor	metal	satin	blow glass	opaline opaque																																
								 <table border="1"> <thead> <tr> <th>H(m)</th> <th>1,00</th> <th>2,00</th> <th>3,00</th> <th>4,00</th> <th>5,00</th> </tr> </thead> <tbody> <tr> <td>OA</td> <td>6,30</td> <td>12,60</td> <td>18,90</td> <td>25,20</td> <td>31,50</td> </tr> <tr> <td>OB</td> <td>6,30</td> <td>12,60</td> <td>18,90</td> <td>25,20</td> <td>31,50</td> </tr> <tr> <td>OC</td> <td>6,30</td> <td>12,60</td> <td>18,90</td> <td>25,20</td> <td>31,50</td> </tr> <tr> <td>OD</td> <td>6,30</td> <td>12,60</td> <td>18,90</td> <td>25,20</td> <td>31,50</td> </tr> </tbody> </table>	H(m)	1,00	2,00	3,00	4,00	5,00	OA	6,30	12,60	18,90	25,20	31,50	OB	6,30	12,60	18,90	25,20	31,50	OC	6,30	12,60	18,90	25,20	31,50	OD	6,30	12,60	18,90	25,20	31,50
H(m)	1,00	2,00	3,00	4,00	5,00																																	
OA	6,30	12,60	18,90	25,20	31,50																																	
OB	6,30	12,60	18,90	25,20	31,50																																	
OC	6,30	12,60	18,90	25,20	31,50																																	
OD	6,30	12,60	18,90	25,20	31,50																																	
469		• sospensione interno	alluminio	satinato	vetro soffiato	opale acidato	1 x max 150W  E27	CE																														
pagina page																																						
175		• suspension indoor	aluminium	satin	blow glass	opaline opaque																																

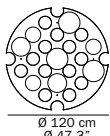
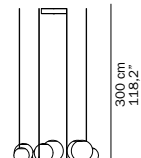
PLATEAU Antonia Astori e Nicola De Ponti

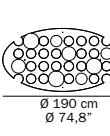
CODICI CODES	DIMENSIONI DIMENSION	TIPOLOGIA TIPOLOGY	STRUTTURA STRUCTURE	COLORE COLOR	DIFFUSORE/RIFLETTORE DIFFUSER/REFLECTOR	COLORE COLOR	SORGENTI BULBS	CERTIFICAZIONI CERTIFICATIONS
476		• sospensione interno	PMMA	trasparente	vetro soffiato	opalino acidato	8 x max 40W  E14	CE
pagina page								
161		• suspension indoor	PMMA	transparent	blow glass	opaline opaque		
486		• sospensione interno	PMMA	trasparente	vetro soffiato	opalino acidato	8 x max 40W  E14	CE
pagina page								
161		• suspension indoor	PMMA	transparent	blow glass	opaline opaque		

LU-LU Stefano Casciani

CODICI CODES	DIMENSIONI DIMENSION	TIPOLOGIA TIPOLOGY	STRUTTURA STRUCTURE	COLORE COLOR	DIFFUSORE/RIFLETTORE DIFFUSER/REFLECTOR	COLORE COLOR	SORGENTI BULBS	CERTIFICAZIONI CERTIFICATIONS
211		• tavolo interno	metallo	satinato	vetro soffiato	opale acidato	1 x max 150W 1 x max 75W E27 (dimmer)	CE
pagina page 37		• table indoor	metal	satin	blow glass	opaline opaque		
311		• terra interno	metallo	cromato	vetro soffiato	opale acidato	1 x max 150W 1 x max 75W E27 (dimmer)	CE
pagina page 75		• floor indoor	metal	chromium plated	blow glass	opaline opaque		

NEROLIA Ferdi Giardini

CODICI CODES	DIMENSIONI DIMENSION	TIPOLOGIA TIPOLOGY	STRUTTURA STRUCTURE	COLORE COLOR	DIFFUSORE/RIFLETTORE DIFFUSER/REFLECTOR	COLORE COLOR	SORGENTI BULBS	CERTIFICAZIONI CERTIFICATIONS
209		• tavolo interno	cristallo soffiato	trasparente	vetro	ambra	1 x max 60W G9 (dimmer)	CE
pagina page 47		• table indoor	blow crystall	transparent	glass	amber		

LUTZ Lutz Pankow



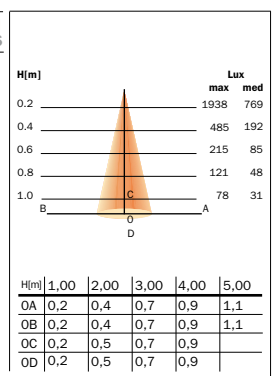

CODICI CODES	DIMENSIONI DIMENSION	TIPOLOGIA TIPOLOGY	STRUTTURA STRUCTURE	COLORE COLOR	DIFFUSORE/RIFLETTORE DIFFUSER/REFLECTOR	COLORE COLOR	SORGENTI BULBS	CERTIFICAZIONI CERTIFICATIONS
290		• tavolo interno	metallo	bianco opaco nero opaco cromato	alluminio	cromato	1 x max 8W(LED)	CE
pagina page 55		• table indoor	metal	opaque white opaque black chromium-plated	aluminium	chromium-plated		

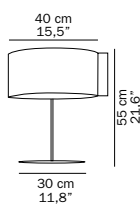

PIN STRIPE Laudani&Romanelli

CODICI CODES	DIMENSIONI DIMENSION	TIPOLOGIA TIPOLOGY	STRUTTURA STRUCTURE	COLORE COLOR	DIFFUSORE/RIFLETTORE DIFFUSER/REFLECTOR	COLORE COLOR	SORGENTI BULBS	CERTIFICAZIONI CERTIFICATIONS
115	 30 cm 11,8"	• parete interno	metallo	bianco	vetro	bianco e nero	2 x max 60W   E27	CE
		• wall indoor	metal	white	glass	white and black		
pagina page	 12 cm 4,7"							
107								
119	 49 cm 19,2"	• parete interno	metallo	bianco	vetro	bianco e nero	2 x max 100W   E27	CE
		• wall indoor	metal	white	glass	white and black		
pagina page	 12 cm 4,7"							
107								
217	 49 cm 19,2"	• tavolo interno	metallo	nero	vetro	bianco e nero	2 x max 100W   E27 (dimmer)	CE 
		• table indoor	metal	black	glass	white and black		
pagina page								
175								
417	 49 cm 19,2"	• sospensione interno	metallo	bianco	vetro	bianco e nero	2 x max 100W   E27	CE
		• suspension indoor	metal	white	glass	white and black		
pagina page								
177								



SWITCH Nendo



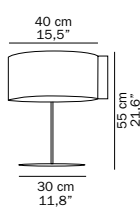

CODICI CODES	DIMENSIONI DIMENSION	TIPOLOGIA TIPOLOGY	STRUTTURA STRUCTURE	COLORE COLOR	DIFFUSORE/RIFLETTORE DIFFUSER/REFLECTOR	COLORE COLOR	SORGENTI BULBS	CERTIFICAZIONI CERTIFICATIONS
206	 40 cm 15,5"	• tavolo interno	metallo	bianco nero oro	metallo	bianco nero oro	2 x max 100W   E27 (dimmer)	CE 
		• table indoor	metal	white black gold	metal	white black gold		
pagina page								
51								

PIN STRIPE Laudani&Romanelli



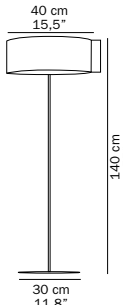

CODICI CODES	DIMENSIONI DIMENSION	TIPOLOGIA TIPOLOGY	STRUTTURA STRUCTURE	COLORE COLOR	DIFFUSORE/RIFLETTORE DIFFUSER/REFLECTOR	COLORE COLOR	SORGENTI BULBS	CERTIFICAZIONI CERTIFICATIONS
115	 30 cm 11.8"	• parete interno	metallo	bianco	vetro	bianco e nero	2 x max 60W ✱ E27	CE
		• wall indoor	metal	white	glass	white and black		
pagina page	 12 cm 4.7"							
107								
119	 49 cm 19.2"	• parete interno	metallo	bianco	vetro	bianco e nero	2 x max 100W ✱ E27	CE
		• wall indoor	metal	white	glass	white and black		
pagina page	 12 cm 4.7"							
107								
217	 49 cm 19.2"	• tavolo interno	metallo	nero	vetro	bianco e nero	2 x max 100W ✱ E27 (dimmer)	CE 
		• table indoor	metal	black	glass	white and black		
pagina page								
175								
417	 49 cm 19.2"	• sospensione interno	metallo	bianco	vetro	bianco e nero	2 x max 100W ✱ E27	CE
		• suspension indoor	metal	white	glass	white and black		
pagina page	 30 cm 11.8"							
177								

SWITCH Nendo

CODICI CODES	DIMENSIONI DIMENSION	TIPOLOGIA TIPOLOGY	STRUTTURA STRUCTURE	COLORE COLOR	DIFFUSORE/RIFLETTORE DIFFUSER/REFLECTOR	COLORE COLOR	SORGENTI BULBS	CERTIFICAZIONI CERTIFICATIONS
206	 40 cm 15.5"	• tavolo interno	metallo	bianco nero oro	metallo	bianco nero oro	2 x max 100W ✱ E27 (dimmer)	CE 
		• table indoor	metal	white black gold	metal	white black gold		
pagina page								
51								

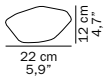
CODICI CODES	DIMENSIONI DIMENSION	TIPOLOGIA TIPOLOGY	STRUTTURA STRUCTURE	COLORE COLOR	DIFFUSORE/RIFLETTORE DIFFUSER/REFLECTOR	COLORE COLOR	SORGENTI BULBS	CERTIFICAZIONI CERTIFICATIONS
306		• terra interno	metallo	bianco nero oro	metallo	bianco nero oro	2 x max 100W   E27 (dimmer)	CE 
pagina page								
83		• floor indoor	metal	white back gold	metal	white back gold		



STONE OF GLASS Laudani&Romanelli

CODICI CODES	DIMENSIONI DIMENSION	TIPOLOGIA TIPOLOGY	STRUTTURA STRUCTURE	COLORE COLOR	DIFFUSORE/RIFLETTORE DIFFUSER/REFLECTOR	COLORE COLOR	SORGENTI BULBS	CERTIFICAZIONI CERTIFICATIONS
202		• tavolo interno	PBT	bianco	vetro soffiato	opale acidato	1 x max 60W   E27 (dimmer)	CE  
pagina page								
43		• table indoor	PPT	white	blow glass	opaline opaque		

203		• tavolo interno	PBT	bianco	vetro soffiato	opale acidato	1 x max 75W   E27 (dimmer)	CE  
pagina page								
43		• table indoor	PBT	white	blow glass	opaline opaque		

204		• tavolo interno	PBT	bianco	vetro soffiato	opale acidato	1 x max 150W   E27 (dimmer)	CE  
pagina page								
43		• table indoor	PBT	white	blow glass	opaline opaque		

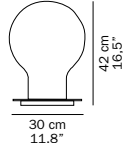
DENQ Toshiyuki Kita

CODICI CODES	DIMENSIONI DIMENSION	TIPOLOGIA TIPOLOGY	STRUTTURA STRUCTURE	COLORE COLOR	DIFFUSORE/RIFLETTORE DIFFUSER/REFLECTOR	COLORE COLOR	SORGENTI BULBS	CERTIFICAZIONI CERTIFICATIONS
229		• tavolo interno	metallo	cromato	vetro soffiato	opale acidato	1 x max 150W   E27 (dimmer)	CE
pagina page								
31		• table indoor	metal	chromium-plated	blow glass	opaline opaque		

DO WITH Carlo Colombo

CODICI CODES	DIMENSIONI DIMENSION	TIPOLOGIA TIPOLOGY	STRUTTURA STRUCTURE	COLORE COLOR	DIFFUSORE/RIFLETTORE DIFFUSER/REFLECTOR	COLORE COLOR	SORGENTI BULBS	CERTIFICAZIONI CERTIFICATIONS
339		• terra interno	alluminio	bianco nero alluminio	alluminio	bianco nero alluminio	1 x max 250W B15d (dimmer)	CE
pagina page 85		• floor indoor	aluminium	white black aluminium	aluminium	white black aluminium		

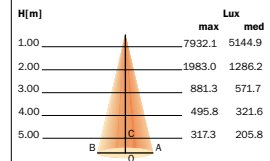

H(m)	1,00	2,00	3,00	4,00	5,00
OA	0,10	0,30	0,40	0,50	0,70
OB	0,20	0,40	0,60	0,80	1,00
OC	0,10	0,30	0,40	0,60	0,70
OD	0,20	0,40	0,60	0,90	1,10

DIM Vico Magistretti

CODICI CODES	DIMENSIONI DIMENSION	TIPOLOGIA TIPOLOGY	STRUTTURA STRUCTURE	COLORE COLOR	DIFFUSORE/RIFLETTORE DIFFUSER/REFLECTOR	COLORE COLOR	SORGENTI BULBS	CERTIFICAZIONI CERTIFICATIONS
333		• terra interno	metallo	chromato	alluminio	bianco nero	1 x max 300W R7s.15 (dimmer)	CE
pagina page 99		• floor indoor	metal	chromium plated	aluminium	white black		

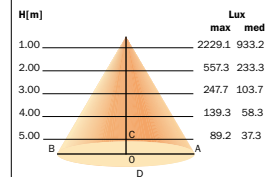

H(m)	1,00	2,00	3,00	4,00	5,00
OA	1,50	3,00	4,50	5,90	7,40
OB	1,40	2,90	4,30	5,70	7,20
OC	0,50	1,00	1,50	2,00	2,60
OD	0,50	1,00	1,50	2,00	2,60



















PASCAL Vico Magistretti

CODICI CODES	DIMENSIONI DIMENSION	TIPOLOGIA TIPOLOGY	STRUTTURA STRUCTURE	COLORE COLOR	DIFFUSORE/RIFLETTORE DIFFUSER/REFLECTOR	COLORE COLOR	SORGENTI BULBS	CERTIFICAZIONI CERTIFICATIONS
345		• terra interno	metallo	bianco	alluminio	bianco	2 x max 100W 1x max 300W R7s.15	CE
pagina page 91		• floor indoor	metal	white	aluminium	white	E27	











SHERWOOD Paolo Imperatori

CODICI CODES	DIMENSIONI DIMENSION	TIPOLOGIA TIPOLOGY	STRUTTURA STRUCTURE	COLORE COLOR	DIFFUSORE/RIFLETTORE DIFFUSER/REFLECTOR	COLORE COLOR	SORGENTI BULBS	CERTIFICAZIONI CERTIFICATIONS
338		• terra interno	metallo	bordeaux	legno/makrofol	mogano	1 x max 205W E27	CE
pagina page 79		• floor indoor	metal	bordeaux	wood/makrofol	mahogany		









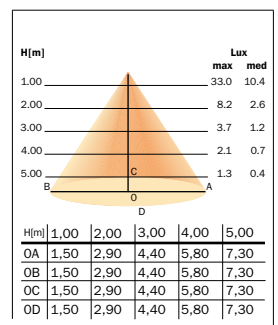
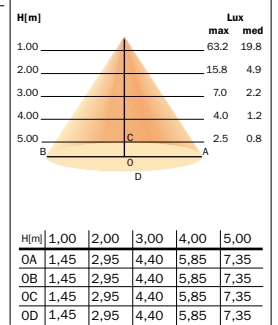

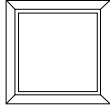

ALIAS Francesco Rota

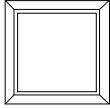
CODICI CODES	DIMENSIONI DIMENSION	TIPOLOGIA TIPOLOGY	STRUTTURA STRUCTURE	COLORE COLOR	DIFFUSORE/RIFLETTORE DIFFUSER/REFLECTOR	COLORE COLOR	SORGENTI BULBS	CERTIFICAZIONI CERTIFICATIONS
124/SP	 15 cm 5,1"	• parete/soffitto interno	metallo	zincato	vetro soffiato e vetro a specchio	opale acidato	1 x max 40W   G9	CE
pagina page 113	 7 cm 2,7"	• wall/ceiling indoor	metal	zinc plated	blow glass and disk mirror	opaline opaque		
178/SP	 28 cm 11"	• parete/soffitto interno	metallo	zincato	vetro soffiato e vetro a specchio	bianco e nero	2 x max 60W   E27 o / or 2 x max 15W   E27	CE 
pagina page 113	 12 cm 4,7"	• wall/ceiling indoor	metal	zinc plated	blow glass and disk mirror	opaline opaque		
198/SP	 35 cm 13,8"	• parete/soffitto interno	metallo	zincato	vetro soffiato e vetro a specchio	bianco e nero	2 x max 75W   E27 o / or 2 x max 20W   E27	CE 
pagina page 113	 14 cm	• wall/ceiling indoor	metal	zinc plated	blow glass and disk mirror	opaline opaque		



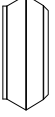
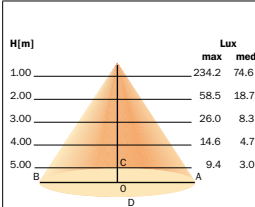
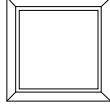



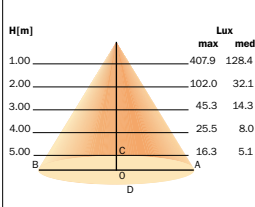

DIAMANTE oluce

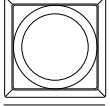
CODICI CODES	DIMENSIONI DIMENSION	TIPOLOGIA TIPOLOGY	STRUTTURA STRUCTURE	COLORE COLOR	DIFFUSORE/RIFLETTORE DIFFUSER/REFLECTOR	COLORE COLOR	SORGENTI BULBS	CERTIFICAZIONI CERTIFICATIONS
182	 13,5 cm 5,3"	• parete/soffitto interno/esterno	acciaio inox	satinato grigio	vetro pyrex	bianco	1 x max 40W   G9	CE  
pagine pages 129 223	 6,5 cm 2,5"	• wall/ceiling indoor/outdoor	stainless steel	satin grey	pyrex glass	white		
182/F	 13,5 cm 5,3"	• parete/soffitto interno/esterno	acciaio inox	satinato grigio	vetro pyrex	bianco	1 x max 9W   GX53	CE 
pagine pages 129 223	 6,5 cm 2,5"	• wall/ceiling indoor/outdoor	stainless steel	satin grey	pyrex glass	white		



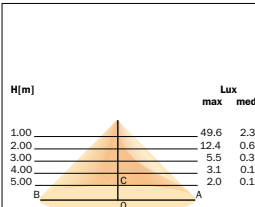
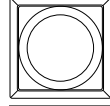

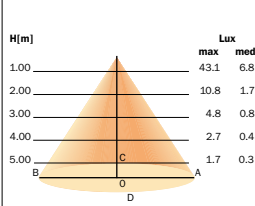

CODICI CODES	DIMENSIONI DIMENSION	TIPOLOGIA TIPOLOGY	STRUTTURA STRUCTURE	COLORE COLOR	DIFFUSORE/RIFLETTORE DIFFUSER/REFLECTOR	COLORE COLOR	SORGENTI BULBS	CERTIFICAZIONI CERTIFICATIONS																														
183	 32 cm 12,6"	•parete/soffitto interno/esterno	acciaio inox	satinato grigio	vetro pyrex	bianco	2 x max 75W   E27	CE  IP65																														
pagine pages																																						
129 223	 10 cm 3,9"	•wall/ceiling indoor/outdoor	stainless steel	satina grey	pyrex glass	white																																
184	 32 cm 12,6"	•parete/soffitto interno/esterno	acciaio inox	satinato grigio	vetro pyrex	bianco	2 x max 26W   G24-q3	CE  IP65																														
pagine pages																																						
129 223	 10 cm 3,9"	•wall/ceiling indoor/outdoor	stainless steel	satina grey	pyrex glass	white		 <table border="1" data-bbox="1446 670 1701 776"> <thead> <tr> <th>H[m]</th> <th>1,00</th> <th>2,00</th> <th>3,00</th> <th>4,00</th> <th>5,00</th> </tr> </thead> <tbody> <tr> <td>OA</td> <td>1,50</td> <td>2,90</td> <td>4,40</td> <td>5,80</td> <td>7,30</td> </tr> <tr> <td>OB</td> <td>1,50</td> <td>2,90</td> <td>4,40</td> <td>5,80</td> <td>7,30</td> </tr> <tr> <td>OC</td> <td>1,40</td> <td>2,80</td> <td>4,30</td> <td>5,70</td> <td>7,10</td> </tr> <tr> <td>OD</td> <td>1,40</td> <td>2,80</td> <td>4,30</td> <td>5,70</td> <td>7,10</td> </tr> </tbody> </table>	H[m]	1,00	2,00	3,00	4,00	5,00	OA	1,50	2,90	4,40	5,80	7,30	OB	1,50	2,90	4,40	5,80	7,30	OC	1,40	2,80	4,30	5,70	7,10	OD	1,40	2,80	4,30	5,70	7,10
H[m]	1,00	2,00	3,00	4,00	5,00																																	
OA	1,50	2,90	4,40	5,80	7,30																																	
OB	1,50	2,90	4,40	5,80	7,30																																	
OC	1,40	2,80	4,30	5,70	7,10																																	
OD	1,40	2,80	4,30	5,70	7,10																																	
185	 32 cm 12,6"	•parete/soffitto interno/esterno	acciaio inox	satinato grigio	vetro pyrex	bianco	1 x max 150W   R7s.15	CE  IP65																														
pagine pages																																						
129 201	 10 cm 3,9"	•wall/ceiling indoor/outdoor	stainless steel	satina grey	pyrex glass	white		 <table border="1" data-bbox="1446 1017 1701 1123"> <thead> <tr> <th>H[m]</th> <th>1,00</th> <th>2,00</th> <th>3,00</th> <th>4,00</th> <th>5,00</th> </tr> </thead> <tbody> <tr> <td>OA</td> <td>1,50</td> <td>2,90</td> <td>4,40</td> <td>5,80</td> <td>7,30</td> </tr> <tr> <td>OB</td> <td>1,50</td> <td>2,90</td> <td>4,40</td> <td>5,80</td> <td>7,30</td> </tr> <tr> <td>OC</td> <td>1,50</td> <td>2,90</td> <td>4,40</td> <td>5,80</td> <td>7,30</td> </tr> <tr> <td>OD</td> <td>1,50</td> <td>2,90</td> <td>4,40</td> <td>5,80</td> <td>7,30</td> </tr> </tbody> </table>	H[m]	1,00	2,00	3,00	4,00	5,00	OA	1,50	2,90	4,40	5,80	7,30	OB	1,50	2,90	4,40	5,80	7,30	OC	1,50	2,90	4,40	5,80	7,30	OD	1,50	2,90	4,40	5,80	7,30
H[m]	1,00	2,00	3,00	4,00	5,00																																	
OA	1,50	2,90	4,40	5,80	7,30																																	
OB	1,50	2,90	4,40	5,80	7,30																																	
OC	1,50	2,90	4,40	5,80	7,30																																	
OD	1,50	2,90	4,40	5,80	7,30																																	

DIAMOND oluce



CODICI CODES	DIMENSIONI DIMENSION	TIPOLOGIA TIPOLOGY	STRUTTURA STRUCTURE	COLORE COLOR	DIFFUSORE/RIFLETTORE DIFFUSER/REFLECTOR	COLORE COLOR	SORGENTI BULBS	CERTIFICAZIONI CERTIFICATIONS																														
181	 13,5 cm 5,3"	•parete/soffitto interno	acciaio inox	lucido	vetro stampato	trasparente sabbaiato	1 x max 40W   G9	CE IP40																														
pagina page																																						
109	 7,5 cm 2,9"	•wall/ceiling indoor	stainless steel	polished	moulded glass	sand blasted transparent		 <table border="1" data-bbox="1446 1419 1701 1525"> <thead> <tr> <th>H[m]</th> <th>1,00</th> <th>2,00</th> <th>3,00</th> <th>4,00</th> <th>5,00</th> </tr> </thead> <tbody> <tr> <td>OA</td> <td>6,55</td> <td>13,10</td> <td>19,65</td> <td>26,20</td> <td>32,75</td> </tr> <tr> <td>OB</td> <td>6,55</td> <td>13,10</td> <td>19,65</td> <td>26,20</td> <td>32,75</td> </tr> <tr> <td>OC</td> <td>6,00</td> <td>12,05</td> <td>18,05</td> <td>24,10</td> <td>30,10</td> </tr> <tr> <td>OD</td> <td>6,00</td> <td>12,05</td> <td>18,05</td> <td>24,10</td> <td>30,10</td> </tr> </tbody> </table>	H[m]	1,00	2,00	3,00	4,00	5,00	OA	6,55	13,10	19,65	26,20	32,75	OB	6,55	13,10	19,65	26,20	32,75	OC	6,00	12,05	18,05	24,10	30,10	OD	6,00	12,05	18,05	24,10	30,10
H[m]	1,00	2,00	3,00	4,00	5,00																																	
OA	6,55	13,10	19,65	26,20	32,75																																	
OB	6,55	13,10	19,65	26,20	32,75																																	
OC	6,00	12,05	18,05	24,10	30,10																																	
OD	6,00	12,05	18,05	24,10	30,10																																	
181/F	 13,5 cm 5,3"	•parete/soffitto interno/esterno	acciaio inox	lucido	vetro stampato	trasparente sabbaiato	1 x max 9W   GX53	CE IP44																														
pagina page																																						
109	 7,5 cm 2,9"	•wall/ceiling indoor/outdoor	stainless steel	polished	moulded glass	sand blasted transparent		 <table border="1" data-bbox="1446 1819 1701 1925"> <thead> <tr> <th>H[m]</th> <th>1,00</th> <th>2,00</th> <th>3,00</th> <th>4,00</th> <th>5,00</th> </tr> </thead> <tbody> <tr> <td>OA</td> <td>2,20</td> <td>4,40</td> <td>6,60</td> <td>8,80</td> <td>11,00</td> </tr> <tr> <td>OB</td> <td>2,20</td> <td>4,50</td> <td>6,70</td> <td>9,0</td> <td>11,20</td> </tr> <tr> <td>OC</td> <td>2,30</td> <td>4,70</td> <td>7,00</td> <td>9,30</td> <td>11,60</td> </tr> <tr> <td>OD</td> <td>2,30</td> <td>4,70</td> <td>7,00</td> <td>9,30</td> <td>11,60</td> </tr> </tbody> </table>	H[m]	1,00	2,00	3,00	4,00	5,00	OA	2,20	4,40	6,60	8,80	11,00	OB	2,20	4,50	6,70	9,0	11,20	OC	2,30	4,70	7,00	9,30	11,60	OD	2,30	4,70	7,00	9,30	11,60
H[m]	1,00	2,00	3,00	4,00	5,00																																	
OA	2,20	4,40	6,60	8,80	11,00																																	
OB	2,20	4,50	6,70	9,0	11,20																																	
OC	2,30	4,70	7,00	9,30	11,60																																	
OD	2,30	4,70	7,00	9,30	11,60																																	

FIORE Laudani&Romanelli

CODICI CODES	DIMENSIONI DIMENSION	TIPOLOGIA TIPOLOGY	STRUTTURA STRUCTURE	COLORE COLOR	DIFFUSORE/RIFLETTORE DIFFUSER/REFLECTOR	COLORE COLOR	SORGENTI BULBS	CERTIFICAZIONI CERTIFICATIONS
103		· parete/soffitto interno	metallo	cromato	vetro soffiato	trasparente	3 x max 40W   E14	CE 
pagina page								
105	13 cm 5.1"	· wall/ceiling indoor	metal	chromium plated	blow glass	transparent		
123		· parete/soffitto interno	metallo	cromato	vetro soffiato	trasparente	3 x max 40W   E14	CE 
pagina page								
105	13 cm 5.1"	· wall/ceiling indoor	metal	chromium plated	blow glass	transparent		
173		· parete/soffitto interno	metallo	cromato	vetro soffiato	trasparente	7 x max 40W   E14	CE 
pagina page								
105	13 cm 5.1"	· wall/ceiling indoor	metal	chromium plated	blow glass	transparent		
423		· sospensione interno	metallo	cromato	vetro soffiato	trasparente	7 x max 40W   E14	CE 
pagina page								
181	46 cm 18.1"	· suspension indoor	metal	chromium plated	blow glass	transparent		
433		· sospensione interno	metallo	cromato	vetro soffiato	trasparente	13 x max 40W   E14	CE 
pagina page								
181	75 cm 29.5"	· suspension indoor	metal	chromium plated	blow glass	transparent		

139		•parete/soffitto interno	metallo	cromato	vetro soffiato	trasparente	1 x max 40W 	CE 
	13,5 cm 5,3"						 E14	
105		•wall/ceiling indoor	metal	chromium plated	blow glass	transparent		
	13 cm 5,1"							

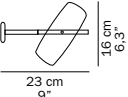

TESSERA Francesco Rota

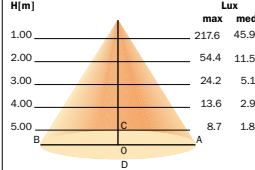
CODICI CODES	DIMENSIONI DIMENSION	TIPOLOGIA TIPOLOGY	STRUTTURA STRUCTURE	COLORE COLOR	DIFFUSORE/RIFLETTORE DIFFUSER/REFLECTOR	COLORE COLOR	SORGENTI BULBS	CERTIFICAZIONI CERTIFICATIONS
113		•parete interno	ottone	cromato	vetro stampato	opale acidato	1 x max 100W  R7s.15	CE IP40 
	23 cm 9"							
133		•wall indoor	brass	chromium plated	moulded glass	opaline opaque		

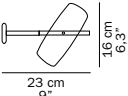

H(m)	Lux max	Lux med
1,00	217,6	45,9
2,00	54,4	11,5
3,00	24,2	5,1
4,00	13,6	2,9
5,00	8,7	1,8

H(m)	1,00	2,00	3,00	4,00	5,00
OA	1,55	3,05	4,60	6,15	7,70
OB	1,55	3,05	4,60	6,15	7,70
OC	2,35	4,75	7,10	9,50	11,85
OD	2,35	4,75	7,10	9,50	11,85

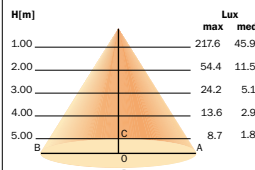

113/SP		•parete interno	ottone	cromato	vetro stampato	opale acidato e dicroicato	1 x max 100W  R7s.15	CE IP40 
	23 cm 9"							
135		•wall indoor	brass	chromium plated	moulded glass	opaline opaque and dichroic finish		



H(m)	Lux max	Lux med
1,00	217,6	45,9
2,00	54,4	11,5
3,00	24,2	5,1
4,00	13,6	2,9
5,00	8,7	1,8

H(m)	1,00	2,00	3,00	4,00	5,00
OA	1,65	3,25	4,90	6,50	8,15
OB	1,65	3,25	4,90	6,50	8,15
OC	2,00	3,95	5,95	7,95	9,90
OD	2,00	3,95	5,95	7,95	9,90



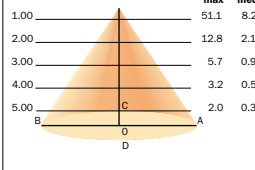

SIXTY oluce

CODICI CODES	DIMENSIONI DIMENSION	TIPOLOGIA TIPOLOGY	STRUTTURA STRUCTURE	COLORE COLOR	DIFFUSORE/RIFLETTORE DIFFUSER/REFLECTOR	COLORE COLOR	SORGENTI BULBS	CERTIFICAZIONI CERTIFICATIONS
107		•parete/soffitto interno	metallo	zincato	vetro soffiato	opale acidato	1 x max 40W  G9	CE
	15 cm 5,9"							
123		•wall/ceiling indoor	metal	zinc plated	blow glass	opaline opaque		



H(m)	Lux max	Lux med
1,00	51,1	8,2
2,00	12,8	2,1
3,00	5,7	0,9
4,00	3,2	0,5
5,00	2,0	0,3



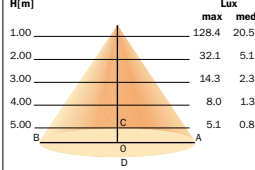

H(m)	1,00	2,00	3,00	4,00	5,00
OA	2,35	4,70	7,05	9,45	11,80
OB	2,35	4,70	7,05	9,45	11,80
OC	2,55	5,10	7,65	10,20	12,75
OD	2,55	5,10	7,65	10,20	12,75

127		•parete/soffitto interno	metallo	zincato	vetro stampato	opale acidato	2 x max 60W  E27	CE 
	27 cm 10,6"						o / or	
123		•wall/ceiling indoor	metal	zinc plated	blow glass	opaline opaque	2 x max 15W  E27	

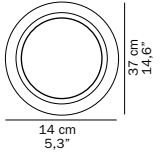

H(m)	Lux max	Lux med
1,00	128,4	20,5
2,00	32,1	5,1
3,00	14,3	2,3
4,00	8,0	1,3
5,00	5,1	0,8

H(m)	1,00	2,00	3,00	4,00	5,00
OA	2,30	4,60	6,90	9,20	11,60
OB	2,30	4,60	6,90	9,20	11,60
OC	2,60	5,20	7,80	10,40	13,00
OD	2,60	5,20	7,80	10,40	13,00

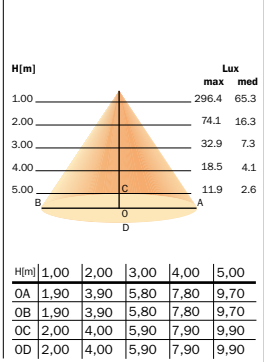

CODICI CODES	DIMENSIONI DIMENSION	TIPOLOGIA TIPOLOGY	STRUTTURA STRUCTURE	COLORE COLOR	DIFFUSORE/RIFLETTORE DIFFUSER/REFLECTOR	COLORE COLOR	SORGENTI BULBS	CERTIFICAZIONI CERTIFICATIONS
137		• parete/soffitto interno	metallo	zincato	vetro stampato	opale acidato	2 x max 75W  E27	CE 
123		• wall/ceiling indoor	metal	zinc plated	blow glass	opaline opaque	o / or 2 x max 20W  E27	



H(m)	1,00	2,00	3,00	4,00	5,00
max	296,4	74,1	32,9	18,5	11,9
med	65,3	16,3	7,3	4,1	2,6

H(m)	1,00	2,00	3,00	4,00	5,00
OA	1,90	3,90	5,80	7,80	9,70
OB	1,90	3,90	5,80	7,80	9,70
OC	2,00	4,00	5,90	7,90	9,90
OD	2,00	4,00	5,90	7,90	9,90

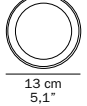

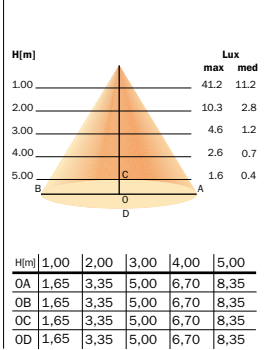

1960 archivio storico Oluce

CODICI CODES	DIMENSIONI DIMENSION	TIPOLOGIA TIPOLOGY	STRUTTURA STRUCTURE	COLORE COLOR	DIFFUSORE/RIFLETTORE DIFFUSER/REFLECTOR	COLORE COLOR	SORGENTI BULBS	CERTIFICAZIONI CERTIFICATIONS
162		• parete/soffitto interno/esterno	alluminio	bianco lucido satinato	vetro stampato	bianco	1 x max 40W  G9	CE 
125 221		• wall/ceiling indoor/outdoor	aluminium	white polished satin	moulded glass	white		

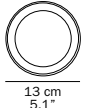

H(m)	1,00	2,00	3,00	4,00	5,00
max	41,2	10,3	4,6	2,6	1,6
med	11,2	2,8	1,2	0,7	0,4



H(m)	1,00	2,00	3,00	4,00	5,00
OA	1,65	3,35	5,00	6,70	8,35
OB	1,65	3,35	5,00	6,70	8,35
OC	1,65	3,35	5,00	6,70	8,35
OD	1,65	3,35	5,00	6,70	8,35

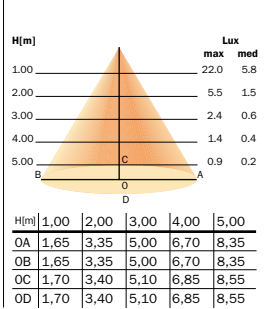



162/F		• parete/soffitto interno/esterno	alluminio	bianco lucido satinato	vetro stampato	bianco	1 x max 9W  GX53	CE 
125 221		• wall/ceiling indoor/outdoor	aluminium	white polished satin	moulded glass	white		

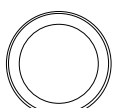

H(m)	1,00	2,00	3,00	4,00	5,00
max	22,0	5,5	2,4	1,4	0,9
med	5,8	1,5	0,6	0,4	0,2

H(m)	1,00	2,00	3,00	4,00	5,00
OA	1,65	3,35	5,00	6,70	8,35
OB	1,65	3,35	5,00	6,70	8,35
OC	1,70	3,40	5,10	6,85	8,55
OD	1,70	3,40	5,10	6,85	8,55



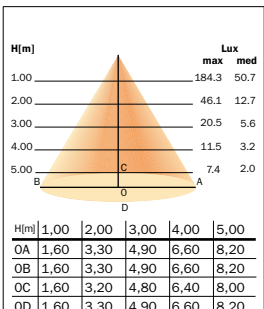

163		• parete/soffitto interno/esterno	alluminio	bianco lucido satinato	vetro stampato	bianco	1 x max 75W  E27	CE 
125 221		• wall/ceiling indoor/outdoor	aluminium	white polished satin	moulded glass	white		

164		• parete/soffitto interno/esterno	alluminio	bianco lucido satinato	vetro stampato	bianco	2 x max 18W  G24-d2	CE 
125 221		• wall/ceiling indoor/outdoor	aluminium	white polished satin	moulded glass	white		

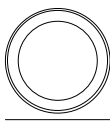

H(m)	1,00	2,00	3,00	4,00	5,00
max	184,3	46,1	20,5	11,5	7,4
med	50,7	12,7	5,6	3,2	2,0





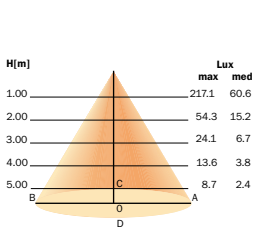

H(m)	1,00	2,00	3,00	4,00	5,00
OA	1,60	3,30	4,90	6,60	8,20
OB	1,60	3,30	4,90	6,60	8,20
OC	1,60	3,20	4,80	6,40	8,00
OD	1,60	3,30	4,90	6,60	8,20

CODICI CODES	DIMENSIONI DIMENSION	TIPOLOGIA TIPOLOGY	STRUTTURA STRUCTURE	COLORE COLOR	DIFFUSORE/RIFLETTORE DIFFUSER/REFLECTOR	COLORE COLOR	SORGENTI BULBS	CERTIFICAZIONI CERTIFICATIONS
165	 27 cm 10,3"	• parete/soffitto interno/esterno	alluminio	bianco lucido satinato	vetro stampato	bianco	1 x max 100W  R7s.15	CE  IP65
113 199	 8 cm 3,1"	• wall/ceiling indoor/outdoor	aluminium	white polished satin	blow glass	white		

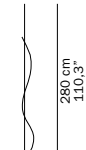



H(m)	1,00	2,00	3,00	4,00	5,00
OA	1,90	3,90	5,80	7,80	9,70
OB	1,90	3,90	5,80	7,80	9,70
OC	2,00	4,00	5,90	7,90	9,90
OD	2,00	4,00	5,90	7,90	9,90



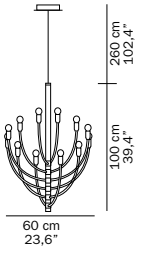

LANTERNINA Laudani&Romanelli

CODICI CODES	DIMENSIONI DIMENSION	TIPOLOGIA TIPOLOGY	STRUTTURA STRUCTURE	COLORE COLOR	DIFFUSORE/RIFLETTORE DIFFUSER/REFLECTOR	COLORE COLOR	SORGENTI BULBS	CERTIFICAZIONI CERTIFICATIONS
471	 280 cm 110,3"	• sospensione interno	alluminio	satinato	vetro	trasparente e sabbato	1 x max 40W   E14	CE  
185	 18,5 cm 7,3" 14 cm 5,5"	• suspension indoor	aluminium	satin	glass	transparent and sun-blasted		

PIAZZA SAN MARCO Vico Magistretti

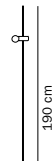
CODICI CODES	DIMENSIONI DIMENSION	TIPOLOGIA TIPOLOGY	STRUTTURA STRUCTURE	COLORE COLOR	DIFFUSORE/RIFLETTORE DIFFUSER/REFLECTOR	COLORE COLOR	SORGENTI BULBS	CERTIFICAZIONI CERTIFICATIONS
453	 260 cm 102,4" 100 cm 39,4" 60 cm 23,6"	• sospensione interno	metallo	cromato	metallo	cromato	12 x max 25W   E14	CE
179		• suspension indoor	metal	chromium plated	metal	chromium plated		

AGNOLI Tito Agnoli



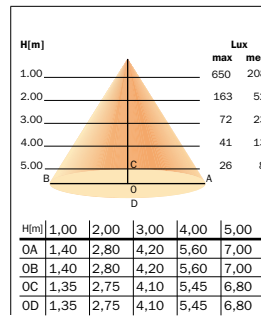

CODICI CODES	DIMENSIONI DIMENSION	TIPOLOGIA TIPOLOGY	STRUTTURA STRUCTURE	COLORE COLOR	DIFFUSORE/RIFLETTORE DIFFUSER/REFLECTOR	COLORE COLOR	SORGENTI BULBS	CERTIFICAZIONI CERTIFICATIONS
387	 190 cm 74,9"	• terra interno	metallo	nickel satinato	metallo	nickel satinato	1 x max 75W   B22	CE
71	 17 cm 6,7"	• floor indoor	metal	satin nickel	metal	satin nickel		

SONORA Vico Magistretti

CODICI CODES	DIMENSIONI DIMENSION	TIPOLOGIA TIPOLOGY	STRUTTURA STRUCTURE	COLORE COLOR	DIFFUSORE/RIFLETTORE DIFFUSER/REFLECTOR	COLORE COLOR	SORGENTI BULBS	CERTIFICAZIONI CERTIFICATIONS
438		• sospensione interno	metallo	bianco	vetro soffiato	opale acidato	1 x max 100W	CE
		• suspension indoor	metal	white	blow glass	opaline opaque	E27	
pagina page								
157								
411		• sospensione interno	metallo	bianco	vetro soffiato	opale acidato	2 x max 100W	CE
		• suspension indoor	metal	white	blow glass	opaline opaque	E27	
pagina page								
157								
490		• sospensione interno	metallo	bianco	PMMA	opale bianco coprente nero	1 x max 150W	CE
		• suspension indoor	metal	white	PMMA	opaline painted white black	E27	
pagina page								
153								
490/OR		• sospensione interno	metallo	bianco	PMMA	interno oro esterno bianco nero	1 x max 150W	CE
		• suspension indoor	metal	white	PMMA	inside gold outside white black	E27	
pagina page								
153								
493		• sospensione interno	metallo	bianco	PMMA	opale bianco coprente	2 x max 150W	CE
		• suspension indoor	metal	white	PMMA	opaline painted white	E27	
pagina page								
153								





FRESNEL Joe Colombo

CODICI CODES	DIMENSIONI DIMENSION	TIPOLOGIA TIPOLOGY	STRUTTURA STRUCTURE	COLORE COLOR	DIFFUSORE/RIFLETTORE DIFFUSER/REFLECTOR	COLORE COLOR	SORGENTI BULBS	CERTIFICAZIONI CERTIFICATIONS
1148		· parete/soffitto interno/esterno	alluminio	bianco nero grigio cromato (solo per interno)	vetro stampato	trasparente sabbiato	1 x max 40W  E14 	CE   IP44
pagine pages 149 211		· wall/ceiling indoor/outdoor	aluminium	white black grey chromium plated (for indoor only)	moulded glass	sun-blasted transparent		

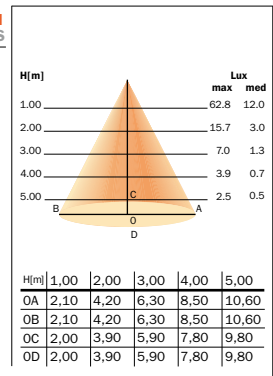
CODICI CODES	DIMENSIONI DIMENSION	TIPOLOGIA TIPOLOGY	STRUTTURA STRUCTURE	COLORE COLOR	DIFFUSORE/RIFLETTORE DIFFUSER/REFLECTOR	COLORE COLOR	SORGENTI BULBS	CERTIFICAZIONI CERTIFICATIONS
1148/F		· parete/soffitto interno/esterno	alluminio	bianco nero grigio	vetro stampato	trasparente sabbiato	1 x max 9W   GX53	CE IP44
pagine pages 149 211		· wall/ceiling indoor/outdoor	aluminium	white black grey	moulded glass	sun-blasted transparent		



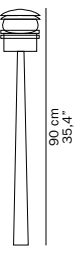

1148/EC		· terra esterno	metallo	nero	vetro stampato	trasparente sabbiato	1 x max 40W  E14 	CE IP45
pagina page 209		· floor outdoor	metal	black	moulded glass	sun-blasted transparent		



1148/EL		· terra esterno	metallo	nero	vetro stampato	trasparente sabbiato	1 x max 40W  E14 	CE IP45
pagina page 209		· floor outdoor	metal	black	moulded glass	sun-blasted transparent		

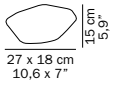

LYNDON Vico Magistretti

CODICI CODES	DIMENSIONI DIMENSION	TIPOLOGIA TIPOLOGY	STRUTTURA STRUCTURE	COLORE COLOR	DIFFUSORE/RIFLETTORE DIFFUSER/REFLECTOR	COLORE COLOR	SORGENTI BULBS	CERTIFICAZIONI CERTIFICATIONS
160 pagina page 207		• parete interno/esterno	metallo	nero	policarbonato	trasparente	1 x max 100W ✱ E27	CE IP23
		• wall indoor/outdoor	metal	black	polycarbonate	transparent		
160/M pagina page 207		• parete interno/esterno	metallo	nero	policarbonato	trasparente	1 x max 100W ✱ E27	CE IP23
		• wall indoor/outdoor	metal	black	polycarbonate	transparent		
350 pagina page 203		• terra esterno	metallo	nero	policarbonato	trasparente	4 x max 100W ✱ E27	CE IP23
		• floor outdoor	metal	black	polycarbonate	transparent		
350/M pagina page 203		• terra esterno	metallo	nero	policarbonato	trasparente	4 x max 100W ✱ E27	CE IP23
		• floor outdoor	metal	black	polycarbonate	transparent		

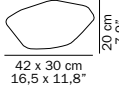

STONES Laudani & Romanelli

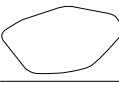
CODICI CODES	DIMENSIONI DIMENSION	TIPOLOGIA TIPOLOGY	STRUTTURA STRUCTURE	COLORE COLOR	DIFFUSORE/RIFLETTORE DIFFUSER/REFLECTOR	COLORE COLOR	SORGENTI BULBS	CERTIFICAZIONI CERTIFICATIONS
207		· terra/tavolo interno/esterno	nylon	bianco	polietilene	bianco	1 x max 12W  ↓ E27	CE  IP65
pagina page								
201		· floor/table indoor/outdoor	nylon	white	polyethylene	white		

208		· terra/tavolo interno/esterno	nylon	bianco	polietilene	bianco	1 x max 25W  ↓ E27	CE  IP65
pagina page								
201		· floor/table indoor/outdoor	nylon	white	polyethylene	white		

CODICI CODES	DIMENSIONI DIMENSION	TIPOLOGIA TIPOLOGY	STRUTTURA STRUCTURE	COLORE COLOR	DIFFUSORE/RIFLETTORE DIFFUSER/REFLECTOR	COLORE COLOR	SORGENTI BULBS	CERTIFICAZIONI CERTIFICATIONS
215		· terra/tavolo interno/esterno	nylon	bianco	polietilene	bianco	1 x max 25W  ↓ E27	CE  IP65
pagina page								
201		· floor/table indoor/outdoor	nylon	white	polyethylene	white		

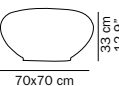





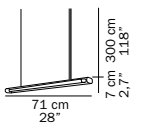

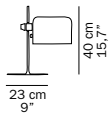

PILL - LOW Francesco Rota

CODICI CODES	DIMENSIONI DIMENSION	TIPOLOGIA TIPOLOGY	STRUTTURA STRUCTURE	COLORE COLOR	DIFFUSORE/RIFLETTORE DIFFUSER/REFLECTOR	COLORE COLOR	SORGENTI BULBS	CERTIFICAZIONI CERTIFICATIONS
219		· terra/tavolo interno/esterno	nylon	bianco	polietilene/tessuto	bianco bianco/azzurro bianco/verde bianco/rosso	1 x max 25W  ↓ E27	CE  IP65
pagina page								
213		· floor/table indoor/outdoor	nylon	white	polyethylene/fabric	white white/light blue white/green white/red		

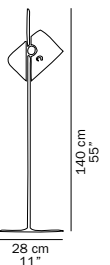

LINE Francesco Rota

CODICI CODES	DIMENSIONI DIMENSION	TIPOLOGIA TIPOLOGY	STRUTTURA STRUCTURE	COLORE COLOR	DIFFUSORE/RIFLETTORE DIFFUSER/REFLECTOR	COLORE COLOR	SORGENTI BULBS	CERTIFICAZIONI CERTIFICATIONS																		
448 pagina page		• sospensione interno	alluminio	lucido	vetro pyrex	trasparente	2 x max 24W 	CE  <table border="1"><thead><tr><th>H(m)</th><th>1,00</th><th>2,00</th><th>3,00</th><th>4,00</th><th>5,00</th></tr></thead><tbody><tr><td>max</td><td>519.0</td><td>129.8</td><td>57.7</td><td>32.4</td><td>20.8</td></tr><tr><td>med</td><td>197.7</td><td>49.4</td><td>22.0</td><td>12.4</td><td>7.9</td></tr></tbody></table>	H(m)	1,00	2,00	3,00	4,00	5,00	max	519.0	129.8	57.7	32.4	20.8	med	197.7	49.4	22.0	12.4	7.9
		H(m)	1,00	2,00	3,00	4,00	5,00																			
max	519.0	129.8	57.7	32.4	20.8																					
med	197.7	49.4	22.0	12.4	7.9																					
193	• suspension indoor	aluminium	polished	pyrex glass	transparent																					
449 pagina page		• sospensione interno	alluminio	lucido	vetro pyrex	trasparente	2 x max 54W 	CE  <table border="1"><thead><tr><th>H(m)</th><th>1,00</th><th>2,00</th><th>3,00</th><th>4,00</th><th>5,00</th></tr></thead><tbody><tr><td>max</td><td>1400.0</td><td>350.0</td><td>155.6</td><td>87.5</td><td>56.0</td></tr><tr><td>med</td><td>554.8</td><td>138.7</td><td>61.6</td><td>34.7</td><td>22.2</td></tr></tbody></table>	H(m)	1,00	2,00	3,00	4,00	5,00	max	1400.0	350.0	155.6	87.5	56.0	med	554.8	138.7	61.6	34.7	22.2
		H(m)	1,00	2,00	3,00	4,00	5,00																			
max	1400.0	350.0	155.6	87.5	56.0																					
med	554.8	138.7	61.6	34.7	22.2																					
193	• suspension indoor	aluminium	polished	pyrex glass	transparent																					
448/C pagina page		• sospensione interno	alluminio	lucido	vetro pyrex/ fibra composita	trasparente	2 x max 24W 	CE  <table border="1"><thead><tr><th>H(m)</th><th>1,00</th><th>2,00</th><th>3,00</th><th>4,00</th><th>5,00</th></tr></thead><tbody><tr><td>max</td><td>519.0</td><td>129.8</td><td>57.7</td><td>32.4</td><td>20.8</td></tr><tr><td>med</td><td>197.7</td><td>49.4</td><td>22.0</td><td>12.4</td><td>7.9</td></tr></tbody></table>	H(m)	1,00	2,00	3,00	4,00	5,00	max	519.0	129.8	57.7	32.4	20.8	med	197.7	49.4	22.0	12.4	7.9
		H(m)	1,00	2,00	3,00	4,00	5,00																			
max	519.0	129.8	57.7	32.4	20.8																					
med	197.7	49.4	22.0	12.4	7.9																					
197	• suspension indoor	aluminium	polished	pyrex glass/ fibre composite	transparent																					
449/C pagina page		• sospensione interno	alluminio	lucido	vetro pyrex/ fibra composita	trasparente	2 x max 54W 	CE  <table border="1"><thead><tr><th>H(m)</th><th>1,00</th><th>2,00</th><th>3,00</th><th>4,00</th><th>5,00</th></tr></thead><tbody><tr><td>max</td><td>1400.0</td><td>350.0</td><td>155.6</td><td>87.5</td><td>56.0</td></tr><tr><td>med</td><td>554.8</td><td>138.7</td><td>61.6</td><td>34.7</td><td>22.2</td></tr></tbody></table>	H(m)	1,00	2,00	3,00	4,00	5,00	max	1400.0	350.0	155.6	87.5	56.0	med	554.8	138.7	61.6	34.7	22.2
		H(m)	1,00	2,00	3,00	4,00	5,00																			
max	1400.0	350.0	155.6	87.5	56.0																					
med	554.8	138.7	61.6	34.7	22.2																					
197	• suspension indoor	aluminium	polished	pyrex glass/ fibre composite	transparent																					
148 pagina page		• parete interno	alluminio	lucido	vetro pyrex	trasparente	2 x max 24W 	CE  <table border="1"><thead><tr><th>H(m)</th><th>1,00</th><th>2,00</th><th>3,00</th><th>4,00</th><th>5,00</th></tr></thead><tbody><tr><td>max</td><td>519.0</td><td>129.8</td><td>57.7</td><td>32.4</td><td>20.8</td></tr><tr><td>med</td><td>197.7</td><td>49.4</td><td>22.0</td><td>12.4</td><td>7.9</td></tr></tbody></table>	H(m)	1,00	2,00	3,00	4,00	5,00	max	519.0	129.8	57.7	32.4	20.8	med	197.7	49.4	22.0	12.4	7.9
		H(m)	1,00	2,00	3,00	4,00	5,00																			
max	519.0	129.8	57.7	32.4	20.8																					
med	197.7	49.4	22.0	12.4	7.9																					
137	• wall indoor	aluminium	polished	pyrex glass	transparent																					



COUPE' Joe Colombo

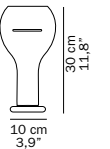

CODICI CODES	DIMENSIONI DIMENSION	TIPOLOGIA TIPOLOGY	STRUTTURA STRUCTURE	COLORE COLOR	DIFFUSORE/RIFLETTORE DIFFUSER/REFLECTOR	COLORE COLOR	SORGENTI BULBS	CERTIFICAZIONI CERTIFICATIONS
2202		• tavolo interno	metallo	cromato	alluminio	bianco nero	1 x max 100W  E27 	CE 
pagina page								
29		• table indoor	metal	chromium plated	aluminium	bianco nero		
3321		• terra interno	metallo	cromato	alluminio	bianco nero	1 x max 100W  E27 	CE 
pagina page								
65		• floor indoor/	metal	chromium plated	aluminium	bianco nero		
3320/R		• terra interno	metallo	cromato	alluminio	bianco nero	1 x max 150W  E27 	CE
pagina page								
61		• floor indoor	metal	chromium plated	aluminium	bianco nero		

FLASH Joe Colombo

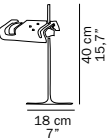

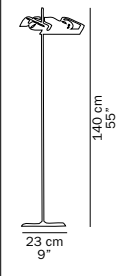

CODICI CODES	DIMENSIONI DIMENSION	TIPOLOGIA TIPOLOGY	STRUTTURA STRUCTURE	COLORE COLOR	DIFFUSORE/RIFLETTORE DIFFUSER/REFLECTOR	COLORE COLOR	SORGENTI BULBS	CERTIFICAZIONI CERTIFICATIONS
2207		• tavolo interno	metallo	nero	alluminio	nero	1 x max 100W  E27 (dimmer) 	CE
pagina page								
27		• table indoor	metal	black	aluminium	nero		





SPIDER Joe Colombo

CODICI CODES	DIMENSIONI DIMENSION	TIPOLOGIA TIPOLOGY	STRUTTURA STRUCTURE	COLORE COLOR	DIFFUSORE/RIFLETTORE DIFFUSER/REFLECTOR	COLORE COLOR	SORGENTI BULBS	CERTIFICAZIONI CERTIFICATIONS
291		• tavolo interno	metallo	cromato	alluminio	bianco nero	1 x max 75W  B22 	CE
pagina page								
23		• table indoor	metal	chromium plated	aluminium	white black		

CODICI CODES	DIMENSIONI DIMENSION	TIPOLOGIA TIPOLOGY	STRUTTURA STRUCTURE	COLORE COLOR	DIFFUSORE/RIFLETTORE DIFFUSER/REFLECTOR	COLORE COLOR	SORGENTI BULBS	CERTIFICAZIONI CERTIFICATIONS
3319		• terra interno	metallo	cromato	alluminio	bianco nero	1 x max 75W   B22	CE
pagina page 69		• floor indoor	metal	chromium plated	aluminium	white black		

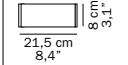
UNIVERSAL Laudani&Romanelli





CODICI CODES	DIMENSIONI DIMENSION	TIPOLOGIA TIPOLOGY	STRUTTURA STRUCTURE	COLORE COLOR	DIFFUSORE/RIFLETTORE DIFFUSER/REFLECTOR	COLORE COLOR	SORGENTI BULBS	CERTIFICAZIONI CERTIFICATIONS
129		• parete interno	alluminio	cromato	vetro	nero stop sol	1 x max 40W   G9	CE
pagina page 143		• wall indoor	aluminium	chromium plated	glass	black stop sol		

106		• parete interno	alluminio	cromato	vetro	nero stop sol	1 x max 100W   R7s.15	CE
pagina page 143		• wall indoor	aluminium	chromium plated	glass	black stop sol		

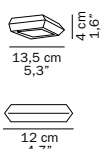

108		• parete interno	alluminio	cromato	vetro soffiato	nero stop sol	2 x max 24W   G5	CE
pagina page 139		• wall indoor	aluminium	chromium plated	blow glass	black stop sol		

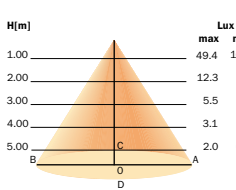
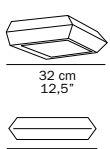
109		• parete interno	alluminio	cromato	vetro soffiato	nero stop sol	2 x max 39W   G5	CE
pagina page 139		• wall indoor	aluminium	chromium plated	blow glass	black stop sol		

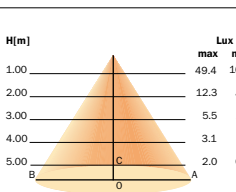

DIAMANTE/O oluce

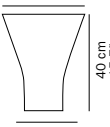
CODICI CODES	DIMENSIONI DIMENSION	TIPOLOGIA TIPOLOGY	STRUTTURA STRUCTURE	COLORE COLOR	DIFFUSORE/RIFLETTORE DIFFUSER/REFLECTOR	COLORE COLOR	SORGENTI BULBS	CERTIFICAZIONI CERTIFICATIONS																														
191 pagine pages 131 225		• parete/soffitto interno/esterno	acciaio inox	satinato grigio	vetro pyrex	bianco	1 x max 60W  G9	CE IP43  <table border="1"> <thead> <tr> <th>H(m)</th> <th>1,00</th> <th>2,00</th> <th>3,00</th> <th>4,00</th> <th>5,00</th> </tr> </thead> <tbody> <tr> <td>OA</td> <td>1,40</td> <td>2,75</td> <td>4,15</td> <td>5,55</td> <td>6,90</td> </tr> <tr> <td>OB</td> <td>1,40</td> <td>2,75</td> <td>4,15</td> <td>5,55</td> <td>6,90</td> </tr> <tr> <td>OC</td> <td>1,35</td> <td>2,75</td> <td>4,10</td> <td>5,45</td> <td>6,85</td> </tr> <tr> <td>OD</td> <td>1,35</td> <td>2,75</td> <td>4,10</td> <td>5,45</td> <td>6,85</td> </tr> </tbody> </table>	H(m)	1,00	2,00	3,00	4,00	5,00	OA	1,40	2,75	4,15	5,55	6,90	OB	1,40	2,75	4,15	5,55	6,90	OC	1,35	2,75	4,10	5,45	6,85	OD	1,35	2,75	4,10	5,45	6,85
		H(m)	1,00	2,00	3,00	4,00	5,00																															
OA	1,40	2,75	4,15	5,55	6,90																																	
OB	1,40	2,75	4,15	5,55	6,90																																	
OC	1,35	2,75	4,10	5,45	6,85																																	
OD	1,35	2,75	4,10	5,45	6,85																																	
• wall/ceiling indoor/outdoor	stainless steel	satin grey	pyrex glass	white																																		
192 pagine pages 131 225		• parete/soffitto interno/esterno	acciaio inox	satinato grigio	vetro pyrex	bianco	2 x max 26W  G24-q3	CE IP43  <table border="1"> <thead> <tr> <th>H(m)</th> <th>1,00</th> <th>2,00</th> <th>3,00</th> <th>4,00</th> <th>5,00</th> </tr> </thead> <tbody> <tr> <td>OA</td> <td>1,50</td> <td>2,90</td> <td>4,40</td> <td>5,80</td> <td>7,30</td> </tr> <tr> <td>OB</td> <td>1,50</td> <td>2,90</td> <td>4,40</td> <td>5,80</td> <td>7,30</td> </tr> <tr> <td>OC</td> <td>1,50</td> <td>3,00</td> <td>4,40</td> <td>5,90</td> <td>7,40</td> </tr> <tr> <td>OD</td> <td>1,50</td> <td>3,00</td> <td>4,40</td> <td>5,90</td> <td>7,40</td> </tr> </tbody> </table>	H(m)	1,00	2,00	3,00	4,00	5,00	OA	1,50	2,90	4,40	5,80	7,30	OB	1,50	2,90	4,40	5,80	7,30	OC	1,50	3,00	4,40	5,90	7,40	OD	1,50	3,00	4,40	5,90	7,40
		H(m)	1,00	2,00	3,00	4,00	5,00																															
OA	1,50	2,90	4,40	5,80	7,30																																	
OB	1,50	2,90	4,40	5,80	7,30																																	
OC	1,50	3,00	4,40	5,90	7,40																																	
OD	1,50	3,00	4,40	5,90	7,40																																	
• wall/ceiling indoor/outdoor	stainless steel	satin grey	pyrex glass	white																																		





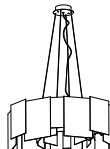





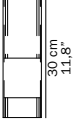

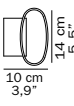

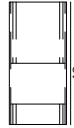

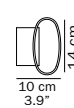
AREZZO Gordon Guillaumier

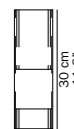
CODICI CODES	DIMENSIONI DIMENSION	TIPOLOGIA TIPOLOGY	STRUTTURA STRUCTURE	COLORE COLOR	DIFFUSORE/RIFLETTORE DIFFUSER/REFLECTOR	COLORE COLOR	SORGENTI BULBS	CERTIFICAZIONI CERTIFICATIONS
227 pagina page 33		• tavolo interno	metallo	bianco	vetro soffiato	opale lucido	1 x max 150W  E27 (dimmer)	CE
		• table indoor	metal	white	blow glass	glossy opaline		

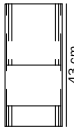

COROA Emmanuel Babled

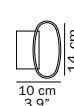
CODICI CODES	DIMENSIONI DIMENSION	TIPOLOGIA TIPOLOGY	STRUTTURA STRUCTURE	COLORE COLOR	DIFFUSORE/RIFLETTORE DIFFUSER/REFLECTOR	COLORE COLOR	SORGENTI BULBS	CERTIFICAZIONI CERTIFICATIONS
480 pagina page 165		• sospensione interno	metallo	bianco	PMMA	bianco opaco bispecchio	16 x max 25W  E14	CE
		• suspension indoor	metal	white	PMMA	opaque white double-face mirror		

LINE Francesco Rota



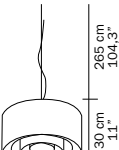

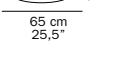
CODICI CODES	DIMENSIONI DIMENSION	TIPOLOGIA TIPOLOGY	STRUTTURA STRUCTURE	COLORE COLOR	DIFFUSORE/RIFLETTORE DIFFUSER/REFLECTOR	COLORE COLOR	SORGENTI BULBS	CERTIFICAZIONI CERTIFICATIONS
147		• parete interno	alluminio	cromato	vetro pirex	trasparente	2 x max 40W  2 G9	CE
pagina page						o/or		
115		• wall indoor	aluminium	chromium plated	pirex glass	transparent	2 x max 7W  fluo 2 G9	
149		• parete interno	alluminio	cromato	vetro pirex trasparente	trasparente	2 x max 40W  2 G9	CE
pagina page						o/or		
115		• wall indoor	aluminium	chromium plated	pirex glass	transparent	2 x max 7W  fluo 2 G9	
147/C		• parete interno	alluminio	cromato	vetro pirex / fibra composita	trasparente	2 x max 40W  2 G9	CE
pagina page						o/or		
117		• wall indoor	aluminium	chromium plated	pirex glass/ fibre composite	transparent	2 x max 7W  fluo 2 G9	
149/C		• parete interno	alluminio	cromato	vetro pirex / fibra composita	trasparente	2 x max 40W  2 G9	CE
pagina page						o/or		
117		• wall indoor	aluminium	chromium plated	pirex glass/ fibre composite	transparent	2 x max 7W  fluo 2 G9	

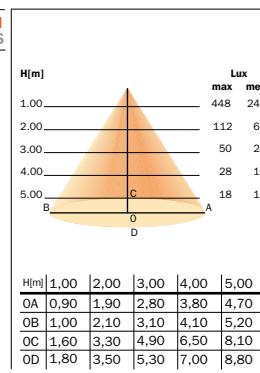
CIRCLES Laudani & Romanelli



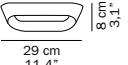

CODICI CODES	DIMENSIONI DIMENSION	TIPOLOGIA TIPOLOGY	STRUTTURA STRUCTURE	COLORE COLOR	DIFFUSORE/RIFLETTORE DIFFUSER/REFLECTOR	COLORE COLOR	SORGENTI BULBS	CERTIFICAZIONI CERTIFICATIONS
429		• sospensione interno	metallo	bianco	tessuto	bianco esterno argento interno	4 x max 20W  E27	CE
pagina page						marrone esterno oro interno		
167		• suspension indoor	metal	white	fabric	white outside silver inside		
						brown outside gold inside		

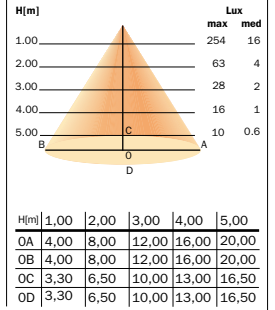

JK Francesco Rota

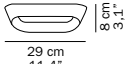

CODICI CODES	DIMENSIONI DIMENSION	TIPOLOGIA TIPOLOGY	STRUTTURA STRUCTURE	COLORE COLOR	DIFFUSORE/RIFLETTORE DIFFUSER/REFLECTOR	COLORE COLOR	SORGENTI BULBS	CERTIFICAZIONI CERTIFICATIONS
780/BI	 29 cm 11,4" 8 cm 3,1"	• parete interno	metallo	bianco opaco	alluminio	bianco opaco	1 x max 160W  R7s.15	CE 
pagina page								
119	 14 cm 5,5"	• wall indoor	metal	white mat	aluminium	white mat		



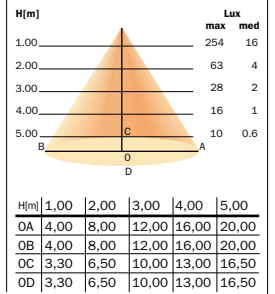

780/BV	 29 cm 11,4" 8 cm 3,1"	• parete interno	metallo	bianco opaco	alluminio	interno verde chiaro esterno bianco opaco	1 x max 160W  R7s.15	CE 
pagina page								
119	 14 cm 5,5"	• wall indoor	metal	white mat	aluminium	inside light green outside white mat		

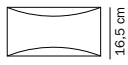



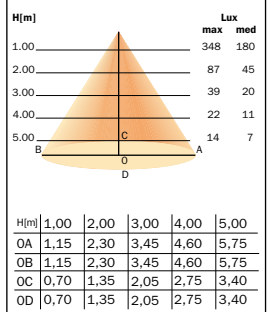

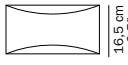
KELLY Studio 63

CODICI CODES	DIMENSIONI DIMENSION	TIPOLOGIA TIPOLOGY	STRUTTURA STRUCTURE	COLORE COLOR	DIFFUSORE/RIFLETTORE DIFFUSER/REFLECTOR	COLORE COLOR	SORGENTI BULBS	CERTIFICAZIONI CERTIFICATIONS
790	 32,5 cm 12,8" 16,5 cm 6,5"	• parete interno	metallo	bianco	metallo	bianco cromato	1 x max 120W  R7s.15	CE
pagina page								
121	 6 cm 2,36"	• wall indoor	metal	white	metal	white chromium-plated		

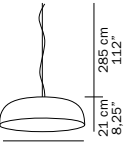

791	 32,5 cm 12,8" 16,5 cm 6,5"	• parete interno	metallo	bianco	metallo	bianco cromato	max 8W LED 	CE
pagina page								
121	 6 cm 2,36"	• wall indoor	metal	white	metal	white chromium-plated		

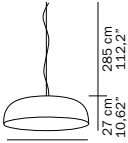
CANOPY Francesco Rota

CODICI CODES	DIMENSIONI DIMENSION	TIPOLOGIA TIPOLOGY	STRUTTURA STRUCTURE	COLORE COLOR	DIFFUSORE/RIFLETTORE DIFFUSER/REFLECTOR	COLORE COLOR	SORGENTI BULBS	CERTIFICAZIONI CERTIFICATIONS
421 pagina page 171		•sospensione interno	PMMA	bianco	PMMA	bianco/bianco bianco/fucsia bianco/melone	1 x max 55W  ○ 2GX13	CE 
		•suspension indoor	PMMA	white	PMMA	white/white white/fuchsia white/melon		
422 pagina page 171		•sospensione interno	metallo	bianco	alluminio	bianco/bianco bianco/fucsia bianco/melone	1 x max 55W  ○ 2GX13	CE 
		•suspension indoor	metal	white	aluminium	white/white white/fuchsia white/melon		

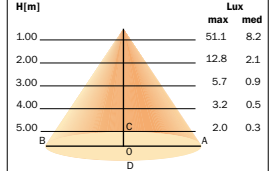

H(m)	1,00	2,00	3,00	4,00	5,00
OA	2,35	4,70	7,05	9,45	11,80
OB	2,35	4,70	7,05	9,45	11,80
OC	2,55	5,10	7,65	10,20	12,75
OD	2,55	5,10	7,65	10,20	12,75

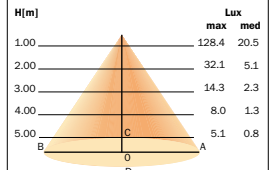





H(m)	1,00	2,00	3,00	4,00	5,00
OA	2,30	4,60	6,90	9,20	11,60
OB	2,30	4,60	6,90	9,20	11,60
OC	2,60	5,20	7,80	10,40	13,00
OD	2,60	5,20	7,80	10,40	13,00

BETH Carlo Colombo

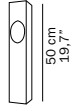
CODICI CODES	DIMENSIONI DIMENSION	TIPOLOGIA TIPOLOGY	STRUTTURA STRUCTURE	COLORE COLOR	DIFFUSORE/RIFLETTORE DIFFUSER/REFLECTOR	COLORE COLOR	SORGENTI BULBS	CERTIFICAZIONI CERTIFICATIONS
249 pagina page 89		•tavolo interno	metallo	bianco	alluminio	bianco	2 x max 24W  ⌚ E27	CE
		•table indoor	metal	white	aluminium	white		
349 pagina page 89		•terra interno	metallo	bianco	alluminio	bianco	2 x max 30W  ⌚ E27	CE
		•floor indoor	metal	white	aluminium	white		

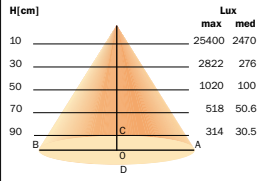
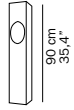
ELA Lutz Pankow

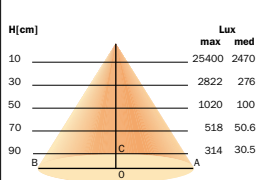





















CODICI CODES	DIMENSIONI DIMENSION	TIPOLOGIA TIPOLOGY	STRUTTURA STRUCTURE	COLORE COLOR	DIFFUSORE/RIFLETTORE DIFFUSER/REFLECTOR	COLORE COLOR	SORGENTI BULBS	CERTIFICAZIONI CERTIFICATIONS																															
308 pagina page 217	 9x9 cm 3,5x3,5"	•terra esterno	metallo	zincato	legno Accoya	legno naturale	1 x max 8W LED 	CE IP65	 <table border="1"> <thead> <tr> <th>H[cm]</th> <th>10,0</th> <th>30,0</th> <th>50,0</th> <th>70,0</th> <th>90,0</th> </tr> </thead> <tbody> <tr> <td>OA</td> <td>10,0</td> <td>30</td> <td>50</td> <td>70</td> <td>90</td> </tr> <tr> <td>OB</td> <td>9,5</td> <td>29</td> <td>47,5</td> <td>67</td> <td>85,5</td> </tr> <tr> <td>OC</td> <td>25,5</td> <td>77</td> <td>127</td> <td>180</td> <td>230</td> </tr> <tr> <td>OD</td> <td>5,5</td> <td>17</td> <td>27,5</td> <td>39</td> <td>49,5</td> </tr> </tbody> </table>	H[cm]	10,0	30,0	50,0	70,0	90,0	OA	10,0	30	50	70	90	OB	9,5	29	47,5	67	85,5	OC	25,5	77	127	180	230	OD	5,5	17	27,5	39	49,5
		H[cm]	10,0	30,0	50,0	70,0				90,0																													
OA	10,0	30	50	70	90																																		
OB	9,5	29	47,5	67	85,5																																		
OC	25,5	77	127	180	230																																		
OD	5,5	17	27,5	39	49,5																																		
•floor outdoor	metal	zinc-plated	Accoya wood	natural wood																																			
318 pagina page 217	 9x9 cm 3,5x3,5"	•terra esterno	metallo	zincato	legno Accoya	legno naturale	1 x max 8W LED 	CE IP65	 <table border="1"> <thead> <tr> <th>H[cm]</th> <th>10,0</th> <th>30,0</th> <th>50,0</th> <th>70,0</th> <th>90,0</th> </tr> </thead> <tbody> <tr> <td>OA</td> <td>10,0</td> <td>30</td> <td>50</td> <td>70</td> <td>90</td> </tr> <tr> <td>OB</td> <td>9,5</td> <td>29</td> <td>47,5</td> <td>67</td> <td>85,5</td> </tr> <tr> <td>OC</td> <td>25,5</td> <td>77</td> <td>127</td> <td>180</td> <td>230</td> </tr> <tr> <td>OD</td> <td>5,5</td> <td>17</td> <td>27,5</td> <td>39</td> <td>49,5</td> </tr> </tbody> </table>	H[cm]	10,0	30,0	50,0	70,0	90,0	OA	10,0	30	50	70	90	OB	9,5	29	47,5	67	85,5	OC	25,5	77	127	180	230	OD	5,5	17	27,5	39	49,5
		H[cm]	10,0	30,0	50,0	70,0				90,0																													
OA	10,0	30	50	70	90																																		
OB	9,5	29	47,5	67	85,5																																		
OC	25,5	77	127	180	230																																		
OD	5,5	17	27,5	39	49,5																																		
•floor outdoor	metal	zinc-plated	Accoya wood	natural wood																																			

O-Luce si riserva la facoltà di modificare, in qualunque momento e senza preavviso, le caratteristiche tecniche degli elementi illustrati nel presente catalogo.

O-Luce reserves the right to change, at any time and without prior warning, the technical specification of any product illustrated in this catalogue.

O-Luce behaelt sich vor, jederzeit und ohne Ankuendigung, technische Veraenderungen an den in dieser katalog gezeigten Modellen vorzunehmen.

O-Luce se réserve le droit de modifier, à n'import quel moment et sans préavis, les caractéristiques techniques des éléments illustrés dans ce catalogue

	E14	Trasparente Clear, Glasklar, Claire		Lampada conforme alle norme di sicurezza CEI, approvata dall'Istituto Italiano del Marchio di Qualità (I.M.Q.).
	E27	Trasparente Clear, Glasklar, Claire		Lamp in compliance with IEC safety standards and approved by the Istituto Italiano del Marchio di Qualità (I.M.Q.).
	E27	Opalina Opaline, Opalen, Opaline		Leuchte gemaess IEC Sicherheitsnormen hergestellt sowie vom Istituto Italiano del Marchio di Qualità (I.M.Q.) zugelassen.
	E27	Sferica opalina Spherical opaline Kugelfoermig opalen Sphérique opaline		Lampe conforme aux normes de sécurité IEC, et agréée par L'Istituto Italiano del Marchio di Qualità (I.M.Q.).
	E27	Globolux		
	E27	Fluorescente Fluorescent Fluoreszierend Fluo SL.		Marchio americano di certificazione Underwriters Laboratories Inc. Marque américain de certification Zertifikat für amerikanisches Warenzeichen
	G5	Tubo fluorescente Fluorescent bulb Leuchtstofflampe Tube fluorescent	CE	Marchio Comunità Europea European Community Mark Marque Communauté Européenne Warenzeichen der Europäischen Gemeinschaft
	G24	Fluorescente Fluorescent Fluoreszierend Fluo 26W.	IP 23	Apparecchio protetto contro la pioggia. Rainproof lamp. Geraet regengeschuetzt. Appareil protégé contre la pluie.
	G24	Fluorescente Fluorescent Fluoreszierend Fluo 13/18 W.	IP44	Apparecchio protetto contro gli spruzzi d'acqua. Water spray proof lamp. Geraet spritzwassegeschuetzt. Appareil protégé contre l'aspersion d'eau.
	E14 E27	Incandescente Incandescent Incandescent Glühend	IP45 IP55 IP65	Apparecchio protetto contro i getti d'acqua. Water jet proof lamp. Geraet wasserstrahlggeschuetzt. Appareil protégé contre les jets d'eau.
	G9	Alogena Halogen, Halogen, Halogène		Classe II Classe II Schutzklasse II Classe II
	Gy6.35	Alogena Halogen, Halogen, Halogène		
	R7s.15	Alogena Tubulare Halogen tubular Halogen Roehrenfoermige Halogène tubulaire		
	E27	Alogena Halogen, Halogen, Halogène		
	E14	Alogena Halogen, Halogen, Halogène		
	GX53	Fluorescente Fluorescent Fluoreszierend Fluo		
	B22	Incandescente Incandescent Incandescent Glühend		
	B15d	Alogena Halogen, Halogen, Halogène		
		Circolina Circolin, Circolin, Circolin		

Un sentito ringraziamento per la squisita ospitalità va a:

Alessandra Alabiso
Michela Darini
Alex Esposito
Laura Ghioni
Antonella Marchetti
Patrizia e Marcello Pelizzeni
Patrizia Rabaglia
Pierluigi Scalamoia
Simona Silenzi
Tiziana Spada
Andrea Tenerani

e inoltre a:

Advent International
B&S Electra spa
Cogesta spa
Driade
è De Padova
Knoll International
Residence "I Ronchi"
Siloe

La casa fotografata a pagina 20-21-36-38-39-74-128
è stata progettata dall'architetto Umberto Zanetti

La casa fotografata a pagina 30-48-70-196
è stata progettata dall'architetto Marco Savorelli

La casa fotografata a pagina 66-67-68-86-87
è stata progettata da Francesco Rota

La casa fotografata a pagina 26-64-134
è stata progettata dall'architetto Raffaele Cassina

La casa fotografata a pagina 28-84-110
è stata progettata dall'architetto Ruggero Rickler del Mare

La casa fotografata a pagina 32-34-35-78-80-81-118-124-158-159-174
è stata progettata dall'architetto Marco Romanelli

La casa fotografata a pagina 50-52-53-72-82-176-180-182-183
è stata progettata dagli architetti Beatrice e Axel Castiglione

La casa fotografata a pagina 156-184-186-187-210-220
è stata progettata dall'architetto Emilio Tirelli

Gli uffici fotografati a pagina 88
sono stati progettati dall'architetto Carlo Colombo

Gli uffici fotografati a pagina 90-144
sono stati progettati dall'architetto Vico Magistretti

Gli uffici fotografati a pagina 94-95-98-100-101
sono stati progettati dall'architetto Umberto Zanetti

Gli uffici fotografati a pagina 178-190-192
sono stati progettati da Francesco Rota

ulteriori crediti fotografici:

la foto alla pagina 19 è di Tiziano Sartorio

le foto alle pagine 25-91-93-99-149-203-207
sono di Studio Azzurro

le foto alle pagine 23-27-29-65-69
sono di Donato Di Bello

Finito di stampare presso Arti Grafiche Mario Bazzi Spa nel giugno 2011